

ARO[®]

EXPERT SERIES AIR OPERATED DIAPHRAGM PUMPS

1/4" THROUGH 3" FLUID PORTS

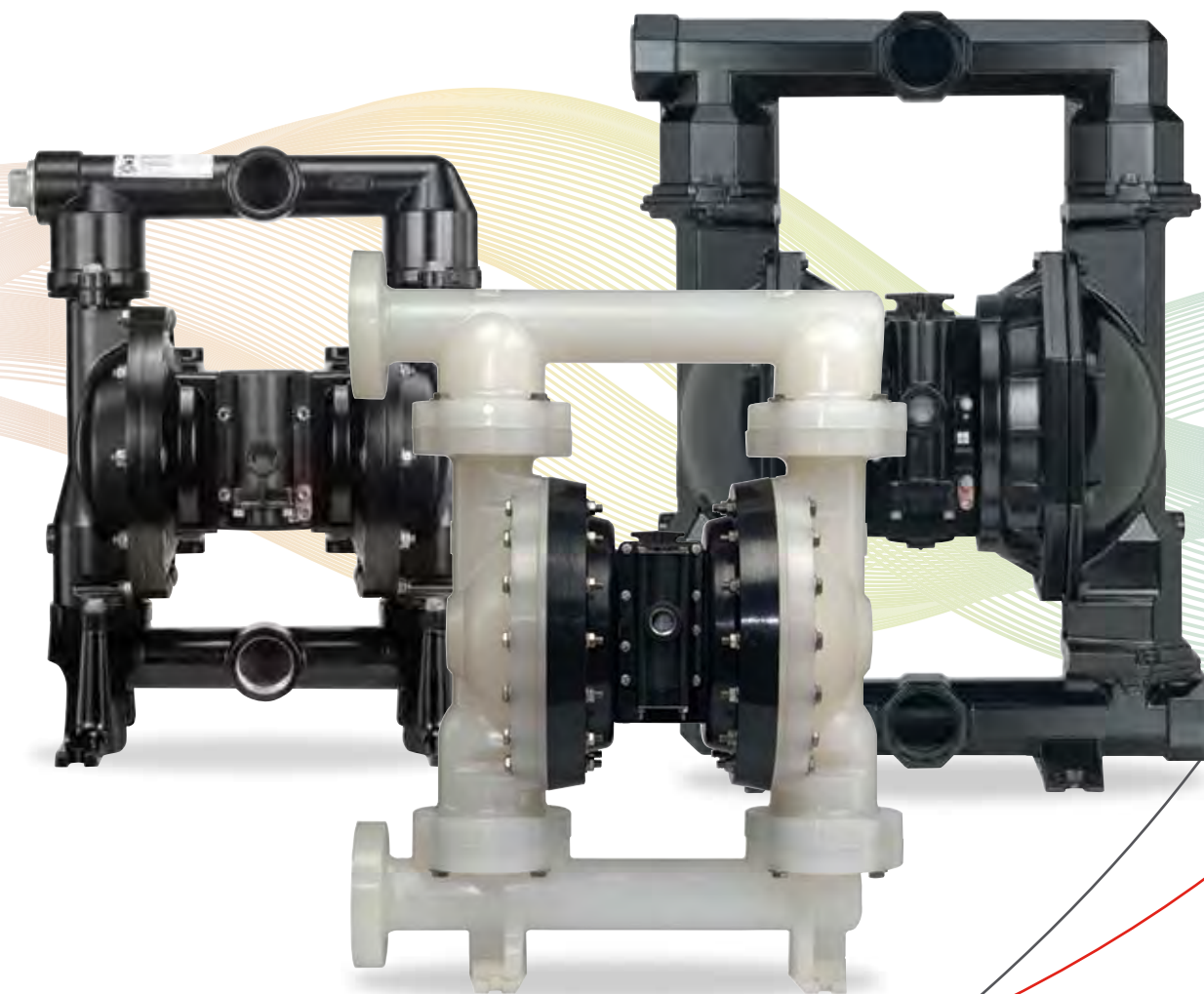



ARO® Air Operated Diaphragm Pumps

With proven performance in the field and backed by an industry leading 5-year warranty, ARO® air operated diaphragm pumps are a truly versatile fluid handling solution for numerous applications. Known for industry-leading efficiency, reliability, flow rates, and a large range of materials and porting, ARO® has the right pump to deliver consistency in the most demanding situations. The ARO® range of diaphragm pumps offers many materials of construction.

All ARO® pumps are available with convoluted diaphragms offering long product life and reduced maintenance.

Metallic Materials:

Aluminium
Cast Iron
Stainless Steel
Hastelloy®

Non-Metallic Materials:

Polypropylene
Acetal
PDVF

The Value of ARO® Air Operated Diaphragm Pumps

- ✔ Sealless design
- ✔ Handles abrasives, solids and corrosives
- ✔ Gentle fluid transfer
- ✔ Low shear
- ✔ Run-dry capability
- ✔ Portable
- ✔ Self priming
- ✔ Easy to install



ARO® Product and Technical Support

Every ARO® product is backed by a highly qualified team of engineers dedicated to designing products that promote success around the world. Because ARO® products are built to be as simple as they are smart, customers benefit from efficient operation and high performance for excellent total cost of ownership.

At ARO® we make success flow

Table of Contents

| | |
|------------------------------|----|
| ▶ Features | 4 |
| ▶ Non-Metallic Pump Overview | 9 |
| ▶ Non-Metallic Models | 10 |
| ▶ Metallic Pump Overview | 27 |
| ▶ Metallic Models | 28 |
| ▶ Controller | 40 |
| ▶ Specialty Pumps | 41 |
| Flap Valve | |
| Powder Pump | |
| Sanitary Transfer | |
| FDA Compliant | |
| High Pressure | |
| PW Series | |
| ARO® Station | |
| Automatic Dewatering | |
| Drum Pumps | |
| ▶ Accessories | 50 |
| ▶ Maintenance Kits | 56 |

ARO® EXP Series Diaphragm Pumps

ARO® EXP Series diaphragm pumps include all the benefits of standard air-operating pumps, but with significant additional features and benefits.

- Electronic Interface capability, assuring consistent flow rates and pinpoint control
- Patented SimulShift™ "unstallable" air balanced valve design which avoids stalling issues associated with other pumps
- Quick Dump™ check valves that divert cold exhaust air from ice-prone components, which prevents freezing and downtime
- Solenoid valve conveniently mounted directly to pump's major valve

What is the advantage of having a solenoid in the air valve instead of a solenoid in the airline?

The solenoid actuation allows for accurate cycle rate control and provides a more consistent volume per stroke than is achieved with standard pumps. Additionally, solenoid control allows for a precise number of cycles to be fully completed for improved batch repeatability.

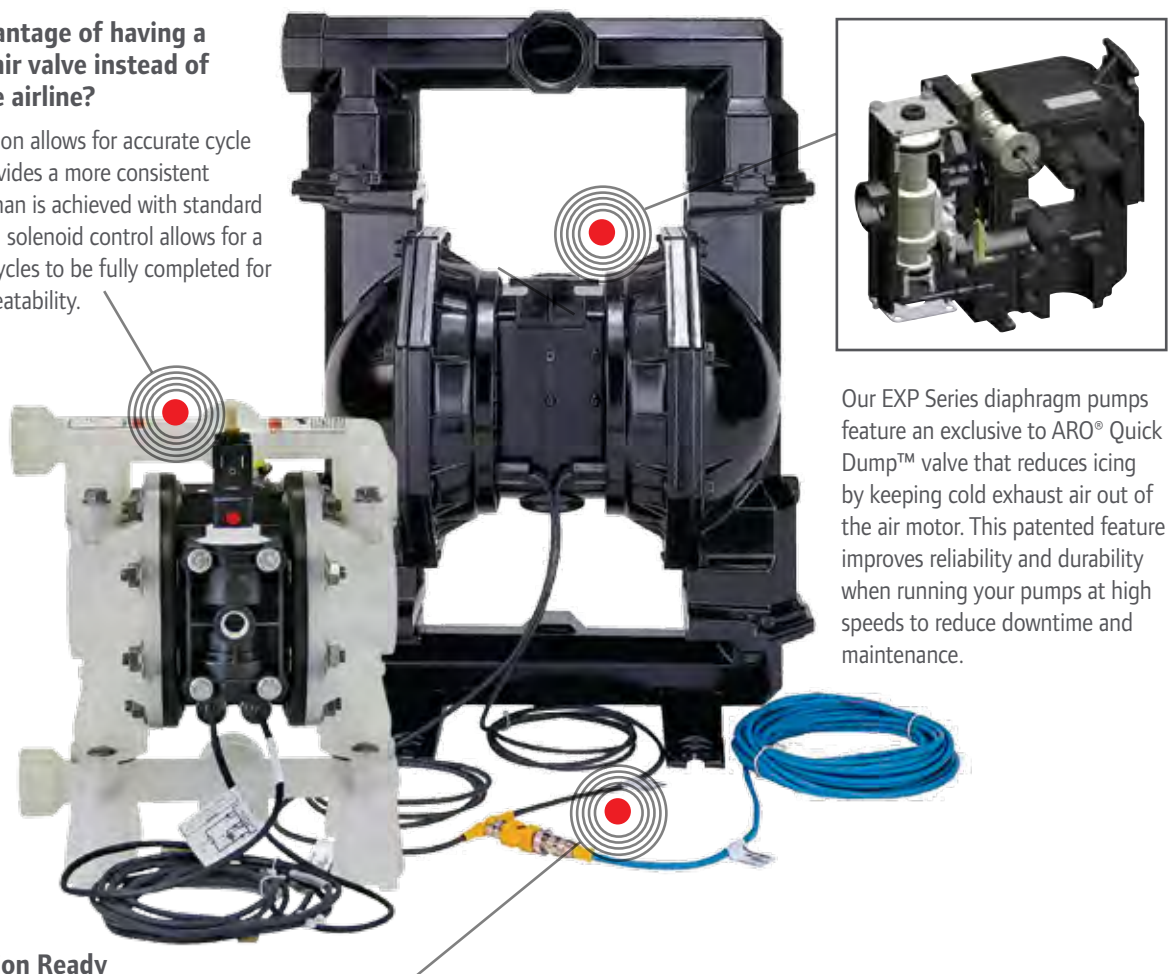

Our EXP Series diaphragm pumps feature an exclusive to ARO® Quick Dump™ valve that reduces icing by keeping cold exhaust air out of the air motor. This patented feature improves reliability and durability when running your pumps at high speeds to reduce downtime and maintenance.

EXP is Automation Ready

All EXP Series pumps are enhanced with electronic interface capability, providing accurate, electronically controlled dosing. Combine our pump with the ARO Controller or a PLC or PC based system and switch from inaccurate, inefficient manual processes to intelligent fluid management.

- EXP is compatible with almost any automation system
- Electronic Interface Pumps are now available for hazardous duty environments (ATEX, NEC, and CEC certifications)
- Leak detection option certified for use in ATEX/ and NEC/CEC locations detects diaphragm failure to help reduce costly production downtime
- Internal cycle sensor and end-of-stroke signals track end-of-stroke feedback and pump data
- Preassembled components for hassle-free and error-proof installation

EXP Benefits

ARO EXP offers industry leading Total Cost of Ownership

The purchase price of a traditional diaphragm pump is the smallest piece of the total pump cost-of-ownership pie. There are downtime costs, energy costs, parts costs and labor costs to consider as well. The unique features of our EXP Series mean you get industry leading total cost of ownership.

**EXP (ARO) vs. Leading Competitor
"Total Cost of Ownership"**

- Test Subjects: 2" (ports) aluminum construction with santoprene elastomer's.
- Pump Operation: 4 hrs. a day (intermittent)/ 300 days a year = 1200 hrs.
- Pump Delivery: 150 GPM @ 25 PSI (back pressure)
- Energy Cost: \$0.063 per kilowatt hour
- EXP Air CFM advantage: 37 @ 100 GPM

EXP Total Cost of Ownership cost savings per pump per year: \$742.00

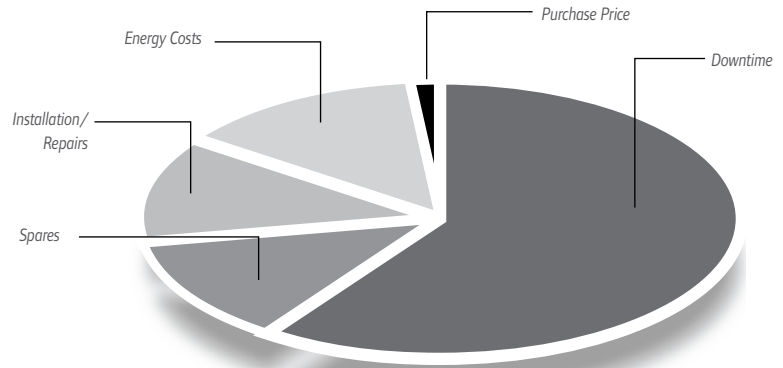

Note: Testing of pumps based on Hydraulic Institute / ANSI (10.6) air-operated pump test guidelines. All tests were conducted on new, out-of-the-box models. Both pumps were tested on Hydraulic Institute - conforming test loop at 25 PSI back pressure, pumping 150 gallons per minute. The fluid being pumped was water. For complete test guidelines and procedure information, contact the manufacturer.

EXP Reliability

| Traditional Downtime Problems | ARO EXP Solution | The Benefits |
|--|--|--|
| Pump Freezing | Quick Dump™ Checks | Downtime from Freezing Eliminated |
| Pump Stalling | SimulShift™ Valve / Unbalanced Air Valve | Process Production Uptime |
| Diaphragm Failure | Convolved Diaphragms | Up to 4X the Life of Traditional Diaphragms |
| Air Motor Corrosion Due to Chemical Attack | Engineered Thermoplastic Construction | Extended Pump Life |
| Pump Leakage | Engineered Bolted Construction | Zero Leakage Downtime, Safer, Cleaner Environment, Material Cost Savings |

EXP Efficiency

| Common Efficiency Issues | ARO EXP Solution | The Benefits |
|--|----------------------------------|-----------------------------------|
| Compressed Air "Blow-By" Caused by Inferior Design | Positive Seal, Ceramic "D" Valve | No Energy Wasted During Pump Idle |

EXP Serviceability

| Common Serviceability Issues | ARO EXP Solution | The Benefits |
|---|---|---|
| Labor/Time: Pulling & Replacing Failed Pumps Labor/Time: Tearing Down and Replacing Failed Parts Complex or Incomplete Service Kits | Longer Lasting Wear Parts i.e. Convolved Diaphragms Easy-Access Major Air Valve Simplified Service Kits | Significantly Reduced Labor and Parts Costs |

EXP Control and Monitoring

| Common Issues | ARO EXP Solution | The Benefits |
|---|--|---|
| Labor/Time: No integrated control solution | Safe control in hazardous locations | Simple to configure and operate |
| Cost and complexity tied to evolving a manual / unmonitored process | Upgradeable configurations (air to electrical control) | Simple upgradeable solution, ability to streamline end user process |

EXP provides safer control and monitoring

ARO® Compact and EXP Electronic Interface pumps are suitable for use in gas and dust environments, including ATEX and North American applications. Hazardous rated electrical components allow for installation within hazardous areas.

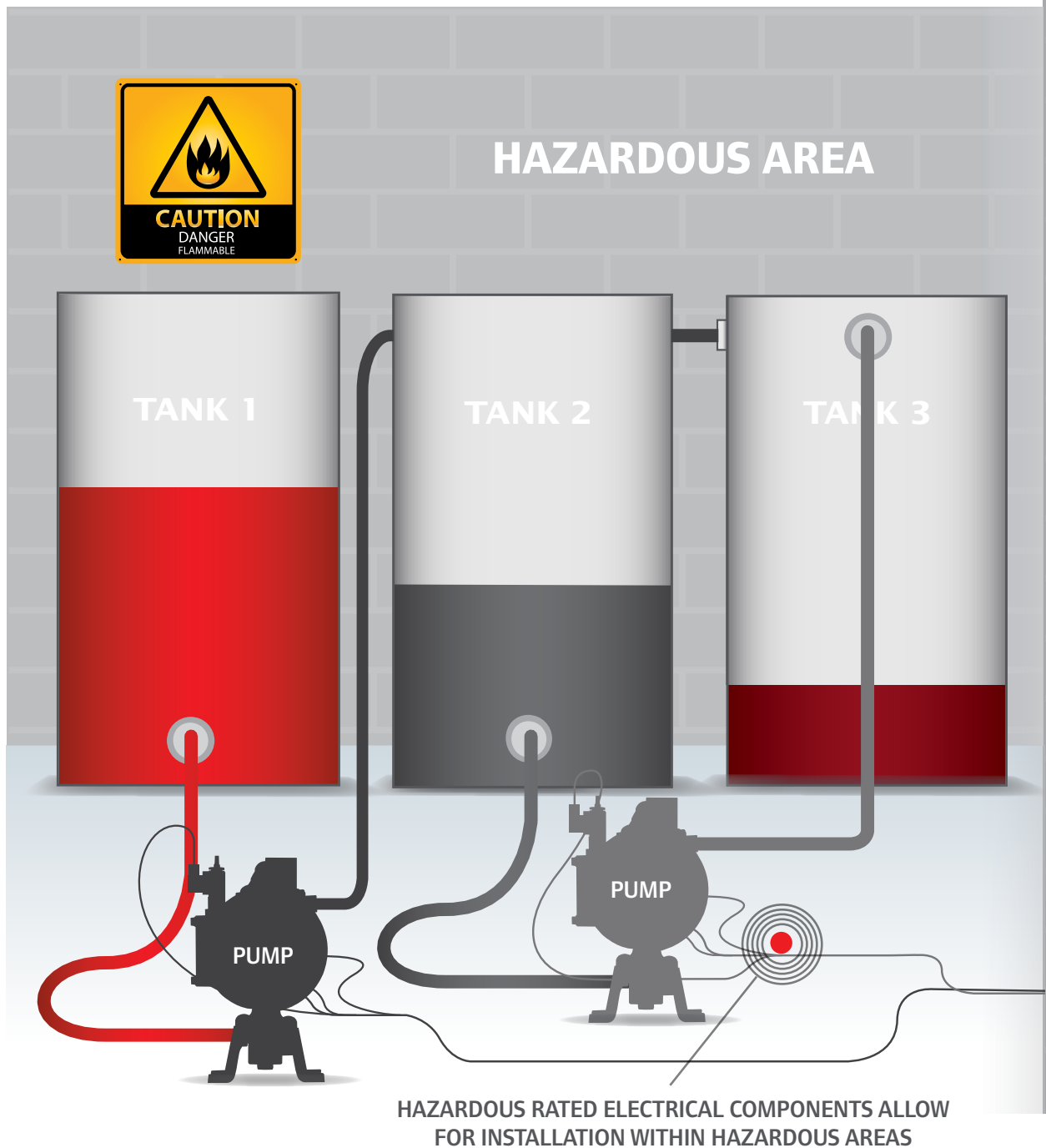

ARO EXP Electronic Interface pumps are ideal for pumping fluids such as solvents, ethanol or fuels and other potentially flammable materials in HD environments – such as Chemical processing, paint/finishing, energy, ethanol, oil and gas, on-shore and petrochemical and fuel transfer.

NON-HAZARDOUS AREA

SHIELDED WALL

CRITICAL ALERTS

CABLE GLAND

CAN BE CONTROLLED VIA
AN ARO® CONTROLLER,
CUSTOMIZED PLC OR A PC
BASED CONTROL SYSTEM

BARRIER
DEVICE

ENCLOSURE
FOR BARRIER
DEVICES

- ▶ Operate the pump in the following hazardous locations:
NEC / CEC: Class I&II, Div 1&2 ATEX: Zone 1&2, 21&22
- ▶ Wire the provided sensors and barrier devices per your local code requirements
- ▶ Install controller and barrier devices in a suitable hazardous enclosure or outside the hazardous area



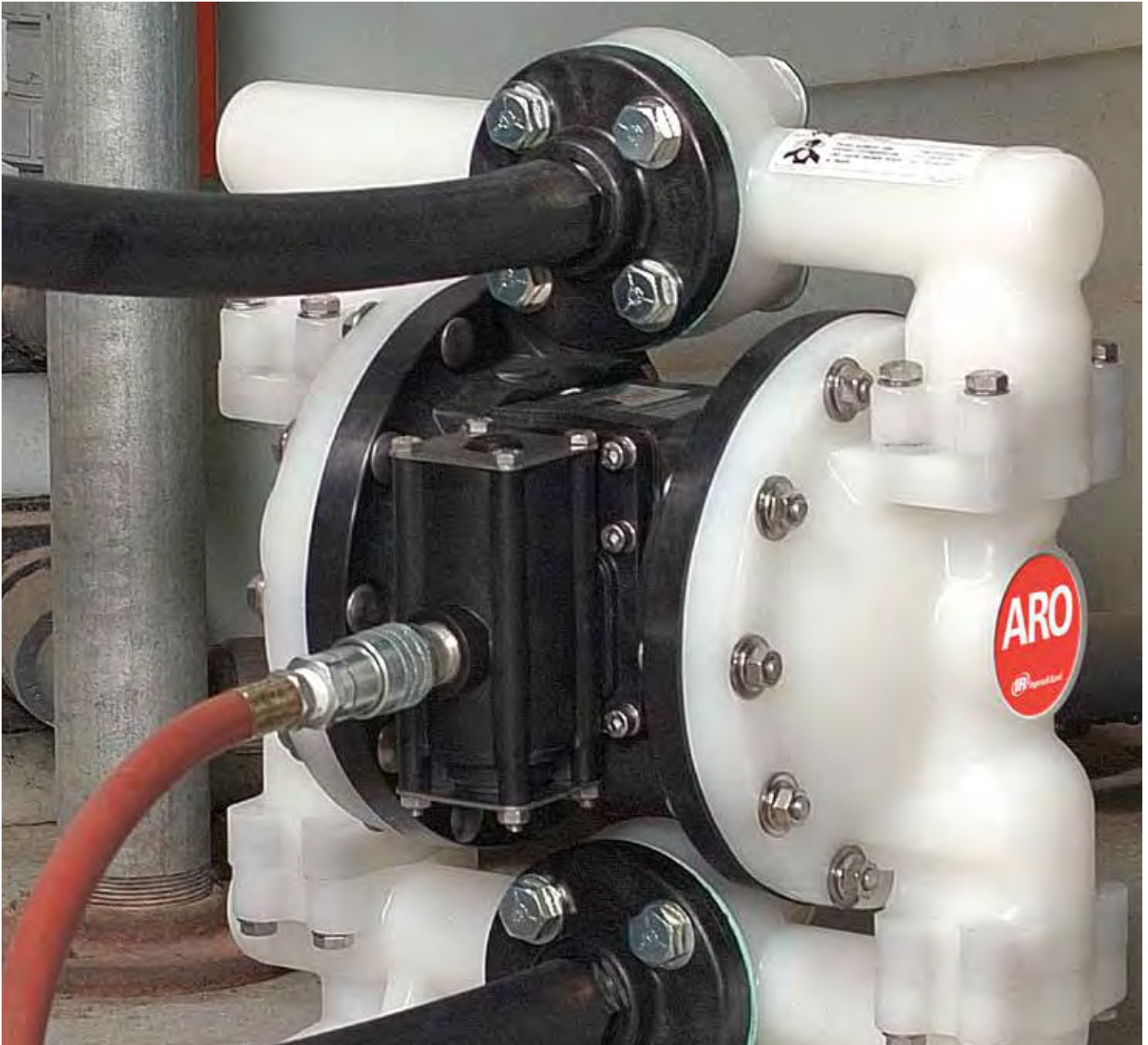

Non-Metallic Models

The ARO® EXP Series of non-metallic pumps consists of polypropylene, acetal and PDVF. All ARO® pumps are available with convoluted diaphragms offering long-lasting life and reduced maintenance.

Non-Metallic Model Overview

All 1/4" - 2" Non-metallic PD pumps are now upgradeable!

PD pumps are manufactured such that solenoid operation, flow monitoring and leak detection functionality can be added at a later date. As your processes mature, this capability allows you to enhance manually operated processes to incorporate additional control and monitoring capabilities. Simply remove two plugs and replace with a proximity sensor and (or) leak detector. Once upgraded, these components can also be integrated with the ARO® controller for seamless integration.

UPGRADE
PUMP FOR REMOTE
ACTUATION CAPABILITY



| Models | 1/4" Non-Metallic | 3/8" Non-Metallic | 1/2" Non-Metallic | 1/2" Classic Non-Metallic | 3/4" Non-Metallic | 1" Non-Metallic | 1-1/2" Non-Metallic | 2" Non-Metallic |
|--------------------------------------|---|--|--|--|---|---|---|--|
| Maximum Flow gpm (lpm) | 5.3 (20) | 10.6 (40.1) | 14.4 (54.5) | 13 (49.2) | 14.8 (56) | 53 (200) | 123 (465) | 184 (696) |
| Maximum Discharge Pressure psi (bar) | 125 (8.6) | 100 (6.8) | 100 (6.8) | 100 (6.9) | 100 (6.8) | 120 (8.3) | 120 (8.3) | 120 (8.3) |
| Fluid Ports Inlet/Outlet (bsp) | Q-1/4-1/8 PTF SAE SHORT | 3/8" (F) - In/Out | 1/2" (F) - In/Out | 1/2-14 N.P.T.F.-1 | 3/4 - 14 N.P.T.F.-1 Rp 3/4(3/4-14 BSP, parallel) | 1" ANSI/DIN Flange (Side or Center) 1 - 11-1/2" NPT Rp 1(1-11 BSP) (Center Discharge) | 1-1/2" ANSI/DIN Flange (Side or Center) | 2" ANSI/DIN Flange (Side Discharge) |
| Material of Construction | Polypropylene Groundable Acetal PVDF | Polypropylene Groundable Acetal PVDF | Polypropylene Groundable Acetal PVDF | Polypropylene Groundable Acetal PVDF | Polypropylene | Polypropylene PVDF Conductive Polypropylene | Polypropylene PVDF Conductive Polypropylene | Polypropylene PVDF Conductive Polypropylene |
| Pump Weight lbs (kg) | Poly 2.86 (1.3) PVDF 3.88 (1.76) Acetal 3.52 (1.6) | 4.2 (1.9) PD03P-XDS-X 4.3 (1.9) PD03P-XES-X 4.5 (2.0) PD03P-XKS-X 4.6 (2.1) PD03P-XLS-X 3.4 (1.6) PD03P-XPS-X 3.5 (1.6) PD03P-XRS-X | 6.3 (2.9) PD05P-XDS-X-B 6.7 (3.0) PD05P-XES-X-B 6.8 (3.1) PD05P-XKS-X-B 7.2 (3.3) PD05P-XLS-X-B 5.2 (2.4) PD05P-XPS-X-B 5.4 (2.5) PD05P-XRS-X-B | 7.2 (3.3) Polypropylene 8.8 (4.0) Ground. Acetal 9.5 (4.3) Kynar PVDF | 5.61 (2.54) | 19.35 (8.78) Poly Threaded 19.59 (8.89) Poly Center Port 19.87 (9.01) Poly Side Port 25.83 (11.72) PVDF Threaded 26.72 (12.12) PVDF Center Port 27.15 (12.32) PVDF Side Port | 42.30 (19.19) Poly Center Port 42.60 (19.32) Poly Side Port 55.94 (25.37) PVDF Center Port 63.94 (29.0) PVDF Side Port | 85.3 (38.7) Poly 110.9 (50.3) PVDF |
| Maximum Solids in (mm) | 1/16 (1.6) | 1/16 (1.6) | 3/32 (2.4) | 3/32 (2.4) | 3/32 (2.4) | 1/8 (3.2) | 1/4 (6.4) | 1/4 (6.4) |
| Maximum Dry Suction Lift ft (m) | 15 (4.6) | 9.25 (2.8) | 15 (4.5) | 15 (4.5) | 15 (4.5) | 19 (5.7) | 14 (4.2) | 14 (4.2) |
| Recommended Filter/Regulator | P39124-620 | P39124-600 | P39124-600 | P39124-624 | P39124-600 | P39224-600 | P39334-600 | P39454-610 |
| Airline Kit | 66073-1 | 66073-1 | 66073-1 | 66073-1 | 66073-1 | 66073-2 | 66084-1 | 66109 |

1/4" Non-Metallic Models

COMPACT SERIES PUMPS

Part of our Compact Series of pumps, our 1/4" pumps feature big performance in a compact package. They feature flow rates up to 5.3 GPM (20 LPM), a wide range of material options, multi-port versions and the unique hybrid male/female threaded fluid connections.

UPGRADE
PUMP FOR REMOTE
ACTUATION CAPABILITY

| | |
|-------------------------------------|--|
| Ratio: | 1:1 |
| Maximum Flow: | 5.3 g.p.m. (20) l.p.m. |
| Displacement per cycle: | 0.019 Gallons (0.072 Liters) |
| Air Inlet (Female): | 1/4 - 18 PTF SAE Short |
| Fluid Inlet/Outlet Hybrid: | Internal Thread 1/4"NPTF/BSPT External Thread 3/4" - 14 NPTF/BSPT |
| Max. operating pressure psi (bar): | 125 (8.6) |
| Suspended solids max. dia. in.(mm): | 1/16" (1.66) |
| Weight lbs (kg): | 2.86 (1.3) Polypropylene 3.88 (1.76) PVDF 3.52 (1.60) Acetal |
| Maximum dry suction lift ft(m) : | 15 (4.6) |
| Sound Level: | 70 PSI 60 Cycles/Min 62.3 db(A) |
| Muffler: | Integral, Included |



PD01P-HPS-PCC-A

Ordering

| Position | 1 | 2 | | 3 | 4 | 5 | | 6 | 7 | 8 | | 9 | | 10 | 11 |
|----------|-------|---|---|---|---|---|---|---|---|---|---|---|---|----|----|
| Example: | PX01P | X | - | H | X | S | - | X | X | X | - | A | - | X | X |

| Position 1 Model Series | Position 2 Center Section | Position 3 Fluid Connections | Position 4 Wetted Parts | Position 5 Hardware | Position 6 Seat Material | Position 7 Ball Material | Position 8 Diaphragm Material | Position 9 Revision | Position 10 & 11 Specialty Code |
|--|---|------------------------------------|--|------------------------|---|--|---|------------------------|--|
| PD01 - Standard Pump PE01 - Elec. Interface Accessible Pump | E - Conductive Polypropylene P - Polypropylene | H - 1/4" NPT BSP hybrid | D - Groundable Acetal* E - Groundable Acetal* (Multiple port) K - Kynar PVDF L - Kynar PVDF (Multiple port) P - Polypropylene R - Polypropylene (Multiple port) | S - Stainless Steel | D - Acetal K - PVDF P - Polypropylene 0 - Polypropylene (Flex-Check spacer)* 1 - Acetal (Flex-Check spacer)* 2 - PVDF (Flex-Check spacer)* | A - Santoprene® C - Hytrel® G - Nitrile J - Nitrile (Flex-Check only) K - EPR (Flex-Check only) L - Viton (Flex-Check only) N - Neoprene (Flex-Check only) T - PTFE | A - Santoprene® C - Hytrel® G - Nitrile T - PTFE | A - Revision 1 | Fluid control options for pump with electronic interface (PE01 model). See complete description on page 11 |

* Acceptable for use in hazardous locations. - NEC / CEC: Class I&II, Div 1&2
- ATEX: Zone 1&2, 21&22

Hytrel® and Viton® are registered trademarks of the DuPont company. Santoprene® is a registered trademark of Monsanto Company, licensed to Advanced Elastomer Systems, L.P.

Accessories

Air Line Connection Kit | 66073-1

(Piggyback Filter/Regulator with gauge, pipe nipple and 5-foot air hose)

1/4" Non-Metallic Dimensions and Flow Charts

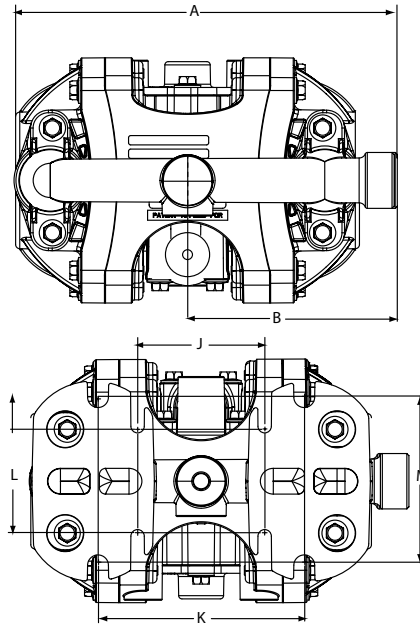
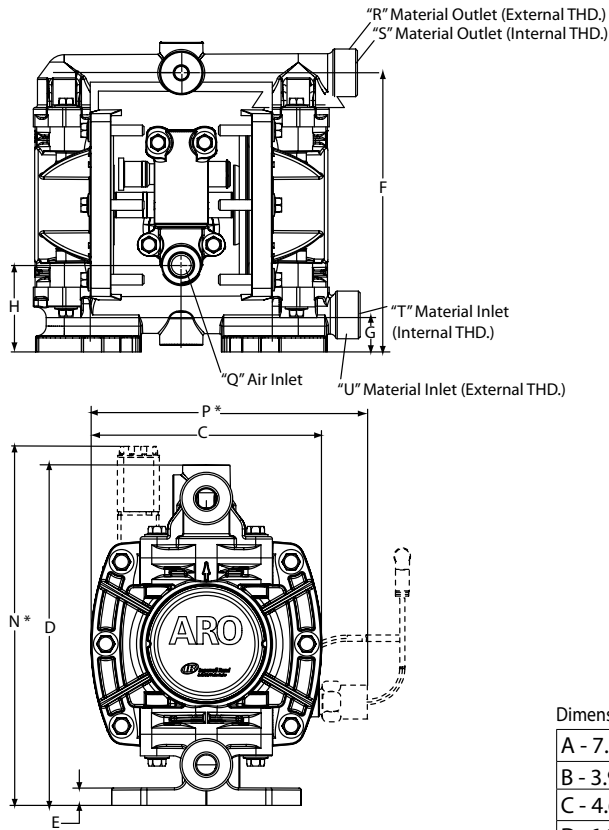

DIMENSIONS

Dimensions shown are for reference only, they are displayed in inches and millimeters (mm).

| | | |
|---------------------|---------------------|----------------------------|
| A - 7.2" (182 mm) | H - 1.9" (48.6 mm) | Q - 1/4 - 18 PTF SAE Short |
| B - 3.9" (100.0 mm) | J - 2.4" (61 mm) | R - 3/4-14 NPTF |
| C - 4.6" (117.0 mm) | K - 3.9" (99 mm) | S - 1/4 NPTF / BSPT Hybrid |
| D - 6.8" (173.0 mm) | L - 2.1" (53 mm) | T - 1/4 NPTF / BSPT Hybrid |
| E - 0.3" (8.8 mm) | M - 3.2" (81 mm) | U - 3/4-14 NPTF |
| F - 6.1" (156 mm) | N - 7.2" (184 mm) | V - 1/4 NPTF |
| G - 0.8" (20.7 mm) | P - 5.6" (142.2 mm) | |

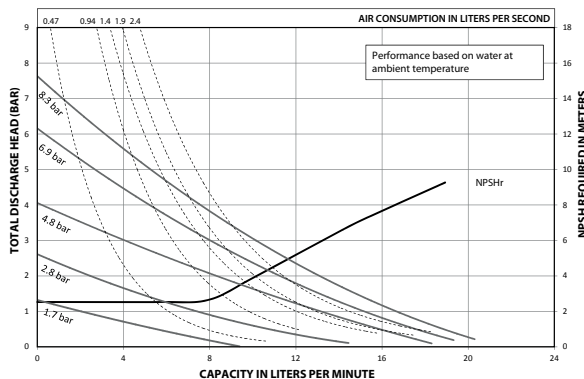
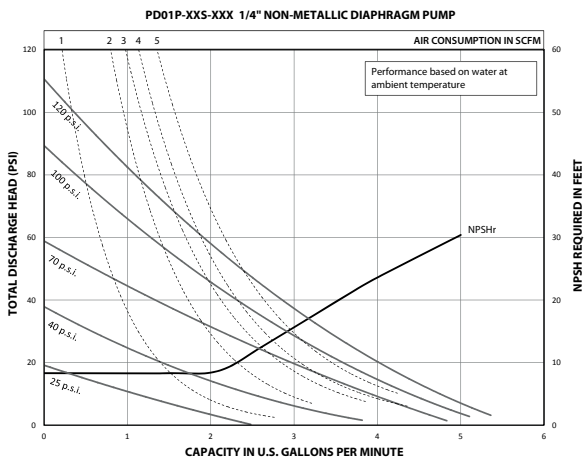

Ordering Position 10

Specialty Code 1 (Blank if no Specialty Code)

- | | |
|---------------------|--|
| A - Solenoid 120VAC | G - Solenoid 12VDC ATEX/IECex* |
| B - Solenoid 12VDC | H - Solenoid 24VDC ATEX/IECex* |
| C - Solenoid 240VAC | J - 120VAC NEC/CEC* |
| D - Solenoid 24VDC | K - Solenoid 220VAC ATEX/IECex* |
| E - 12VDC NEC/CEC* | N - Solenoid with no coil |
| F - 24VDC NEC/CEC* | O - Standard Valve Block (No Solenoid) |

Ordering Position 11

Specialty Code 2 (Blank if no Specialty Code)

- | | |
|--|--|
| E - End of stroke feedback + Leak Detection | L - Leak Detection |
| F - End of stroke feedback | M - Leak Detection ATEX/IECex/NEC/CEC* |
| G - End of Stroke ATEX/IECex* | O - No Option |
| H - End of Stroke/Leak Detection ATEX/IECex* | R - End of Stroke Feedback NEC / CEC* |
| | T - End of Stroke Feedback + Leak Detection NEC / CEC* |

* Acceptable for use in hazardous locations. - NEC / CEC: Class I&II, Div 1&2
 - ATEX: Zone 1&2, 21&22

3/8" Non-Metallic Models

COMPACT SERIES PUMPS

Part of our Compact Series of pumps, our 3/8" pumps feature big performance in a small package. They feature flow rates up to 10.6 GPM (40.1 LPM) and a wide range of material and porting configurations.

UPGRADE
PUMP FOR REMOTE
ACTUATION CAPABILITY

Ratio: 1:1
 Maximum Flow: 10.6 g.p.m. (40.1 l.p.m.) 8.7 (32.9) Flex check
 Displacement per cycle: 0.022 Gallons (0.083-Liters) 0.018 (0.068) Flex check
 Air Inlet: (Female) 1/4 - 18 P.T.F. SAE Short
 Fluid Inlet/Outlet: 3/8 - 18 N.P.T.F. - 1
 Rp 3/8 (3/8 - 19 BSP, parallel)
 Max. operating pressure: 100 psi (6.9-bar)
 Suspended solids max. dia.: 1/16-in. (1.6-mm) Flex check (Fibers)
 Weight: lbs (kg)
 PD03P-XDS-XXX 4.2 (1.9)
 PD03P-XES-XXX 4.3 (1.9)
 PD03P-XKS-XXX 4.5 (2.0)
 PD03P-XLS-XXX 4.6 (2.1)
 PD03P-XPS-XXX 3.4 (1.6)
 PD03P-XRS-XXX 3.5 (1.6)
 Maximum dry suction lift: ft (m) 9.25 (2.8)
 Sound Level: 70 PSI 60 Cycles/Min 72.7 db(A)
 Muffler: Integral, Included



PD03P-BPS-PCC



PD03P-BDS-DTT



Ordering

| Position | 1 | 2 | | 3 | 4 | 5 | | 6 | 7 | 8 | | 9 | | 10 | 11 |
|----------|------|---|---|---|---|---|---|---|---|---|---|---|---|----|----|
| Example: | PX03 | P | - | X | X | S | - | X | X | X | - | B | - | X | X |

| Position 1 Model Series | Position 2 Center Section | Position 3 Connections | Position 4 Manifold Material | Position 5 Hardware | Position 6 Seat Material | Position 7 Ball Material | Position 8 Diaphragm Material | Position 9 |
|--|---------------------------------|------------------------------------|--|------------------------|--|--|--|--|
| D - Standard E - Remote Actuation Capable | P - Poly- propylene | A - 3/8" N.P.T. B - 3/8" BSP | D - Ground. Acetal (single port)* E - Ground. Acetal (multiple port)* K - PVDF (single port) L - PVDF (multiple port) P - Polypropylene (single port) R - Polypropylene (multiple port) | S - Stainless Steel | D - Acetal K - PVDF P - Poly- propylene S - Stainless Steel O - Flex Check | A - Santoprene® C - Hytrel® I - Nitrile N - Neoprene S - Stainless Steel T - PTFE V - Viton | A - Santoprene® C - Hytrel® G - Nitrile T - PTFE/ Santoprene® V - Viton * Flex check models | Revision Level Position 10 & 11 Specialty Code Fluid control options for pump with electronic interface (PE03 model). See com- plete description on page 13 |

* Acceptable for use in hazardous locations. - NEC / CEC: Class I&II, Div 1&2
 - ATEX: Zone 1&2, 21&22

Accessories

Air Line Connection Kit | 66073-1

(Piggyback Filter/Regulator with gauge, pipe nipple and 5-foot air hose)

Cycle Counter Kit | 66975

Wall Mount Bracket Kit | 67388

Optional Muffler | used with 637428 kit

Service Repair Kits | 637428 (air section)

637429-XX (fluid section)



Air Line Connection Kit
66073-1

Wall Mount Bracket Kit
67388

3/8" Non-Metallic Dimensions and Flow Charts



PE03P-APS-PAA-BOS
with 637442-1 Kit

- Dual Inlet/Outlet Kits:
 637442-1 (N.P.T. Poly)
 637442-4 (BSP Poly)
 637442-3 (N.P.T. PVDF)
 637442-6 (BSP PVDF)
 637442-2 (N.P.T. Acetal)
 637442-5 (BSP Acetal)

DIMENSIONS

- | | | |
|-----------------------|----------------------|-----------------------|
| A 7-29/32" (200.2 mm) | F 4-7/8" (123.9 mm) | L 1-3/32" (27.8 mm) |
| B 8-7/16" (214.3 mm) | G 9-7/32" (234.2 mm) | M 3/8" (9.5 mm) |
| C 5-9/16" (141.3 mm) | H 4" (101.6 mm) | N 4-11/32" (110.1 mm) |
| D 1-1/4" (31.8 mm) | J 4-3/4" (120.7 mm) | P 4-11/32" (110.3 mm) |
| E 5-23/32" (145.2 mm) | K 9/32" (7.1 mm) | Q 2-25/32" (70.6 mm) |

- | | | |
|---------------|-----------------------|-----------------------|
| Model | "R" Material Inlet | "S" Material Outlet |
| PD03P-AXS-XXX | 3/8 - 18 N.P.T.F. - 1 | 3/8 - 18 N.P.T.F. - 1 |
| PD03P-BXS-XXX | Rp 3/8 (3/8 - 19 BSP) | Rp 3/8 (3/8 - 19 BSP) |

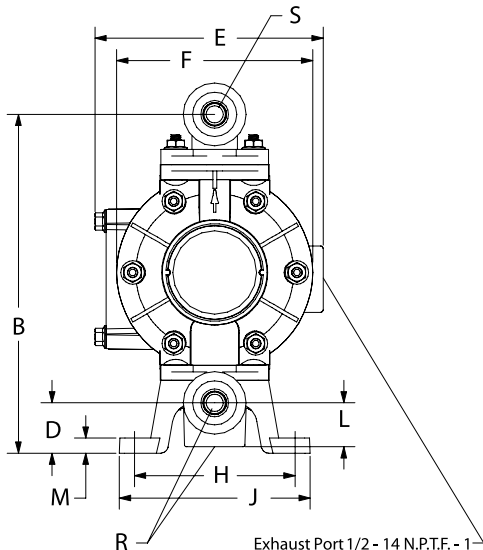
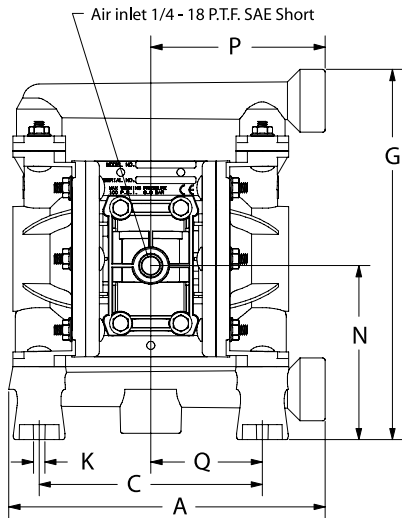

PERFORMANCE CURVES

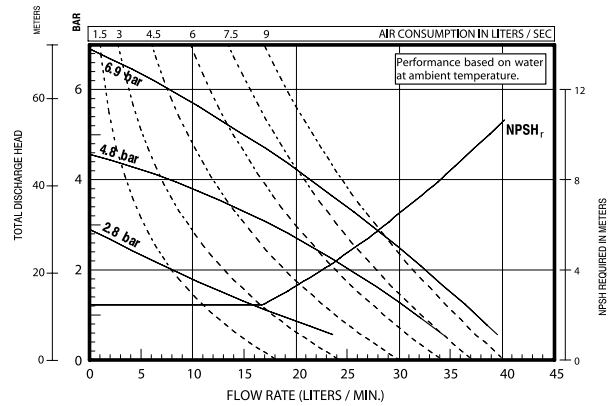
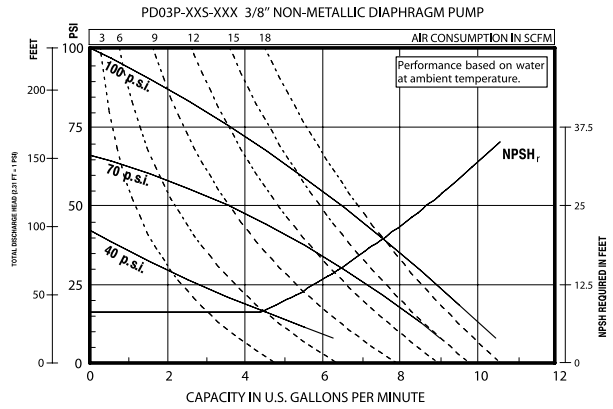

Refer to www.AROzone.com for full size flow curves.
 For additional information contact
 technical support at 1.800.495.0276

Ordering Position 10

Specialty Code 1 (Blank if no Specialty Code)

- | | |
|---------------------|---|
| A - Solenoid 120VAC | G - Solenoid 12VDC ATEX/IECex* |
| B - Solenoid 12VDC | H - Solenoid 24VDC ATEX/IECex* |
| C - Solenoid 240VAC | J - 120VAC NEC/CEC* |
| D - Solenoid 24VDC | K - Solenoid 220VAC ATEX/IECex* |
| E - 12vDC NEC/CEC* | N - Solenoid with no coil |
| F - 24vDC NEC/CEC* | O - Standard Valve Block (No Solenoid) |
| | P - Ported Mortor (No major valve provided) |

Ordering Position 11

Specialty Code 2 (Blank if no Specialty Code)

- | | |
|--|--|
| E - End of stroke feedback + Leak Detection | L - Leak Detection |
| F - End of stroke feedback | M - Leak Detection ATEX/IECex/NEC/CEC* |
| G - End of Stroke ATEX/IECex* | O - No Option |
| H - End of Stroke/Leak Detection ATEX/IECex* | R - End of Stroke Feedback NEC / CEC* |
| | T - End of Stroke Feedback + Leak Detection NEC / CEC* |

* Acceptable for use in hazardous locations. - NEC / CEC: Class I&II, Div 1&2
 - ATEX: Zone 1&2, 21&22

1/2" Non-Metallic Models

COMPACT SERIES PUMPS

Part of our Compact Series of pumps, our 1/2" compact pumps feature big performance in a small package. They offer flow rates up to 14.4 GPM (54.5 LPM) and a wide range of material and porting configurations.

UPGRADE
PUMP FOR REMOTE
ACTUATION CAPABILITY

| | | | |
|----------------------------------|---|---------------|------------|
| Ratio: | 1:1 | | |
| Maximum Flow: | 14.4 g.p.m. (54.5 l.p.m.) | | |
| Displacement per cycle: | 0.039 Gallons (0.15 Liters) | | |
| Air Inlet: (Female) | 1/4 - 18 P.T.F. SAE Short | | |
| Fluid Inlet/Outlet: | 1/2 - 14 N.P.T.F. - 1 Rp 1/2 (1/2 -14 BSP, parallel) | | |
| Max. operating pressure: | 100 psi (6.9 bar) | | |
| Suspended solids max. dia.: | 3/32" (2.4 mm) | | |
| Weight: lbs (kg) | PD05P-XDS-XXX-B | 6.3 (2.9) | |
| | PD05P-XES-XXX-B | 6.7 (3.0) | |
| | PD05P-XKS-XXX-B | 6.8 (3.1) | |
| | PD05P-XLS-XXX-B | 7.2 (3.3) | |
| | PD05P-XPS-XXX-B | 5.2 (2.4) | |
| | PD05P-XRS-XXX-B | 5.4 (2.5) | |
| Maximum dry suction lift: ft (m) | 15.0 (4.5) | | |
| Sound Level: | 70 PSI | 60 Cycles/Min | 75.0 db(A) |
| Muffler: | Integral, Included | | |



PD05P-BRS-PAA

Ordering

| Position | 1 | 2 | | 3 | 4 | 5 | | 6 | 7 | 8 | | 9 | | 10 | 11 |
|----------|------|---|---|---|---|---|---|---|---|---|---|---|---|----|----|
| Example: | PX05 | P | - | X | X | S | - | X | X | X | - | B | - | X | X |

| Position 1 Model Series | Position 2 Center Section | Position 3 Connections | Position 4 Manifold Material | Position 5 Hardware | Position 6 Seat Material | Position 7 Ball Material | Position 8 Diaphragm Material | Position 9 |
|--|---------------------------------|---|--|------------------------|--|--|---|---|
| D - Standard E - Remote Actuation Capable | P - Poly- propylene | A - 1/2 - 14 N.P.T.F. - 1 B - Rp 1/2 (1/2 -14 BSP, parallel) | D - Ground. Acetal (single port)* E - Ground. Acetal (multiple port)* K - PVDF (single port) L - PVDF (multiple port) P - Polypropylene (single port) R - Polypropylene (multiple port) | S - Stainless Steel | D - Acetal K - PVDF P - Poly- propylene S - Stainless Steel | A - Santoprene® C - Hytrel® * G - Nitrile S - Stainless Steel T - PTFE U - Polyurethane V - Viton | A - Santoprene® C - Hytrel® * G - Nitrile L - Long-Life PTFE T - PTFE/ Santoprene® U - Polyurethane V - Viton | Revision Level Position 10 & 11 Specialty Code Fluid control options for pump with elec- tronic interface (PE05 model). See complete description on page 15 |

* Acceptable for use in hazardous locations. - NEC / CEC: Class I&II, Div 1&2
- ATEX: Zone 1&2, 21&22

Accessories

Air Line Connection Kit | 66073-1

(Piggyback Filter/Regulator with gauge, pipe nipple and 5-foot air hose)

Cycle Counter Kit | 66975

Wall Mount Bracket Kit | 76763

Optional Muffler | 93110 used with 637438 kit

Service Repair Kits | 637428 (air section)

637427-XX (fluid section)



Air Line Connection Kit
66073-1

1/2" Non-Metallic Dimensions and Flow Charts

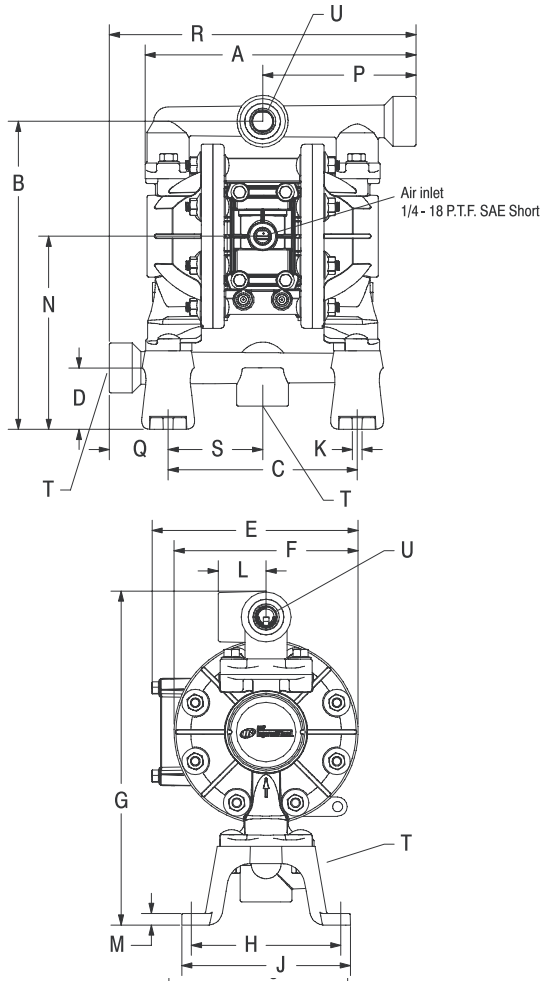

DIMENSIONS

| | | |
|-----------------------|----------------------|----------------------|
| A 8-27/32" (224.3 mm) | G 10-7/8" (275.7 mm) | N 6-5/16" (159.9 mm) |
| B 10-1/16" (255.0 mm) | H 4-7/8" (123.8 mm) | P 5" (127.0 mm) |
| C 6.164" (156.6 mm) | J 5-1/2" (139.7 mm) | Q 1-59/64" (48.8 mm) |
| D 2" (50.8 mm) | K 5/16" (8.0 mm) | R 10" (254.0 mm) |
| E 6-23/32" (170.6 mm) | L 1-9/16" (39.7 mm) | S 3-3/32" (78.3 mm) |
| F 6" (152.4 mm) | M 3/8" (9.5 mm) | |

| | | |
|-----------------|---------------------------|----------------------------|
| Model | "T" Material Inlet | "U" Material Outlet |
| PD05P-AXS-XXX-B | 1/2 - 14 N.P.T.F. - 1 | 1/2 - 14 N.P.T.F. - 1 |
| PD05P-EXS-XXX-B | Rp 1/2 (1/2 - 14 BSP) | Rp 1/2 (1/2 - 14 BSP) |



PE05P-APS-PAA-B05
with 637440-1 Kit

- Dual Inlet/Outlet Kits:
- 637440-1 (N.P.T. Poly)
 - 637440-4 (BSP Poly)
 - 637440-2 (N.P.T. Acetal)
 - 637440-5 (BSP Acetal)
 - 637440-3 (N.P.T. PVDF)
 - 637440-6 (BSP PVDF)

PERFORMANCE CURVES

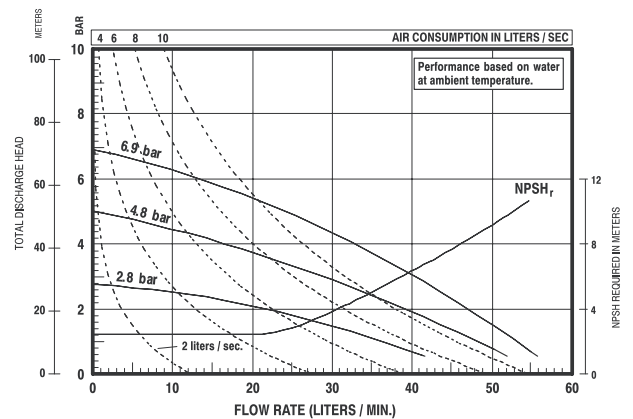
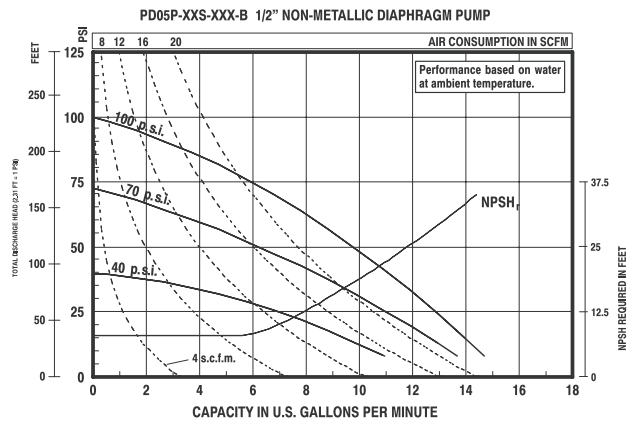

Refer to www.AROzone.com for full size flow curves.

For additional information contact
technical support at 1.800.495.0276

Ordering Position 10

Specialty Code 1 (Blank if no Specialty Code)

- | | |
|---------------------|---|
| A - Solenoid 120VAC | G - Solenoid 12VDC ATEX/IECex* |
| B - Solenoid 12VDC | H - Solenoid 24VDC ATEX/IECex* |
| C - Solenoid 240VAC | J - 120VAC NEC/CEC* |
| D - Solenoid 24VDC | K - Solenoid 220VAC ATEX/IECex* |
| E - 12VDC NEC/CEC* | N - Solenoid with no coil |
| F - 24VDC NEC/CEC* | O - Standard Valve Block (No Solenoid) |
| | P - Ported Mortor (No major valve provided) |

Ordering Position 11

Specialty Code 2 (Blank if no Specialty Code)

- | | |
|--|--|
| E - End of stroke feedback + Leak Detection | L - Leak Detection |
| F - End of stroke feedback | M - Leak Detection ATEX/IECex/NEC/CEC* |
| G - End of Stroke ATEX/IECex* | O - No Option |
| H - End of Stroke/Leak Detection ATEX/IECex* | R - End of Stroke Feedback NEC / CEC* |
| | T - End of Stroke Feedback + Leak Detection NEC / CEC* |

* Acceptable for use in hazardous locations. - NEC / CEC: Class I&II, Div 1&2
- ATEX: Zone 1&2, 21&22

1/2" Classic Style Non-Metallic Models

COMPACT SERIES PUMPS

Part of our Compact Series of pumps, our 1/2" classic pumps feature big performance in a small package. With flow rates up to 13 GPM (49.2 LPM) and a wide range of material and porting configurations.

| | |
|----------------------------------|--|
| Ratio: | 1:1 |
| Maximum Flow: | (ball) 13 g.p.m. (49.2 l.p.m.) (duckbill) 10 g.p.m. (37.9 l.p.m.) |
| Displacement per cycle: | (ball) 0.04 g.p.m. (0.15 l.p.m.) (duckbill) 0.032 g.p.m. (0.12 l.p.m.) |
| Air Inlet: (Female) | 1/4 - 18 N.P.T.F. - 1 |
| Fluid Inlet/Outlet: | 1/2 - 14 N.P.T.F. - 1 |
| Max. operating pressure: | 100 psi (6.9 bar) |
| Suspended solids max. dia.: | (ball) 3/32" (2.4-mm) (duckbill) fibers |
| Weight: lbs (kg) | Polypropylene 7.2 (3.3) Groundable Acetal 8.8 (4.0) Kynar PVDF 9.5 (4.3) |
| Maximum dry suction lift ft(m) : | 15 (4.6) |
| Sound Level: | 70 PSI 60 Cycles/Min 71.1 db(A) |
| Muffler: | Integral, Included |



Ordering

| Position | 1 | 2 | | 3 | 4 | 5 | | 6 |
|----------|-------|---|---|---|---|---|---|----|
| Example: | 66605 | X | - | X | X | X | - | 04 |

| Position 1 Model Series | Position 2 Fluid Caps and Manifold Material | Position 3 Seat Section | Position 4 Ball Material | Position 5 Diaphragm Material | Position 6 Cone Check Flow |
|----------------------------|---|--|---|--|-------------------------------|
| Base Model | 3 - Polypropylene 6 - Groundable Acetal 7 - Pure PVDF J - Polypropylene* H - Groundable Acetal* K - Pure PVDF* *Single piece manifold | 0 - Duckbill 2 - Stainless Steel 3 - Polypropylene 4 - PVDF 6 - Acetal | 1 - Neoprene 2 - Nitrile 3 - Viton 4 - PTFE 5 - E.P.R. 8 - Polyurethane A - Stainless Steel C - Neoprene** D - Nitrile** E - Santoprene **Duckbill models | 1 - Neoprene 2 - Nitrile 3 - Viton 4 - PTFE/Santoprene® 5 - E.P.R. 8 - Polyurethane 9 - Hytrel® B - Santoprene® L - Long-Life PTFE | 04 - Top Discharge |

Accessories

Air Line Connection Kit | 66073-1

(Piggyback Filter/Regulator with gauge, pipe nipple and 5-foot air hose)

Cycle Counter Kit| 66975

Optional Muffler | 93110 used with 637438 kit

Service Repair Kits | 637141 (air section)

637140-XX (fluid section)



93110



Air Line Connection Kit
66073-1

1/2" Non-Metallic Dimensions and Flow Charts

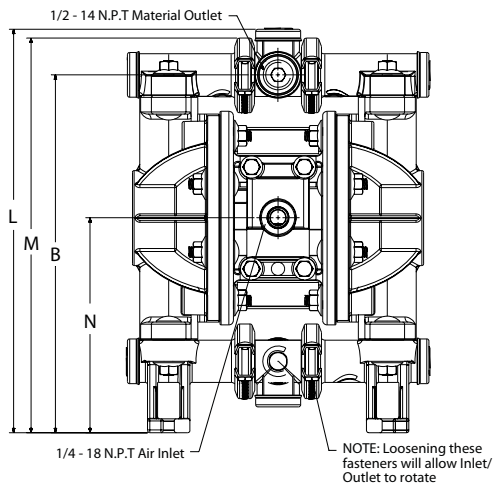
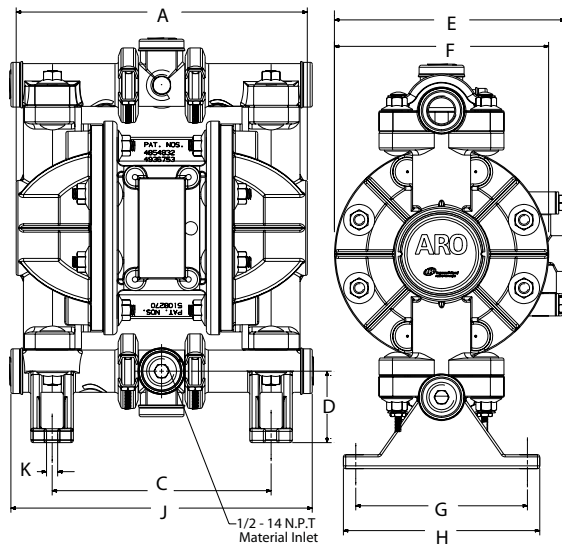

NOTE: Dimensions are shown in inches and (mm) and are supplied for reference only.

| | | |
|-----------------------|-----------------------|-----------------------|
| A - 8.155" (207.1 mm) | E - 6.467" (164 mm) | J - 8.44 5" (215 mm) |
| B - 10.051" (255 mm) | F - 6.000" (152 mm) | K - 0.31 2" (8 mm) |
| C - 6.135" (155.8 mm) | G - 4.812" (122.2 mm) | L - 11.331" (288 mm) |
| D - 2.005" (51 mm) | H - 5.500" (140 mm) | M - 11.08 4" (282 mm) |
| | | N - 6.040" (153 mm) |

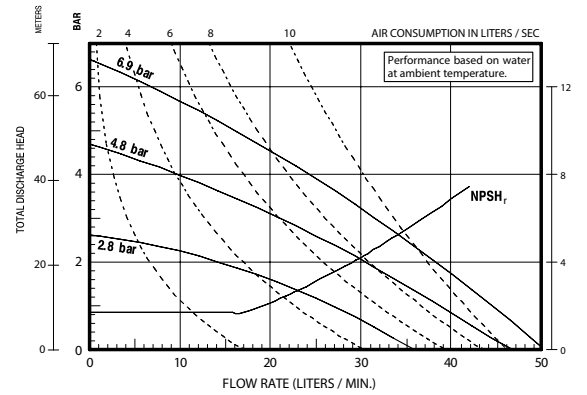
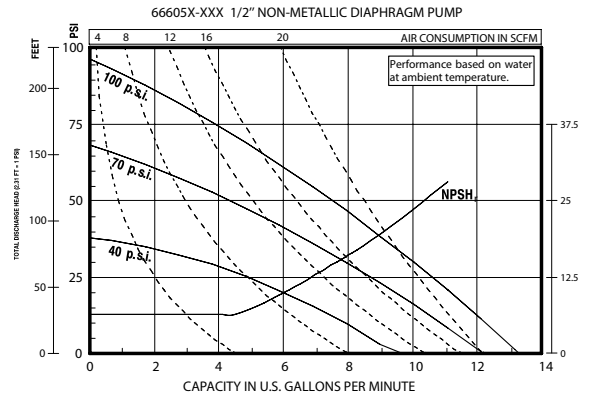

Refer to www.AROzone.com for full size flow curves.
For additional information contact
technical support at 1.800.495.0276

3/4" Non-Metallic Models

COMPACT SERIES PUMPS

Part of our Compact Series of pumps, our 3/4" pumps feature big performance in a small package. They offer flow rates up to 14.8 GPM (56 LPM) and a wide range of material and porting configurations.

UPGRADE
PUMP FOR REMOTE
ACTUATION CAPABILITY

| | |
|-----------------------------|---|
| Ratio: | 1:1 |
| Maximum Flow: | 14.8 g.p.m. (56 l.p.m.) |
| Displacement per cycle: | 0.032 Gallons (0.12 Liters) |
| Air Inlet: (Female) | 1/4 - 18 P.T.F. SAE Short |
| Fluid Inlet/Outlet: | 1/2 - 14 N.P.T.F. - 1 Rp 1/2 (1/2 -14 BSP, parallel) |
| Max. operating pressure: | 100 psi (6.9 bar) |
| Suspended solids max. dia.: | 3/32" (2.4 mm) |
| Weight: lbs (kg) | 5.61 (2.54) |
| Maximum dry suction lift: | ft (m) 15.0 (4.5) |
| Sound Level: | 70 PSI 60 Cycles/Min 75.0 db(A) |
| Muffler: | Integral, Included |



PD07P-BPS-PAA

Ordering

| Position | 1 | 2 | | 3 | 4 | 5 | | 6 | 7 | 8 | | 9 | 10 |
|----------|------|---|---|---|---|---|---|---|---|---|---|---|----|
| Example: | PD07 | P | - | X | X | S | - | X | X | X | - | X | X |

| Position 1 Model Series | Position 2 Center Section | Position 3 Connections | Position 4 Manifold Material | Position 5 Hardware | Position 6 Seat Material | Position 7 Ball Material | Position 8 Diaphragm Material | Position 9 and 10 |
|---|---------------------------------|---|------------------------------------|------------------------|--------------------------------|--|--|--|
| PD07 - Standard Pump PE07 - Remote Actuation Capable | P - Polypropylene | A - 14 - 3/4" N.P.T.F.-1 B - Rp 3/4 (3/41/2 -14 BSP, parallel) | P - Polypropylene (Single Port) | S - SS | P - Polypropylene | A - Santoprene® C - Hytrel® T - PTFE | A - Santoprene® C - Hytrel® L - Long-Life PTFE T - PTFE | Fluid control options for pump with electronic interface (PE07 model). See complete description on page 19 |

Accessories

Air Line Connection Kit | 66073-1
(Piggyback Filter/Regulator with gauge, pipe nipple and 5-foot air hose)

Cycle Counter Kit | 66975

Muffler Kit | 637438 (ported exhaust) 3/8" NPT

Service Repair Kits | 637428 (air section)
637427-XX (fluid section)

Wall Mount | 76763



Air Line Connection Kit
66073-1

3/4" Non-Metallic Dimensions and Flow Charts

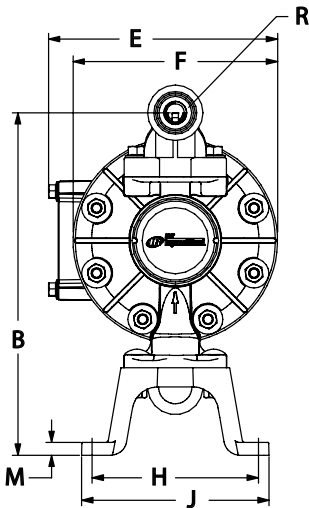
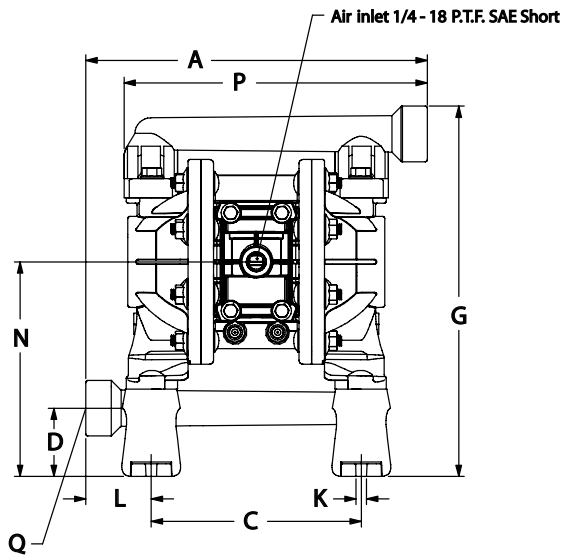

DIMENSIONS

| | | |
|------------------------|-------------------------|-----------------------|
| A - 10" (254.2 mm) | F - 6-1/32" (153.1mm) | L - 1-15/16" (48.9mm) |
| B - 10-3/32" (256.1mm) | G - 10-29/32" (276.8mm) | M - 3/8" (9.6mm) |
| C - 6-3/16" (157.1mm) | H - 4-29/32" (124.2 mm) | N - 6-5/16" (160.5mm) |
| D - 2" (51.0mm) | J - 5-17/32" (140.2mm) | P - 8-7/8" (225.3mm) |
| E - 6-3/4" (171.0mm) | K - 5/16" (8.0mm) | |

| | | |
|---------------|---------------------|---------------------|
| Model | "Q" Material Inlet | "R" Material Outlet |
| PD07P-APS-PXX | 3/4- 14N.P.T.F. - 1 | 3/4- 14N.P.T.F. - 1 |
| PD07P-BPS-PXX | Rp 3/4(3/4- 14BSP) | Rp 3/4(3/4- 14BSP) |

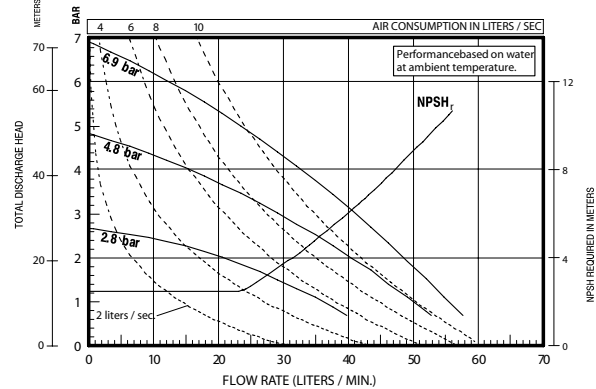
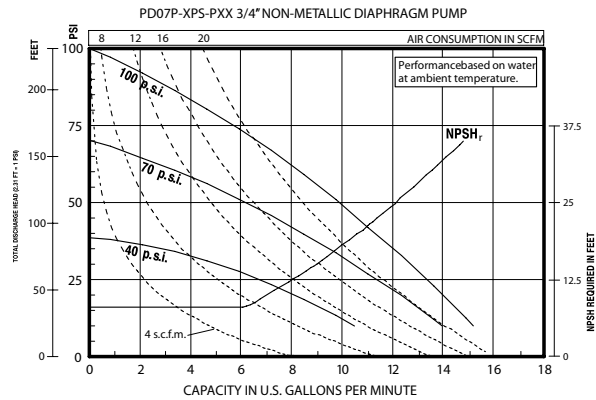

Refer to www.AROzone.com for full size flow curves.
For additional information contact
technical support at 1.800.495.0276

Ordering Position 9 Specialty Code 1 (Blank if no Specialty Code)

- A - Solenoid 120VAC
- B - Solenoid 12VDC
- C - Solenoid 240VAC
- D - Solenoid 24VDC
- N - Solenoid with no coil
- O - Standard Valve Block (No Solenoid)
- P - Ported Mortor (No major valve provided)

Ordering Position 10 Specialty Code 2 (Blank if no Specialty Code)

- E - End of stroke feedback + Leak Detection
- F - End of stroke feedback
- L - Leak Detection
- O - No Option

1" Non-Metallic Models

ARO® EXP 1" non-metallic diaphragm pumps are a versatile solution for numerous applications. Our EXP 1" models achieve flow rates of up to 53 GPM (200.6 LPM) and offer a wide array of material and porting configurations. These pumps are often used for transfer, filling, recirculation and supply in chemical, industrial and water/wastewater treatment markets.

| | |
|--|--|
| Ratio: | 1:1 |
| Maximum GPM (LPM): | 53 (200) |
| Displacement per cycle Gallons (Liters): | 0.226 (0.86) |
| Air Inlet (Female): | 1/4 - 18 N.P.T. |
| Fluid Inlet/Outlet: | 1 - 11-1/2 N.P.T.F., Rp1(1-11 BSP) 1" A.N.S.I./DIN flange (side or center) |
| Max. operating pressure psi (bar): | 120 (8.3) |
| Suspended solids max. dia. in.(mm): | 1/8" (3.2) |
| Weight lbs (kg): | Polypropylene, Threaded Port 19.35 (8.78) Polypropylene, Center Ported 19.59 (8.89) Polypropylene, Side Ported 19.87 (9.01) PVDF, Threaded Port 25.83 (11.72) PVDF, Center Ported 26.72 (12.12) PVDF, Side Ported 27.15 (12.32) |
| Maximum dry suction lift ft(m) : | 19 (5.7) |
| Sound Level: | 70 PSI 60 Cycles/Min 79.7 db(A) |
| Muffler Included: | 93110 |



Ordering

| Position | 1 | 2 | | 3 | 4 | 5 | | 6 | 7 | 8 | | 9 | 10 |
|----------|------|---|---|---|---|---|---|---|---|---|---|---|----|
| Example: | PX10 | X | - | X | X | S | - | X | X | X | - | X | X |

| Position 1 Model Series | Position 2 Center Section | Position 3 Connections | Position 4 Wetted Parts | Position 5 Hardware | Position 6 Seat Material | Position 7 Ball Material | Position 8 Diaphragm Material | Position 9 and 10 |
|---|---|---|--|------------------------|--|--|---|--|
| PD10 - Standard Pump PE10 - Electronic Interface Accessible Pump | E - Conductive Polypropylene P - Polypropylene | A - NPTF Thread B - BSP Thread F - 1" A.N.S.I./DIN Flange (Side) Y - 1" A.N.S.I./DIN Flange (Center) | E - Conductive Polypropylene* K - PVDF P - Polypropylene | S - SS | H - 440 SS (Hard) K - PVDF P - Polypropylene S - 316 SS | A - Santoprene® C - Hytrel® G - Nitrile T - PTFE V - Viton | A - Santoprene® C - Hytrel® G - Buna-N L - Long-Life PTFE M - Med. Grade Santoprene® T - PTFE/Santoprene® V - Viton | Fluid control options for pump with electronic interface (PE10 model). See complete description on page 21 |

* Acceptable for use in hazardous locations. - NEC / CEC: Class I&II, Div 1&2
- ATEX: Zone 1&2, 21&22

Accessories

Air Line Connection Kit | 66073-2
(Piggyback Filter/Regulator with gauge, pipe nipple and 5-foot air hose)

Diaphragm Failure Detection | 67237

ARO® Diaphragm Failure Detection is a simple, cost-effective way to get your pumps wired for preventive maintenance. (PE10X pump model is required)

Cycle Counter Kit | 66350

Cycle Sensor Kit | 67350

Service Repair Kits | 637397 (air motor for PX10P), 637396-XX (fluid section), 637395-X (major air valve assembly)

Flange Connection Kits | 67341-E10N (side flange), 67341-C10N (center flange)
Use with non-metallic EXP pumps with the flange manifold option



Flange Connection Kit

1" Non-Metallic Dimensions and Flow Charts

1 - 11-1/2 N.P.T.F. - 1 (PX10P-AXS-XXX)
Rp 1 - 11 BS (PX10P-BXS-XXX)

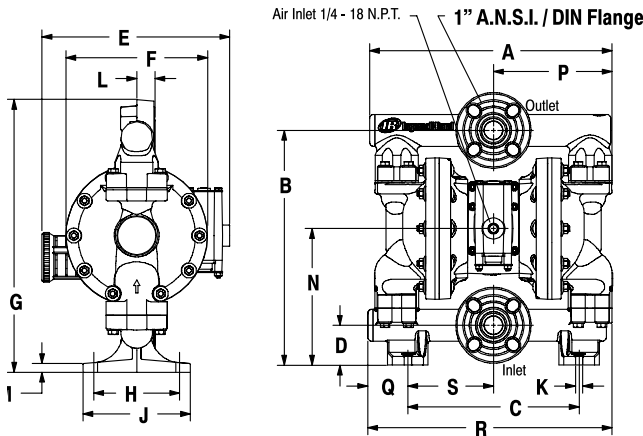
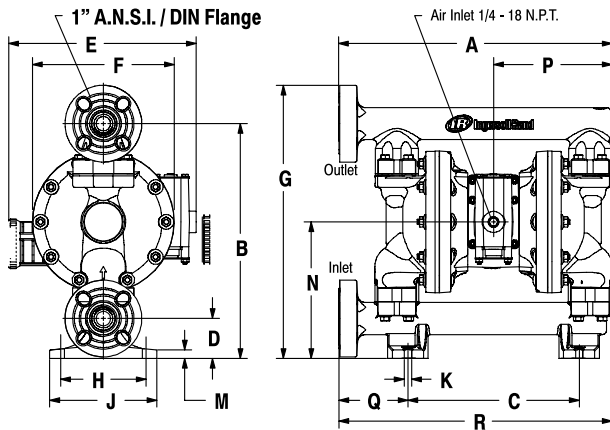
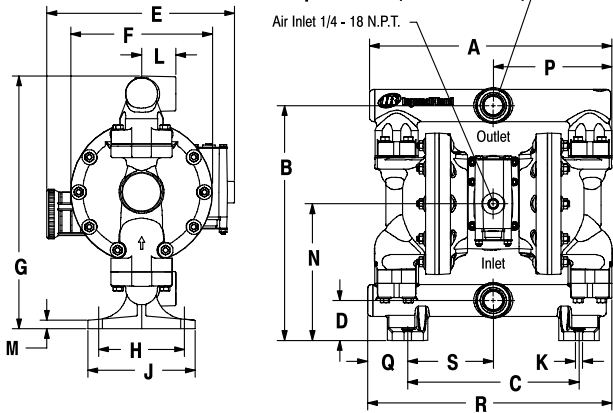

DIMENSIONS

| | | |
|---------------------------------|-------------------------------|----------------------------------|
| A - see below | G - see below | N - 8-1/32" (203.4 mm) |
| B - 13-25/32" (349.8 mm) | H - 5-1/32" (127.6 mm) | P - 6-31/32" (176.6 mm) |
| C - 10-1/16" (255.3 mm) | J - 6-9/32" (159.6 mm) | Q - see below |
| D - 2-11/32" (59.4 mm) | K - 7/16" (11.1 mm) | R - see below |
| E - 11-1/32" (279.5 mm) | L - see below | S - 5-1/32" (127.6 mm) |
| F - 8-5/16" (211.1 mm) | M - 1/2" (12.7 mm) | |
| PX10P-AXS-, -BXS- (Threaded) | PX10P-EXS-XXX (End Flange) | PX10P-YXS-XXX (Center Flange) |
| A - 14-7/32" (361.2 mm) | 16-1/32" (407.3 mm) | 14-7/32" (361.2 mm) |
| G - 14-27/32" (376.5 mm) | 16-1/32" (407.3 mm) | 16" (406.3 mm) |
| L - 2" (50.8 mm) | ----- | 1-1/32" (25.6 mm) |
| Q - 2-3/8" (59.7 mm) | 4-1/16" (103.0 mm) | 2-3/8" (59.7 mm) |
| R - 14-11/32" (364.0 mm) | 16-1/32" (407.3 mm) | 14-11/32" (364.0 mm) |

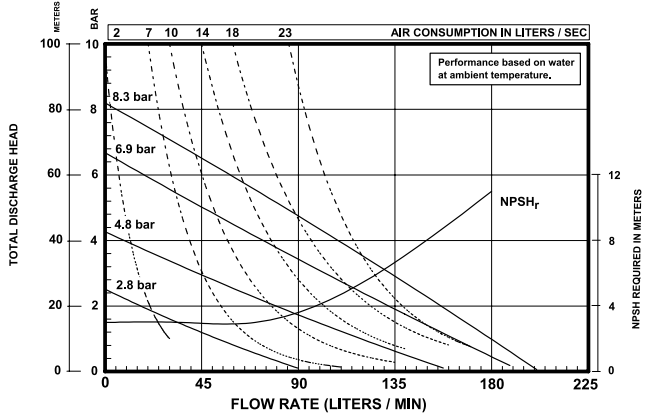
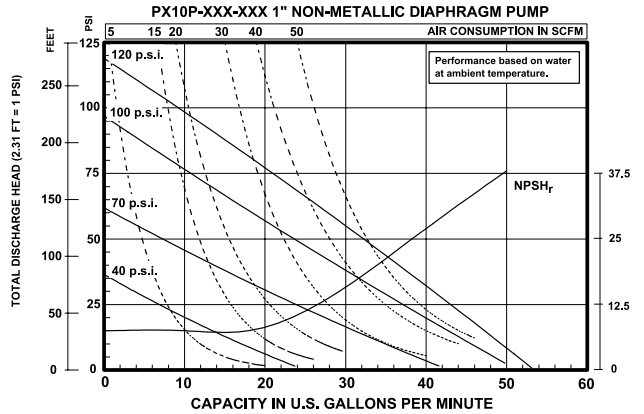

Refer to www.AROzone.com for full size flow curves.
For additional information contact
technical support at 1.800.495.0276

Ordering Position 10

Specialty Code 1 (Blank if no Specialty Code)

| | |
|---------------------|---|
| A - Solenoid 120VAC | G - Solenoid 12VDC ATEX/IECex* |
| B - Solenoid 12VDC | H - Solenoid 24VDC ATEX/IECex* |
| C - Solenoid 240VAC | J - 120VAC NEC/CEC* |
| D - Solenoid 24VDC | K - Solenoid 220VAC ATEX/IECex* |
| E - 12vDC NEC/CEC* | N - Solenoid with no coil |
| F - 24vDC NEC/CEC* | O - Standard Valve Block (No Solenoid) |
| | P - Ported Mortor (No major valve provided) |

Ordering Position 11

Specialty Code 2 (Blank if no Specialty Code)

| | |
|--|--|
| E - End of stroke feedback + Leak Detection | L - Leak Detection |
| F - End of stroke feedback | M - Leak Detection ATEX/IECex/NEC/CEC* |
| G - End of Stroke ATEX/IECex* | O - No Option |
| H - End of Stroke/Leak Detection ATEX/IECex* | R - End of Stroke Feedback NEC / CEC* |
| | T - End of Stroke Feedback + Leak Detection NEC / CEC* |

* Acceptable for use in hazardous locations. - NEC / CEC: Class I&II, Div 1&2
- ATEX: Zone 1&2, 21&22

1-1/2" Non-Metallic Models

ARO® 1-1/2" non-metallic diaphragm pumps are frequently used in transfer, filling, recirculation and supply in chemical, industrial and water/wastewater treatment markets. Our 1-1/2" models achieve flow rates of up to 123.1 GPM (465.9 LPM) and also offer a diverse selection of material and porting configurations.

UPGRADE
PUMP FOR REMOTE
ACTUATION CAPABILITY

| | | | |
|--|---|-----------------|------------|
| Ratio: | 1:1 | | |
| Maximum GPM (LPM): | 123 (465) | | |
| Displacement per cycle Gallons (Liters): | 0.617 (2.34) | | |
| Air Inlet (Female): | 1/2 - 14 N.P.T. | | |
| Fluid Inlet/Outlet: | 1-1/2" A.N.S.I./DIN flange (side or center) | | |
| Max. operating pressure psi (bar): | 120 (8.3) | | |
| Suspended solids max. dia. in. (mm): | 1/4" (6.4) | | |
| Weight lbs (kg): | Polypropylene, Side Ported | 42.6 (19.3) | |
| | PVDF, Side Ported | 63.9 (29) | |
| | Polypropylene, Center Ported | 42.3 (19.2) | |
| | PVDF, Center Ported | 55.9 (25.3) | |
| Maximum dry suction lift ft (m) : | 14 (4.2) | | |
| Sound Level: | 70 PSI | 60 Cycles / Min | 81.0 db(A) |
| Muffler Included: | 93139 | | |



Ordering

| Position | 1 | 2 | | 3 | 4 | 5 | | 6 | 7 | 8 | | 9 | 10 |
|-----------------|-------------|----------|----------|----------|----------|----------|----------|----------|----------|----------|----------|----------|----------|
| Example: | PX15 | X | - | X | X | S | - | X | X | X | - | X | X |

| Position 1 Model Series | Position 2 Center Section | Position 3 Connections | Position 4 Wetted Parts | Position 5 Hardware | Position 6 Seat Material | Position 7 Ball Material | Position 8 Diaphragm Material | Position 9 and 10 |
|---|---|--|--|------------------------|--|--|---|--|
| PD15 - Standard Pump PE15 - Electronic Interface Accessible Pump | E - Conductive Polypropylene P - Polypropylene | F - 1-1/2" A.N.S.I./DIN Flange (Side) Y - 1-1/2" A.N.S.I./DIN Flange (Center) | E - Conductive Polypropylene* K - PVDF P - Polypropylene | S - SS | H - 440 SS (Hard) K - PVDF P - Polypropylene S - 316 SS | A - Santoprene® C - Hytrel® G - Nitrile S - 316 SS T - PTFE V - Viton | A - Santoprene® C - Hytrel G - Buna-N L - Long-Life PTFE M - Medical Grade Santoprene® T - PTFE/Santoprene® V - Viton | Fluid control options for pump with electronic interface (PE15 model). See complete description on page 23 |

* Acceptable for use in hazardous locations. - NEC / CEC: Class I&II, Div 1&2
- ATEX: Zone 1&2, 21&22

Accessories

Air Line Connection Kit | 66084-1

(Piggyback Filter/Regulator with gauge, pipe nipple and 5-foot air hose)

Diaphragm Failure Detection | 67237

Cycle Counter Kit | Cycle Counter Kit| 66350

Service Repair Kits | 637389 (air motor for PX15P), 637391-XX (fluid section)
637390-X (major air valve assembly)

Flange Connection Kit | 67341-E15N (side flange), 67341-C15N (center flange)

Use with non-metallic EXP pumps with the flange manifold option



Flange Connection Kit

1-1/2" Non-Metallic Dimensions and Flow Charts

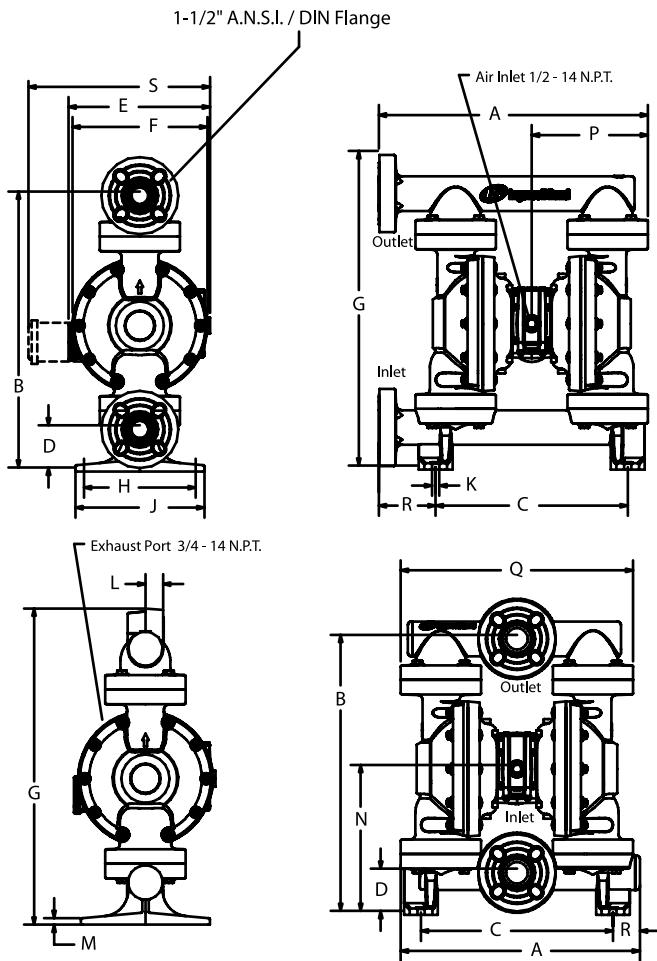

- A - see below
- B - 21-15/32" (545.3 mm)
- C - 14-15/16" (379.4 mm)
- D - 3-9/32" (83.3 mm)
- E - see below
- F - 10-1/2" (266.3 mm)
- G - see below
- H - 8-11/16" (220.7 mm)
- J - 10-1/32" (254.8 mm)
- K - 9/16" (14.3 mm)
- L - see below
- M - 17/32" (13.0 mm)
- N - 11-3/8" (288.4 mm)
- P - 9-1/32" (229.5 mm)
- Q - see below
- R - see below
- S - see below

- PX15P-EXS-XXX
(End Flange)
- A - 20-15/16" (531.6 mm)
 - G - 24-15/32" (621.5 mm)
 - L - -----
 - Q - -----
 - R - 4-7/16" (112.4 mm)

- PX15P-YXS-XXX
(Center Flange)
- A - 18-19/32" (472.3 mm)
 - G - 24-19/32" (624.5 mm)
 - L - 1-3/8" (34.9 mm)
 - Q - 18-3/32" (459.0 mm)
 - R - 2-3/32" (53.1 mm)

- PX15E-XXX-XXX "E" "S" 14-1/8" (358.5 mm)
- PX15P-XXX-XXX 11" (279.5 mm) -----

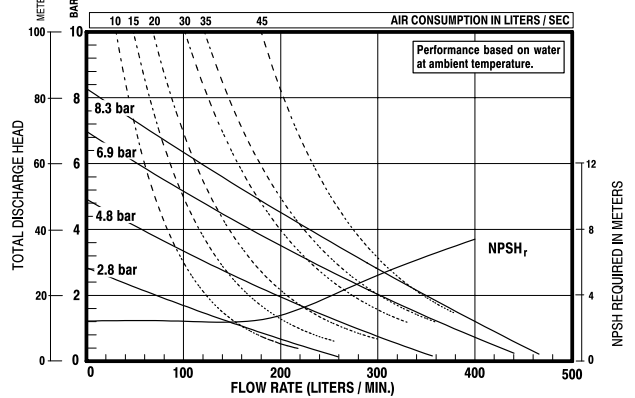
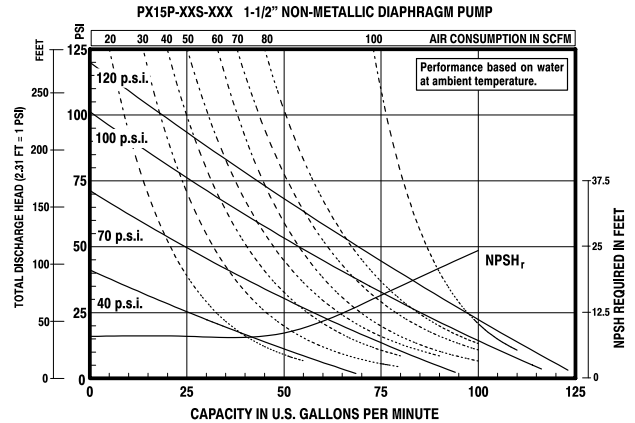

Refer to www.AROzone.com for full size flow curves.
For additional information contact
technical support at 1.800.495.0276

Ordering Position 10

Specialty Code 1 (Blank if no Specialty Code)

- A - Solenoid 120VAC
- B - Solenoid 12VDC
- C - Solenoid 240VAC
- D - Solenoid 24VDC
- E - 12vDC NEC/CEC*
- F - 24vDC NEC/CEC*
- G - Solenoid 12VDC ATEX/IECex*
- H - Solenoid 24VDC ATEX/IECex*
- J - 120VAC NEC/CEC*
- K - Solenoid 220VAC ATEX/IECex*
- N - Solenoid with no coil
- O - Standard Valve Block (No Solenoid)
- P - Ported Mortor (No major valve provided)

Ordering Position 11

Specialty Code 2 (Blank if no Specialty Code)

- E - End of stroke feedback + Leak Detection
- F - End of stroke feedback
- G - End of Stroke ATEX/IECex*
- H - End of Stroke/Leak Detection ATEX/IECex*
- L - Leak Detection
- M - Leak Detection ATEX/IECex/NEC/CEC*
- O - No Option
- R - End of Stroke Feedback NEC / CEC*
- T - End of Stroke Feedback + Leak Detection NEC / CEC*

* Acceptable for use in hazardous locations. - NEC / CEC: Class I&II, Div 1&2
- ATEX: Zone 1&2, 21&22

2" Non-Metallic Models

ARO EXP 2" non-metallic pumps achieve flow rates of up to 184 GPM (696.4 LPM) and offer a wide array of material and porting configurations. 2" non-metallic pumps are often used for transfer, filling, recirculation and batching in Chemical, Industrial and Water/Wastewater treatment markets.

UPGRADE
PUMP FOR REMOTE
ACTUATION CAPABILITY

| | |
|--|--|
| Ratio: | 1:1 |
| Maximum GPM (LPM): | 184 (696) |
| Displacement per cycle Gallons (Liters): | 1.4 (5.3) |
| Air Inlet (Female): | 3/4 - 14 N.P.T. |
| Fluid Inlet/Outlet: | 2" A.N.S.I./DIN flange (side) |
| Max. operating pressure psi (bar): | 120 (8.3) |
| Suspended solids max. dia. in. (mm): | 1/4" (6.4) |
| Weight lbs (kg): | Polypropylene 85.3 (38.7) PVDF 110.9 (50.3) |
| Maximum dry suction lift ft (m): | 14 (4.2) |
| Sound Level: | 70 PSI 60 Cycles/Min 85.0 db(A) |
| Muffler Included: | 93139 |



Ordering

| Position | 1 | 2 | | 3 | 4 | 5 | | 6 | 7 | 8 | | 9 | | 10 | 11 |
|----------|------|---|---|---|---|---|---|---|---|---|---|---|---|----|----|
| Example: | PX20 | X | - | F | X | S | - | X | X | X | - | B | - | X | X |

| Position 1 Model Series | Position 2 Center Section | Position 3 Connections | Position 4 Wetted Parts | Position 5 Hardware | Position 6 Seat Material | Position 7 Ball Material | Position 8 Diaphragm Material | Position 9 |
|---|---|-----------------------------------|--|------------------------|-------------------------------|--|--|--|
| PD20 - Standard Pump PE20 - Electronic Interface Accessible Pump | E - Conductive Polypropylene P - Polypropylene | F - 2" A.N.S.I./DIN Flange (Side) | E - Conductive Polypropylene* K - PVDF P - Polypropylene | S - SS | K - PVDF P - Polypropylene | A - Santoprene® C - Hytrel® G - Nitrile T - PTFE V - Viton | A - Santoprene® C - Hytrel® G - Buna-N L - Long-Life PTFE M - Medical Grade Santoprene® T - PTFE/Santoprene® V - Viton | Revision Level Position 10 & 11 Specialty Code Fluid control options for pump with electronic interface (PE20 model). See complete description on page 25 |

* Acceptable for use in hazardous locations. - NEC / CEC: Class I&II, Div 1&2
- ATEX: Zone 1&2, 21&22

Accessories

Air Line Connection Kit | 66109

(Piggyback Filter/Regulator with gauge, pipe nipple and 5-foot air hose)

Diaphragm Failure Detection | Kit No.67237

Cycle Counter Kit | 66350

Cycle Sensor Kit | 67350-1 (PE20X pump model is required)

Service Repair Kits | 637369 (air motor for PX20P), 637373-XX (fluid section), 637374-X (major air valve assembly)

Continuous-Duty Muffler | 67323 Recommended for continuous-duty and high-flow applications.

Muffler features large expansion chamber, permitting cold exhaust air to exit pump

Flange Connection Kit | 67341-E20N



67323
Continuous Duty
Muffler

2" Non-Metallic Dimensions and Flow Charts

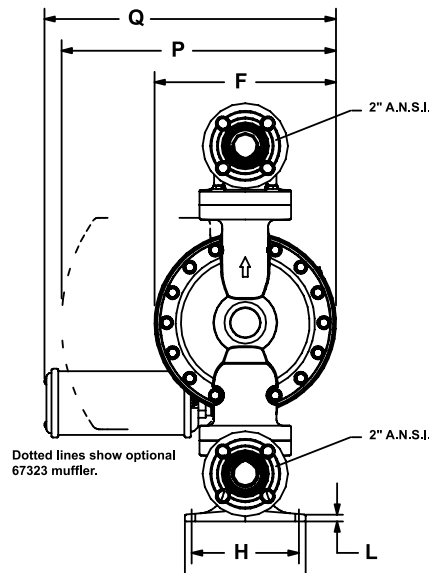
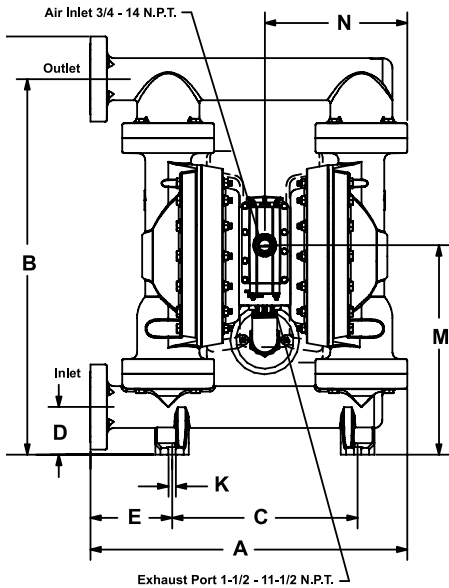

- | | |
|-------------------------|-------------------------|
| A - 24-3/16" (614.3mm) | F - 13-7/8" (352.0mm) |
| B - 28-21/32" (728.0mm) | G - 31-29/32" (810.5mm) |
| C - 14-5/32" (360.0mm) | H - 8-3/16" (207.8mm) |
| D - 3-5/8" (92.2mm) | J - 9-7/32" (234.2mm) |
| E - 6-1/4" (158.3mm) | K - 9/16" (14.3mm) |
| L - 1/2" (12.7mm) | |
| M - 16" (405.9mm) | |
| N - 10-7/8" (276.2mm) | |
| P - 20-31/32" (532.2mm) | |
| Q - 22-9/32" (565.5mm) | |

PX20P-FXS-XXX 2" NON-METALLIC DIAPHRAGM PUMP

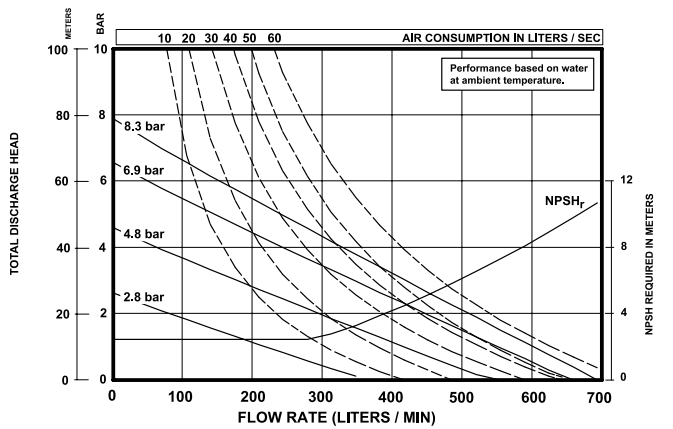
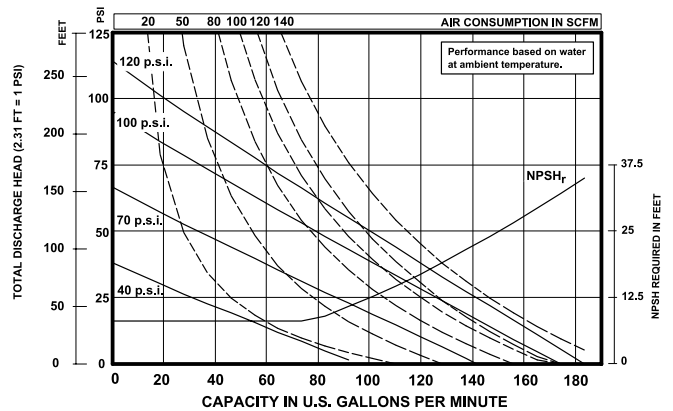

Refer to www.AROzone.com for full size flow curves.
For additional information contact
technical support at 1.800.495.0276

Ordering Position 10

Specialty Code 1 (Blank if no Specialty Code)

- | | |
|---------------------|---|
| A - Solenoid 120VAC | G - Solenoid 12VDC ATEX/IECex* |
| B - Solenoid 12VDC | H - Solenoid 24VDC ATEX/IECex* |
| C - Solenoid 240VAC | J - 120VAC NEC/CEC* |
| D - Solenoid 24VDC | K - Solenoid 220VAC ATEX/IECex* |
| E - 12vDC NEC/CEC* | N - Solenoid with no coil |
| F - 24vDC NEC/CEC* | O - Standard Valve Block (No Solenoid) |
| | P - Ported Mortor (No major valve provided) |

Ordering Position 11

Specialty Code 2 (Blank if no Specialty Code)

- | | |
|--|--|
| E - End of stroke feedback + Leak Detection | L - Leak Detection |
| F - End of stroke feedback | M - Leak Detection ATEX/IECex/NEC/CEC* |
| G - End of Stroke ATEX/IECex* | O - No Option |
| H - End of Stroke/Leak Detection ATEX/IECex* | R - End of Stroke Feedback NEC / CEC* |
| | T - End of Stroke Feedback + Leak Detection NEC / CEC* |

* Acceptable for use in hazardous locations. - NEC / CEC: Class I&II, Div 1&2
- ATEX: Zone 1&2, 21&22

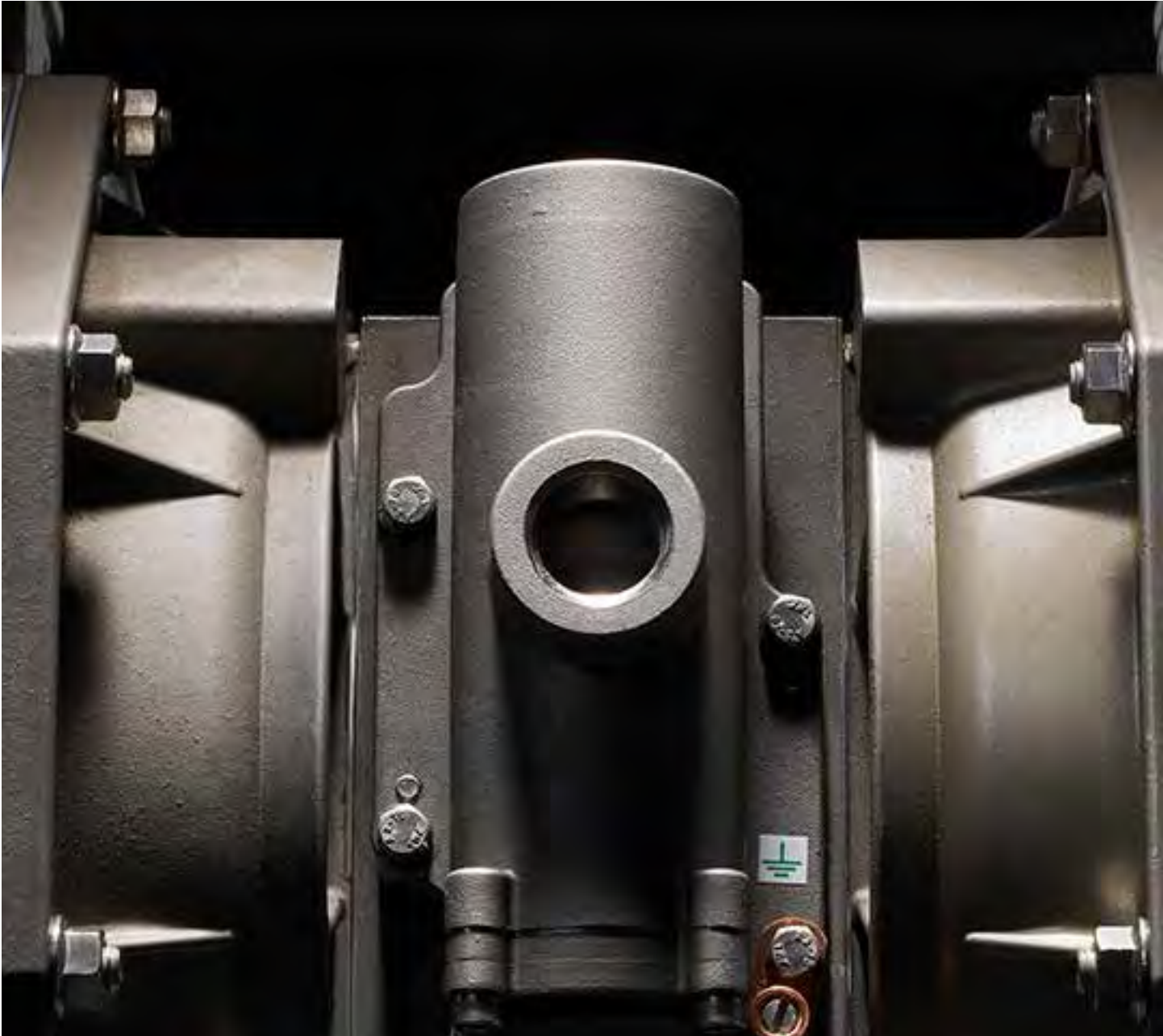

Metallic Models

The ARO® range of diaphragm pumps offers many materials of construction compatible for the chemical industry: Our metallic offering consists of aluminium, cast iron, stainless steel and hastelloy.

Metallic Model Overview

All 1/2" - 3" Metallic PD pumps are now upgradeable!

PD pumps are manufactured such that solenoid operation, flow monitoring and leak detection functionality can be added at a later date. As your processes mature, this capability allows you to enhance manually operated processes to incorporate additional control and monitoring capabilities. Simply remove two plugs and replace with a proximity sensor and (or) leak detector. Call ARO® Technical Service to learn more. Once upgraded, these components can also be integrated with the ARO® controller for seamless integration.

UPGRADE
PUMP FOR REMOTE
ACTUATION CAPABILITY

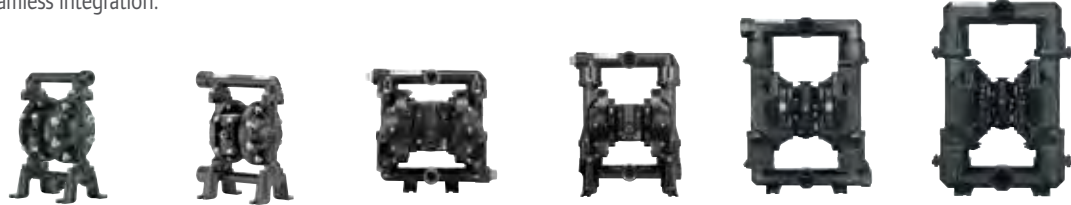

| Models | 1/2" Metallic | 3/4" Metallic | 1" Metallic | 1-1/2" Metallic | 2" Metallic | 3" Metallic |
|--------------------------------------|---|--|---|---|--|--|
| Maximum Flow gpm (lpm) | 12 (45.4) | 13.6 (51.5) | 52 (197) | 123 (465) | 172 (651) | 275 (1,041) |
| Maximum Discharge Pressure psi (bar) | 100 (6.9) | 100 (6.9) | 120 (8.3) | 120 (8.3) | 120 (8.3) | 120 (8.3) |
| Fluid Ports Inlet/Outlet (bsp) | 1/2" (F) - In/Out | 3/4 - 14 N.P.T.F.-2 Rp 3/4(3/4-14BSP, parallel) | 1-11-1/2" NPT Rp1(1-11 BSP) (Side or Center) | 1-1/2 - 11-1/2 NPTF Rp1-1/2(1-1/2 -11 BSP) (Side or Center) 1-1/2 ANSI/DIN (SS only/Center) | 2" NPTF Rp2 (2-11 BSP) (Side or Center) 2" ANSI/DIN Flange with 2" pipe tap (SS only/Center) | 3" NPTF Rp3(3-11 BSP) (Center) 3" ANSI/DIN Flange |
| Material of Construction | Aluminum Stainless Steel | Aluminum | Aluminum Cast Iron Stainless Steel Hastelloy® | Aluminum Cast Iron Stainless Steel Hastelloy® | Aluminum Cast Iron Stainless Steel Hastelloy® | Aluminum Cast Iron Stainless Steel Hastelloy® |
| Pump Weight lbs (kg) | 10.4 (4.7) PD05A-XAS-X-B 16.6 (7.5) PD05A-XSS-X-B 8.0 (3.7) PD05R-XAS-X-B 14.3 (6.5) PD05R-XSS-X-B | 8.74 (3.96) | 20.7 (9.4) Alum 35.2 (16.0) CI 38.2 (17.3) SS 39.6 (18.0) Hastelloy add 4.65 (2.11) for Alum. air motor, add 11.09 (5.03) for SS air motor | 37.7 (17.1) Alum. 73.2 (33.2) CI 61.2 (27.8) SS 86.9 (39.4) Hastelloy add 3.08 (1.40) for Alum. air motor, add 14.39 (6.53) for SS air motor | 64 (29) Alum. 133 (60) CI 122 (55.3) SS Threaded 114 (51.7) SS Flange 122 (55.3) Hastelloy add 34 (15) for CI or SS air motor | 113 (51.3) Alum. 197 (89.4) CI 203 (92.1) SS 203 (92.1) Hastelloy add 40 (18.1) for SS air motor |
| Maximum Solids in (mm) | 3/32 (2.4) | 3/32 (2.4) | 1/8 (3.32) | 1/4 (6.4) | 1/4 (6.4) | 3/8 (9.5) |
| Maximum Dry Suction Lift ft (m) | 15 (4.5) | 15 (4.5) | 19 (5.7) | 14 (4.2) | 14 (4.2) | 14 (4.2) |
| Recommended Filter/Regulator | P39124-624 | P39124-624 | P39224-614 | P39344-614 | P39354-614 | P39454-614 |
| Airline Kit | 66073-1 | 66073-1 | 66073-2 | 66084-1 | 66109 | 66109 |

1/2" Metallic Models

COMPACT SERIES PUMPS

Part of our Compact Series of pumps, our 1/2" metallic pumps feature big performance in a small package. They achieve flow rates up to 14.4 GPM (54.5 LPM) and offer a wide range of material and porting configurations.

UPGRADE
PUMP FOR REMOTE
ACTUATION CAPABILITY

| | | |
|----------------------------------|--|------------|
| Ratio: | 1:1 | |
| Maximum Flow: | 12.0 g.p.m. (45.4 l.p.m.) | |
| Displacement per cycle: | 0.039 Gallons (0.15 Liters) | |
| Air Inlet: (Female) | 1/4 - 18 P.T.F. SAE Short (PD05R-X-X-B models) 1/4 - 18 N.P.T.F. - 1 (PD05A-X-X-B models) | |
| Fluid Inlet/Outlet: | 1/2 - 14 N.P.T.F. - 1 Rp 1/2 (1/2 - 14 BSP, parallel) | |
| Max. operating pressure: | 100-psi (6.9-bar) | |
| Suspended solids max. dia.: | 3/32-in. (2.4-mm) | |
| Weight: lbs (kg) | PD05A-XAS-XXX-B | 10.4 (4.7) |
| | PD05A-XSS-XXX-B | 16.6 (7.5) |
| | PD05R-XAS-XXX-B | 8.0 (3.7) |
| | PD05R-XSS-XXX-B | 14.3 (6.5) |
| Maximum dry suction lift: ft (m) | 15 (4.5) | |
| Sound Level: | 70 PSI 60 Cycles/Min 75 db(A) | |
| Muffler: | PD05A - 93110; PD05R - Integral | |



Ordering

| Position | 1 | 2 | | 3 | 4 | 5 | | 6 | 7 | 8 | | 9 | | 10 | 11 |
|----------|------|---|---|---|---|---|---|---|---|---|---|---|---|----|----|
| Example: | PX05 | X | - | X | X | S | - | X | X | X | - | B | - | X | X |

| Position 1 Model Series | Position 2 Center Section | Position 3 Connections | Position 4 Wetted Parts | Position 5 Hardware | Position 6 Seat Material | Position 7 Ball Material | Position 8 Diaphragm Material | Position 9 |
|--|--|--|--|------------------------|--|--|---|---|
| D - Standard E - Remote Actuation Capable | A - Aluminum R - Poly- propylene | A - 1/2 - 14 N.P.T.F. - 1 B - Rp 1/2 (1/2 - 14 BSP, parallel) | A - Aluminum* S - Stainless Steel* | S - Stainless Steel | F - Aluminum P - Poly- propylene S - Stainless Steel | A - Santoprene® C - Hytrel® G - Nitrile S - Stainless Steel T - PTFE U - Polyurethane V - Viton | A - Santoprene® C - Hytrel® G - Nitrile L - Long-Life PTFE T - PTFE/ Santoprene® U - Polyurethane V - Viton | Revision Level Position 10 & 11 Specialty Code Fluid control options for pump with electronic interface (PE05 model). See complete description on page 29 |

* Acceptable for use in hazardous locations. - NEC / CEC: Class I&II, Div 1&2
- ATEX: Zone 1&2, 21&22

Accessories

Air Line Connection Kit | 66073-1

(Piggyback Filter/Regulator with gauge, pipe nipple and 5-foot air hose)

Cycle Counter Kit | 66975

Wall Mount Bracket Kit | 76763

Optional Muffler | 93110 used with 637438 kit

Service Repair Kits | 637428 (air section)

637427-XX (fluid section)

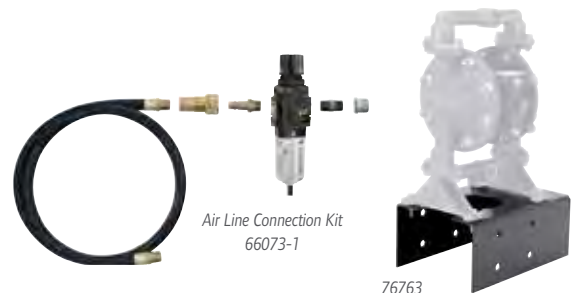

1/2" Metallic Dimensions and Flow Charts

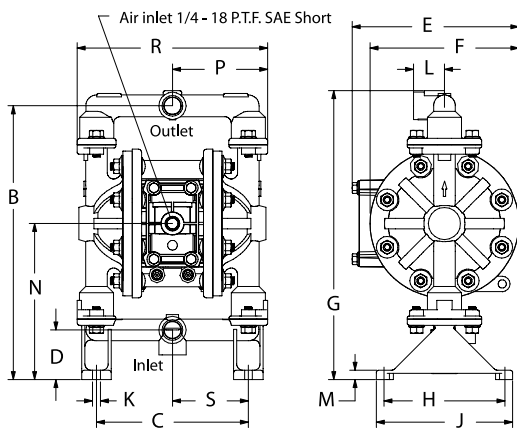
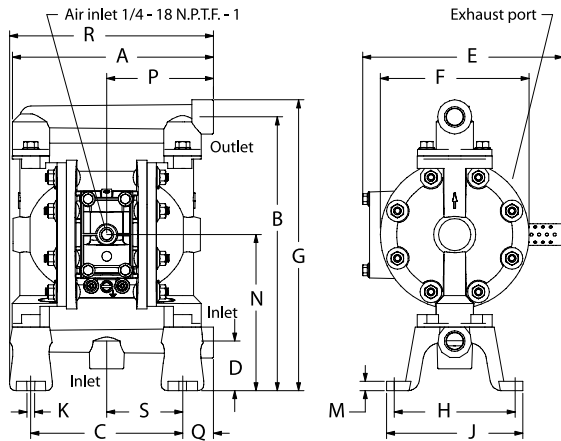

DIMENSIONS

| | | |
|-----------------------|---------------------|----------------------|
| A 8-1/8" (206.0 mm) | G see below | N 6-5/16" (159.9 mm) |
| B 11-1/16" (280.4 mm) | H 4-7/8" (123.8 mm) | P see below |
| C 6-1/8" (155.6 mm) | J 5-1/2" (139.7 mm) | Q 1-1/4" (31.6 mm) |
| D 2" (50.8 mm) | K 5/16" (8.0 mm) | R see below |
| E see below | L 1-1/4" (31.8 mm) | S 3-1/16" (77.8 mm) |
| F 6" (152.4 mm) | M 3/8" (9.5 mm) | |

| Dimension | PD05A-XXS-XXX-B | PD05R-XXS-XXX-B |
|-----------|--------------------|----------------------|
| "E" | 8-3/32" (205.5 mm) | 6-23/32" (170.6 mm) |
| "G" | 11-3/4" (297.9 mm) | 11-21/32" (296.0 mm) |
| "P" | 4-5/16" (109.3 mm) | 3-27/32" (97.4 mm) |
| "R" | 8-7/32" (208.5 mm) | 7-11/16" (194.9 mm) |

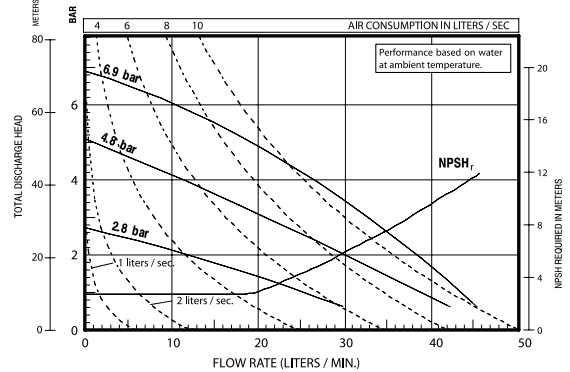
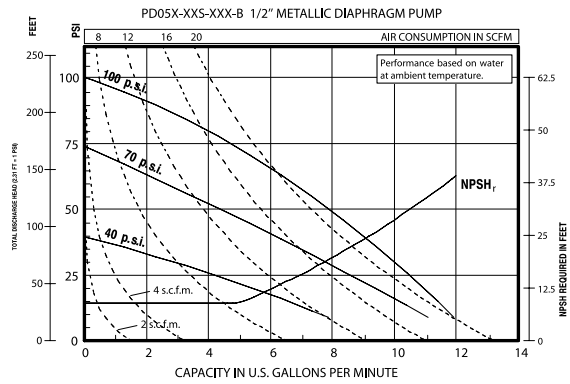

Refer to www.AROzone.com for full size flow curves.
For additional information contact
technical support at 1.800.495.0276

Ordering Position 10

Specialty Code 1 (Blank if no Specialty Code)

| | |
|---------------------|---|
| A - Solenoid 120VAC | G - Solenoid 12VDC ATEX/IECex* |
| B - Solenoid 12VDC | H - Solenoid 24VDC ATEX/IECex* |
| C - Solenoid 240VAC | J - 120VAC NEC/CEC* |
| D - Solenoid 24VDC | K - Solenoid 220VAC ATEX/IECex* |
| E - 12vDC NEC/CEC* | N - Solenoid with no coil |
| F - 24vDC NEC/CEC* | O - Standard Valve Block (No Solenoid) |
| | P - Ported Mortor (No major valve provided) |

Ordering Position 11

Specialty Code 2 (Blank if no Specialty Code)

| | |
|--|--|
| E - End of stroke feedback + Leak Detection | L - Leak Detection |
| F - End of stroke feedback | M - Leak Detection ATEX/IECex/NEC/CEC* |
| G - End of Stroke ATEX/IECex* | O - No Option |
| H - End of Stroke/Leak Detection ATEX/IECex* | R - End of Stroke Feedback NEC / CEC* |
| | T - End of Stroke Feedback + Leak Detection NEC / CEC* |

* Acceptable for use in hazardous locations. - NEC / CEC: Class I&II, Div 1&2
- ATEX: Zone 1&2, 21&22

3/4" Metallic Models

COMPACT SERIES PUMPS

Part of our Compact Series of pumps our 3/4" metallic pumps feature big performance in a small package. They achieve flow rates up to 14.8 GPM (56 LPM) and offer a wide range of material and porting configurations.

UPGRADE
PUMP FOR REMOTE
ACTUATION CAPABILITY

| | |
|----------------------------------|---|
| Ratio: | 1:1 |
| Maximum Flow: | 13.6-g.p.m. (51.5-l.p.m.) |
| Displacement per cycle: | 0.030-Gallons (0.11-Liters) |
| Air Inlet: (Female) | 1/4 - 18 P.T.F. SAE Short |
| Fluid Inlet/Outlet: | 3/4 - 14 N.P.T.F.-2 Rp 3/4 (3/4 -14 BSP, parallel) |
| Max. operating pressure: | 100-psi (6.9-bar) |
| Suspended solids max. dia.: | 3/32" (2.4-mm) |
| Weight: lbs (kg) | PX07R 8.74 (3.96) PX07A 11.0 (4.99) |
| Maximum dry suction lift: ft (m) | 15 (4.5) |
| Sound Level: | 70 PSI 60 Cycles/Min 75 db(A) |



PD07R-BAS-FAA

Ordering

| Position | 1 | 2 | | 3 | 4 | 5 | | 6 | 7 | 8 | | 9 | 10 |
|----------|------|---|---|---|---|---|---|---|---|---|---|---|----|
| Example: | PX07 | R | - | X | X | S | - | X | X | X | - | X | X |

| Position 1 Model Series | Position 2 Center Section | Position 3 Connections | Position 4 Wetted Parts | Position 5 Hardware | Position 6 Seat Material | Position 7 Ball Material | Position 8 Diaphragm Material | Position 9 and 10 |
|---|-----------------------------------|---|-------------------------------|------------------------|-----------------------------------|--|--|--|
| D - Standard Pump E - Remote Actuation Capable | A - Aluminum R - Polypropylene | A - 3/4 - 14 N.P.T.F.-2 B - Rp 3/4 (3/4 -14 BSP, parallel) | A - Aluminum* | S - SS | F - Aluminum P - Polypropylene | A - Santoprene® C - Hytrel® T - PTFE | A - Santoprene® C - Hytrel® L - Long-Life PTFE T - PTFE | Fluid control options for pump with electronic interface (PE07 model). See complete description on page 31 |

* Acceptable for use in hazardous locations. - NEC / CEC: Class I&II, Div 1&2
- ATEX: Zone 1&2, 21&22

Accessories

Air Line Connection Kit | 66073-1

(Piggyback Filter/Regulator with gauge, pipe nipple and 5-foot air hose)

Cycle Counter Kit | 66975

Wall Mount Bracket Kit | 76763

Optional Muffler | 93110 used with 637438 kit

Service Repair Kits | 637428 (air section)

637427-XX (fluid section)



Air Line Connection Kit
66073-1

3/4" Metallic Dimensions and Flow Charts

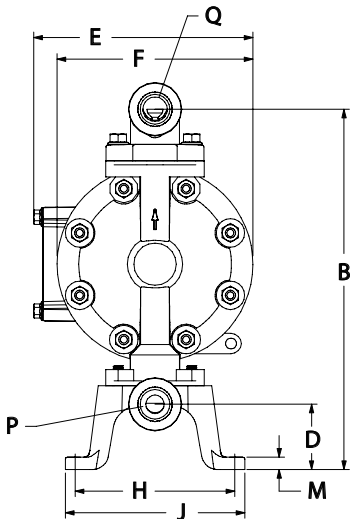
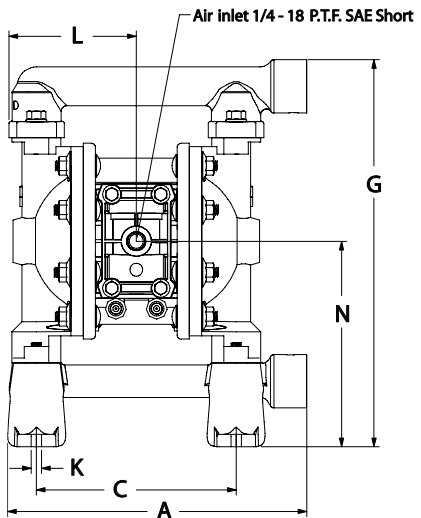

DIMENSIONS

| | | |
|------------------------|-------------------------|-----------------------|
| A - 9-9/32" (235.3mm) | F - 6" (152.4 mm) | L - 3-29/32" (99.2mm) |
| B - 11-1/16" (280.4mm) | G - 11-7/8" (301.2 mm) | M - 3/8" (9.5mm) |
| C - 6-1/8" (155.6mm) | H - 4-29/32" (124.2 mm) | N - 6-5/16" (159.8mm) |
| D - 2" (50.8mm) | J - 5-1/2" (139.7mm) | |
| E - 6-23/32" (170.6mm) | K - 5/16" (8.0 mm) | |

| | | |
|---------------|---------------------|---------------------|
| Model | "P" Material Inlet | "Q" Material Outlet |
| PD07R-AAS-PXX | 3/4- 14N.P.T.F. - 2 | 3/4- 14N.P.T.F. - 2 |
| PD07R-BAS-PXX | Rp 3/4(3/4- 14BSP) | Rp 3/4(3/4- 14BSP) |

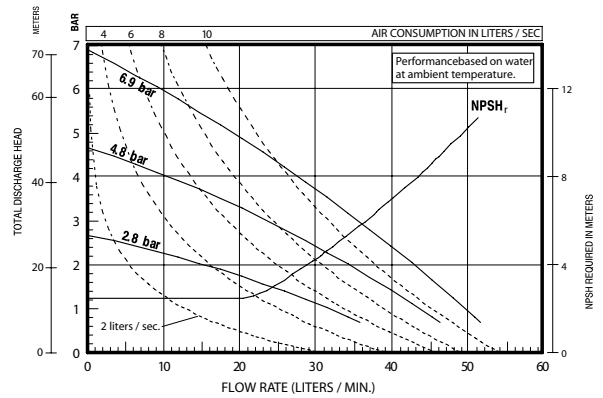
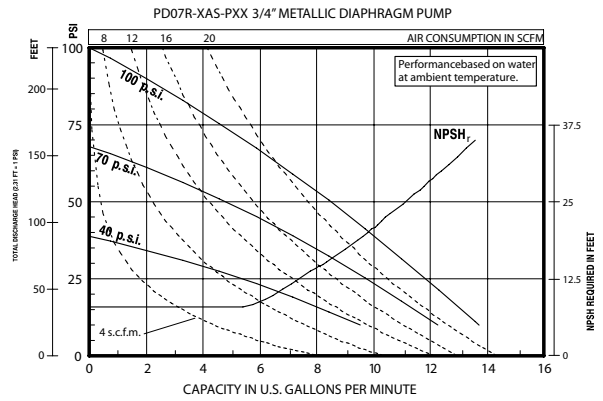

Refer to www.AROzone.com for full size flow curves.
For additional information contact
technical support at 1.800.495.0276

Ordering Position 10

Specialty Code 1 (Blank if no Specialty Code)

| | |
|---------------------|---|
| A - Solenoid 120VAC | G - Solenoid 12VDC ATEX/IECex* |
| B - Solenoid 12VDC | H - Solenoid 24VDC ATEX/IECex* |
| C - Solenoid 240VAC | J - 120VAC NEC/CEC* |
| D - Solenoid 24VDC | K - Solenoid 220VAC ATEX/IECex* |
| E - 12vDC NEC/CEC* | N - Solenoid with no coil |
| F - 24vDC NEC/CEC* | O - Standard Valve Block (No Solenoid) |
| | P - Ported Mortor (No major valve provided) |

Ordering Position 11

Specialty Code 2 (Blank if no Specialty Code)

| | |
|--|--|
| E - End of stroke feedback + Leak Detection | L - Leak Detection |
| F - End of stroke feedback | M - Leak Detection ATEX/IECex/NEC/CEC* |
| G - End of Stroke ATEX/IECex* | O - No Option |
| H - End of Stroke/Leak Detection ATEX/IECex* | R - End of Stroke Feedback NEC / CEC* |
| | T - End of Stroke Feedback + Leak Detection NEC / CEC* |

* Acceptable for use in hazardous locations. - NEC / CEC: Class I&II, Div 1&2
- ATEX: Zone 1&2, 21&22

1" Metallic Models

ARO® EXP 1" metallic diaphragm pumps achieve flow rates of up to 52.2 GPM (197.6 LPM) and offer a wide array of material and porting configurations. These pumps are often used for transfer, filling, recirculation and batching in ceramic, industrial, chemical and petrochemical markets.

UPGRADE
PUMP FOR REMOTE
ACTUATION CAPABILITY



- Ratio: 1:1
 Maximum GPM (LPM): 52 (197)
 Displacement per cycle Gallons (Liters): 0.232 (0.88)
 Air Inlet (Female): 1/4 - 18 N.P.T.
 Fluid Inlet/Outlet: 1 - 1 1/2 N.P.T.F.-1, Rp1(1-11 BSP)
 Max. operating pressure psi (bar): 120 (8.3)
 Suspended solids max. dia. in. (mm): 1/8" (3.3)
 Weight lbs (kg): PX10R-XAX-XXX 20.7 (9.4)
 PX10R-XCX-XXX 35.2 (16.0)
 PX10R-XHX-XXX 39.6 (18.0)
 PX10R-XSX-XXX 38.2 (17.3)
 Note: Add 4.65 lbs (2.11 kg) for aluminum air motor
 Add 11.09 lbs (5.03 kg) for stainless steel air motor
 Maximum dry suction lift ft(m): 19 (5.7)
 Sound Level: 70 PSI 60 Cycles/Min 80.6 db(A)
 Muffler Included: 93110

Ordering

| Position | 1 | 2 | | 3 | 4 | 5 | | 6 | 7 | 8 | | 9 | 10 |
|----------|-------------|----------|---|----------|----------|----------|---|----------|----------|----------|---|----------|----------|
| Example: | PX10 | X | - | X | X | X | - | X | X | X | - | X | X |

| Position 1 Model Series | Position 2 Center Section | Position 3 Connections | Position 4 Wetted Parts | Position 5 Hardware | Position 6 Seat Material | Position 7 Ball Material | Position 8 Diaphragm Material | Position 9 |
|--|--|-----------------------------------|---|----------------------------|--|--|---|--|
| PD10- Standard Pump PE10 - Electronic Interface Accessible Pump | A - Aluminum R - Polypropylene S - Stainless Steel | A - NPTF Thread B - BSP Thread | A - Aluminum* C - Cast Iron H - Hastelloy-C S - Stainless Steel* | P - Plated Steel S - SS | A - Santoprene® C - Hytrel® E - Carbon Steel F - Aluminum G - Nitrile H - 440 SS L - Hastelloy-C S - 316 SS | A - Santoprene® C - Hytrel® G - Nitrile S - 316 SS T - PTFE V - Viton | A - Santoprene® C - Hytrel® G - Buna- N L - Long-Life PTFE M - Medical Grade Santoprene® T - PTFE/Santoprene® V - Viton | Fluid control options for pump with electronic interface (PE10 model). See complete description on page 33 |

* Acceptable for use in hazardous locations. - NEC / CEC: Class I&II, Div 1&2
 - ATEX: Zone 1&2, 21&22

Accessories

- Air Line Connection Kit** | 66073-2
 (Piggyback Filter/Regulator with gauge, pipe nipple and 5-foot air hose)
Diaphragm Failure Detection | 67237
Cycle Counter Kit | 66350
Cycle Sensor Kit | 67350 (PE10X pump model is required)
Service Repair Kits | 637397 (air motor for PX10A, PX10R and PX10S),
 637401-XX (fluid section)
 637395-X (major air valve assembly)

1" Metallic Dimensions and Flow Charts

DIMENSIONS

- A - 12-11/32" (313.2 mm)
- B - 11-9/16" (293.7 mm)
- C - 4" (101.6 mm)
- D - 1-1/4" (31.8 mm)
- E - see below
- F - see below
- G - 12-7/16" (315.9 mm)
- H - 6-1/4" (158.8 mm)
- J - 7-5/16" (185.7 mm)
- K - 13/32" (10.3 mm)
- L - 1-1/2" (38.1 mm)
- M - 6-15/32" (164.3 mm)
- N - see below
- P - 5-27/32" (148.2 mm)
- Q - 12" (304.8 mm)
- R - see below

| | | | | |
|---------------|---------------------|--------------------|----------------------|---------------------|
| PX10A-XXX-XXX | "E" ----- | 8-1/8" (206.4 mm) | "F" ----- | 14-1/32" (356.2 mm) |
| PX10R-XXX-XXX | 11-1/32" (279.5 mm) | 8-5/16" (211.1 mm) | "R" ----- | |
| PX10S-XXX-XXX | ----- | 8-3/16" (207.9 mm) | 13-27/32" (351.4 mm) | |

| | |
|---------------|-------------------|
| PX10X-XAX-XXX | "N" 1/4" (6.4 mm) |
| PX10X-XCX-XXX | 9/32" (7.1 mm) |
| PX10X-XHX-XXX | 9/32" (7.1 mm) |
| PX10X-XSX-XXX | 9/32" (7.1 mm) |

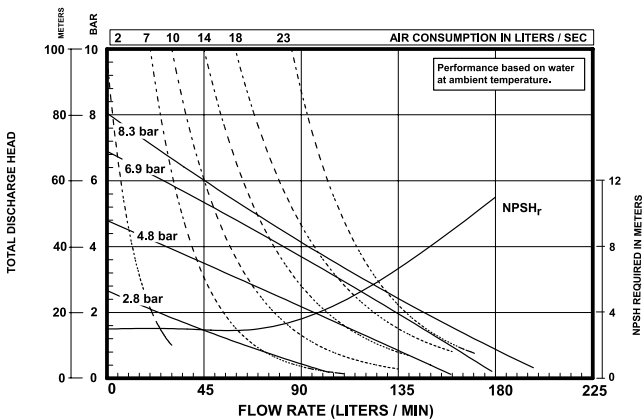
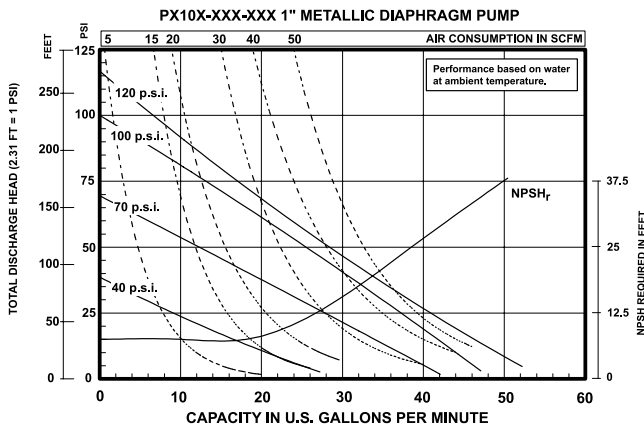
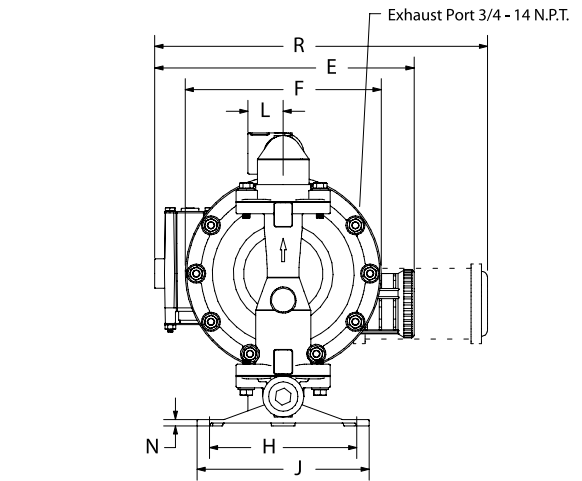
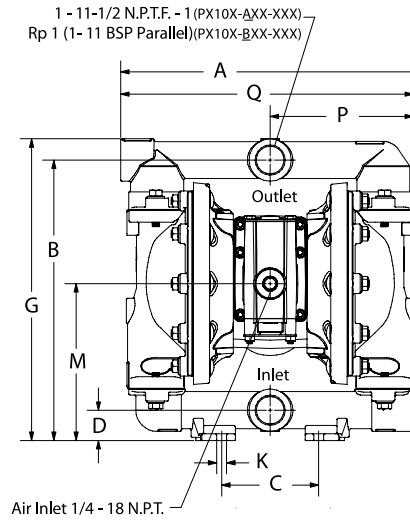

Refer to www.AROzone.com for full size flow curves.
For additional information contact technical support at 1.800.495.0276

Ordering Position 10

Specialty Code 1 (Blank if no Specialty Code)

- A - Solenoid 120VAC
- B - Solenoid 12VDC
- C - Solenoid 240VAC
- D - Solenoid 24VDC
- E - 12vDC NEC/CEC*
- F - 24vDC NEC/CEC*
- G - Solenoid 12VDC ATEX/IECex*
- H - Solenoid 24VDC ATEX/IECex*
- J - 120VAC NEC/CEC*
- K - Solenoid 220VAC ATEX/IECex*
- N - Solenoid with no coil
- O - Standard Valve Block (No Solenoid)
- P - Ported Mortor (No major valve provided)

Ordering Position 11

Specialty Code 2 (Blank if no Specialty Code)

- E - End of stroke feedback + Leak Detection
- F - End of stroke feedback
- G - End of Stroke ATEX/IECex*
- H - End of Stroke/Leak Detection ATEX/IECex*
- L - Leak Detection
- M - Leak Detection ATEX/IECex/NEC/CEC*
- O - No Option
- R - End of Stroke Feedback NEC / CEC*
- T - End of Stroke Feedback + Leak Detection NEC / CEC*

* Acceptable for use in hazardous locations. - NEC / CEC: Class I&II, Div 1&2
- ATEX: Zone 1&2, 21&22

1-1/2" Metallic Models

ARO® 1-1/2" metallic diaphragm pumps achieve flow rates of up to 123.1 GPM (465.9 LPM) and offer a wide array of material and porting configurations. These pumps are often used for transfer, filling, recirculation and batching in paint, oil and gas, chemical and petrochemical markets.

UPGRADE
PUMP FOR REMOTE
ACTUATION CAPABILITY

| | |
|--|--|
| Ratio: | 1:1 |
| Maximum GPM (LPM): | 123 (465) |
| Displacement per cycle Gallons (Liters): | 0.617 (2.34) |
| Air Inlet (Female): | 1/2 - 14 N.P.T. |
| Fluid Inlet/Outlet: | 1-1/2" - 11-1/2 N.P.T.F.-1, Rp1-1/2(1-1/2-11BSP) 1-1/2" A.N.S.I./DIN flange |
| Max. operating pressure psi (bar): | 120 (8.3) |
| Suspended solids max. dia. in.(mm): | 1/4" (6.4) |
| Weight lbs (kg): | PX15R-XAX-XXX 37.7 (17.1) PX15R-XCX-XXX 73.2 (33.2) PX15R-XSX-XXX 61.2 (27.8) PX15R-XHX-XXX 86.9 (39.4) |
| | Note: add 2.14 lbs (0.97 kg) for aluminum air motor section add 18.14 lbs (8.23 kg) for stainless steel air motor section |
| Maximum dry suction lift ft(m): | 14 (4.2) |
| Sound Level: | 70 PSI 50 Cycles/Min 81.0 db(A) |
| Muffler Included: | 350-568 |



Ordering

| Position | 1 | 2 | 3 | 4 | 5 | 6 | 7 | 8 | 9 | 10 | | | |
|----------|------|---|---|---|---|---|---|---|---|----|---|---|---|
| Example: | PX15 | X | - | X | X | X | - | X | X | X | - | X | X |

| Position 1 Model Series | Position 2 Center Section | Position 3 Connections | Position 4 Wetted Parts | Position 5 Hardware | Position 6 Seat Material | Position 7 Ball Material | Position 8 Diaphragm Material | Position 9 |
|---|--|--|---|---|--|--|---|--|
| PD15 - Standard Pump PE15 - Electronic Interface Accessible Pump | A - Aluminum* R - Polypropylene S - Stainless Steel* | A - NPTF Thread B - BSP Thread Y - 1-1/2" A.N.S.I./DIN Flange (Center) | A - Aluminum C - Cast Iron H - Hastelloy-C S - Stainless Steel | P - Plated Steel S - Stainless Steel | A - Santoprene® C - Hytrel® E - Carbon Steel F - Aluminum G - Nitrile H - 440 Stainless Steel L - Hastelloy-C S - 316 Stainless Steel | A - Santoprene® C - Hytrel® G - Nitrile S - 316 SS T - PTFE V - Viton | A - Santoprene® C - Hytrel® G - Buna- N L - Long-Life PTFE M - Medical Grade Santoprene® T - PTFE/Santoprene® V - Viton | Fluid control options for pump with electronic interface (PE15 model). See complete description on page 35 |

* Acceptable for use in hazardous locations. - NEC / CEC: Class I&II, Div 1&2
- ATEX: Zone 1&2, 21&22

Accessories

Air Line Connection Kit | 66084-1

(Piggyback Filter/Regulator with gauge, pipe nipple and 5-foot air hose)

Diaphragm Failure Detection | 67237

Cycle Counter Kit | 67350

Service Repair Kits | 637389 (air motor for PX15X), Kit No. 637375-XX (fluid section), 637390-X (major air valve assembly)

1-1/2" Metallic Dimensions and Flow Charts

| | | |
|------------------------|------------------------|-------------------------|
| A - see below | G - 19-5/8" (498.1 mm) | N - 9-11/16" (246.0 mm) |
| B - 18-3/8" (466.7 mm) | H - 9" (228.6 mm) | P - see below |
| C - 11-3/4" (298.5 mm) | J - 10" (254.0 mm) | Q - see below |
| D - 2-3/4" (69.9 mm) | K - 1/2" (12.7 mm) | R - 21-7/16" (543.9 mm) |
| E - see below | L - see below | S - see below |
| F - 10-1/4" (260.4 mm) | M - 1/4" (6.4 mm) | T - see below |

| | "A" | "L" |
|---------------------|----------------------|------------------|
| PX15X-XAX-XXX | 14-7/8" (377.8 mm) | 1-3/4" (44.5 mm) |
| PX15X-XCX-XXX | 14-5/8" (371.5 mm) | 1-3/4" (44.5 mm) |
| PX15X-HX-XXX | 14-9/16" (370.0 mm) | 3-1/8" (79.4 mm) |
| PX15X-ASX-XXX, -BSX | 14-25/32" (375.5 mm) | 1-3/4" (44.5 mm) |
| PX15X-YSX-XXX | 14-9/16" (370.0 mm) | 3-1/8" (79.4 mm) |

| | "E" | "T" |
|---------------|---------------------|----------------------|
| PX15A-XXX-XXX | ----- | 14-1/32" (356.2 mm) |
| PX15R-XXX-XXX | 11-3/32" (281.3 mm) | ----- |
| PX15S-XXX-XXX | ----- | 13-27/32" (351.4 mm) |

| "P" | "Q" | "S" |
|--------------------|----------------------|------------------|
| 7-7/32" (183.4 mm) | 14-23/32" (373.9 mm) | 1/2" (12.7 mm) |
| 7-3/16" (182.6 mm) | 14-1/2" (368.3 mm) | 1/4" (6.4 mm) |
| 7-3/16" (182.6 mm) | 14-1/2" (368.3 mm) | 1/4" (6.4 mm) |
| 7-9/32" (185.0 mm) | 14-13/16" (375.5 mm) | 15/32" (11.4 mm) |
| 7-9/32" (185.0 mm) | 14-9/16" (370.0 mm) | 15/32" (11.4 mm) |

| | "E" | "T" |
|---------------|---------------------|----------------------|
| PX15A-XXX-XXX | ----- | 14-1/32" (356.2 mm) |
| PX15R-XXX-XXX | 11-3/32" (281.3 mm) | ----- |
| PX15S-XXX-XXX | ----- | 13-27/32" (351.4 mm) |

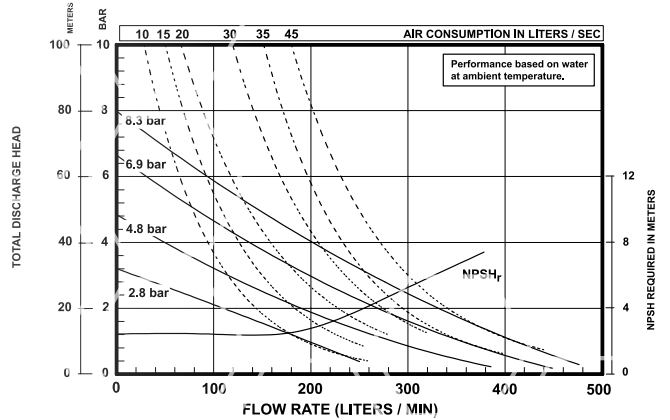
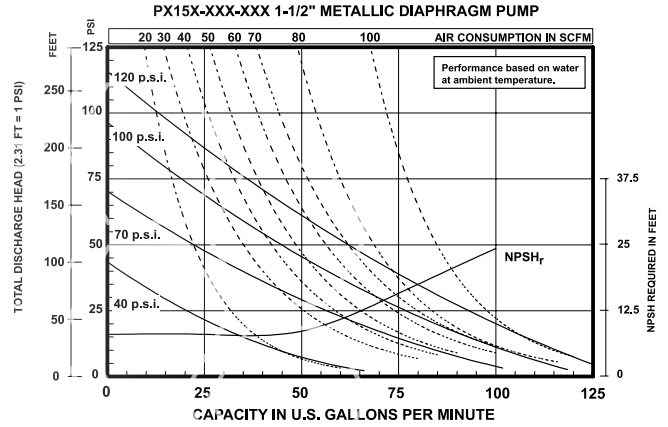
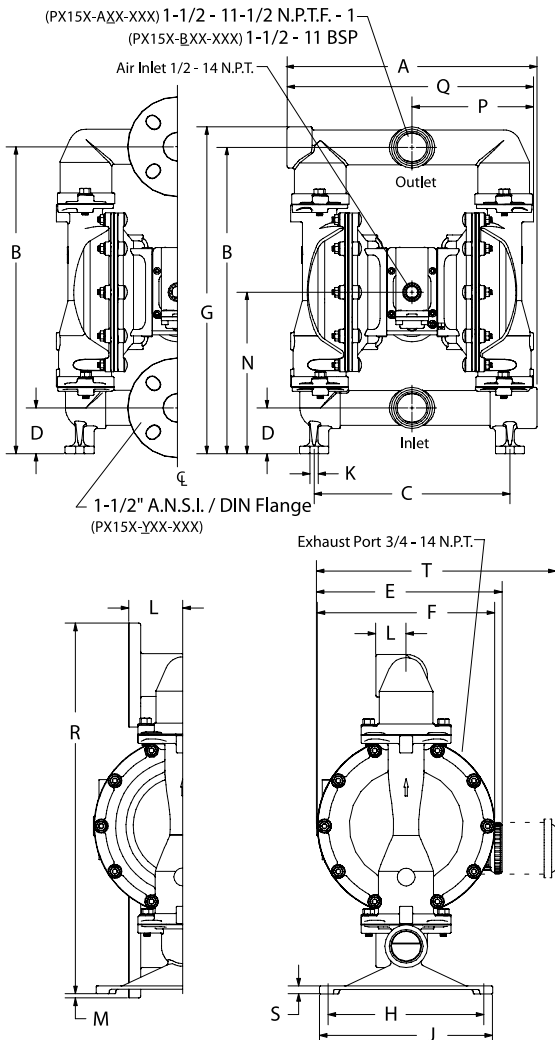

Ordering Position 10

Specialty Code 1 (Blank if no Specialty Code)

| | |
|---------------------|---|
| A - Solenoid 120VAC | G - Solenoid 12VDC ATEX/IECex* |
| B - Solenoid 12VDC | H - Solenoid 24VDC ATEX/IECex* |
| C - Solenoid 240VAC | J - 120VAC NEC/CEC* |
| D - Solenoid 24VDC | K - Solenoid 220VAC ATEX/IECex* |
| E - 12vDC NEC/CEC* | N - Solenoid with no coil |
| F - 24vDC NEC/CEC* | O - Standard Valve Block (No Solenoid) |
| | P - Ported Mortor (No major valve provided) |

Ordering Position 11

Specialty Code 2 (Blank if no Specialty Code)

| | |
|--|--|
| E - End of stroke feedback + Leak Detection | L - Leak Detection |
| F - End of stroke feedback | M - Leak Detection ATEX/IECex/NEC/CEC* |
| G - End of Stroke ATEX/IECex* | O - No Option |
| H - End of Stroke/Leak Detection ATEX/IECex* | R - End of Stroke Feedback NEC / CEC* |
| | T - End of Stroke Feedback + Leak Detection NEC / CEC* |

* Acceptable for use in hazardous locations. - NEC / CEC: Class I&II, Div 1&2
- ATEX: Zone 1&2, 21&22

2" Metallic Models

ARO® EXP 2" metallic pumps achieve flow rates of up to 172 GPM (651 LPM) and offer a wide array of material and porting configurations. These pumps are often used for transfer, filling, recirculation and batching in ceramic, paint, oil and gas, chemical and petrochemical markets.

UPGRADE
PUMP FOR REMOTE
ACTUATION CAPABILITY

Ratio: 1:1
 Maximum GPM (LPM): 172 (651)
 Displacement per cycle: 1.4 (5.3)
 @ 100 psi Gallons (Liters)
 Air Inlet (Female): 3/4 - 14 N.P.T.F.-1
 Fluid Inlet/Outlet (Female): PX20X-AXX-XXX-B() 2 - 11-1/2 N.P.T.F.-1
 PX20X-BXX-XXX-B() Rp 2 (2 - 11 BSP parallel)
 PX20X-FXX-XXX-B() 2" A.N.S.I./DIN Flange
 Max. operating pressure psi (bar): 120 (8.3)
 Suspended solids max. dia. in. (mm): 1/4" (6.4)
 Maximum dry suction lift ft (m): 14 (4.2)
 Sound Level: 70 PSI 50 Cycles/Min 85.0 db(A)
 Muffler Included: 67389
 Weight lbs (kg): AL-Aluminum, CI-Cast Iron, H-Hastelloy, SS-Stainless Steel



| | Air Motor | Connection | Wetted | Pump Wgt | | Air Motor | Connection | Wetted | Pump Wgt | | Air Motor | Connection | Wetted | Pump Wgt |
|--------------|-----------|------------|--------|--------------|--------------|-----------|------------|--------|--------------|--------------|-----------|------------|--------|--------------|
| PD20A | AL | Thread | AL | 91.4 (41.5) | PD20R | Poly | Thread | CI | 165 (74.8) | PD20S | SS | Thread | AL | 120.3 (54.6) |
| | AL | Thread | CI | 147.4 (66.9) | | Poly | Thread | H | 154 (69.9) | | SS | Thread | CI | 176.3 (80) |
| | AL | Thread | H | 155 (70.3) | | Poly | Thread | SS | 154 (69.9) | | SS | Thread | H | 183.9 (83.4) |
| | AL | Thread | SS | 149.8 (68) | | Poly | Flange | H | 153.2 (69.5) | | SS | Thread | SS | 178.7 (81.1) |
| | AL | Flange | H | 169.4 (76.8) | | Poly | Flange | SS | 146 (66.2) | | SS | Flange | H | 198.3 (89.9) |
| | AL | Flange | SS | 162.2 (73.6) | | | | | | | SS | Flange | SS | 191.1 (86.7) |

Ordering

| Position | 1 | 2 | | 3 | 4 | 5 | | 6 | 7 | 8 | | 9 | | 10 | 11 |
|----------|------|---|---|---|---|---|---|---|---|---|---|---|---|----|----|
| Example: | PX20 | X | - | X | X | X | - | X | X | X | - | B | - | X | X |

| Position 1 Model Series | Position 2 Center Section | Position 3 Connections | Position 4 Wetted Parts | Position 5 Hardware | Position 6 Seat Material | Position 7 Ball Material | Position 8 Diaphragm Material | Position 9 |
|---|--|---|---|----------------------------|--|--|--|--|
| PD20 - Standard Pump PE20 - Electronic Interface Accessible Pump | A - Aluminum R - Poly-propylene S - SS | A - NPTF Thread B - BSP Thread F [†] - 2" ANSI/DIN Flange Center † Stainless Steel Pumps Only | A - Aluminum* C - Cast Iron H - Hastelloy-C S - Stainless Steel* | P - Plated Steel S - SS | A - Santoprene® C - Hytrel® E - Carbon Steel F - Aluminum G - Nitrile H - 440 SS K - Kynar/PVDF L - Hastelloy-C S - 316 SS | A - Santoprene® C - Hytrel® G - Nitrile S - 316 SS T - PTFE V - Viton | A - Santoprene® C - Hytrel® G - Buna- N L - Long-Life PTFE M - Med. Grade Santoprene® T - PTFE/ Santoprene® V - Viton | Revision Level Position 10 & 11 Specialty Code Fluid control options for pump with electronic interface (PE20 model). See complete description on page 37 |

* Acceptable for use in hazardous locations. - NEC / CEC: Class I&II, Div 1&2
 - ATEX: Zone 1&2, 21&22

Accessories

Air Line Connection Kit | 66109

(Piggyback Filter/Regulator with gauge, pipe nipple and 5-foot air hose)

Diaphragm Failure Detection | 67237 (PE20X pump model is required)

Continuous-Duty Muffler | 67263

Muffler features large expansion chamber, permitting cold exhaust air to exit pump

Cycle Counter Kit | 66350 for PD20R-X and PD20Y-X, 67350-1, (PE20X pump model is required)

Service Repair Kits | 637369 (air motor for PX20R and PX20Y), 637421 (air motor for PX20A and PX20S), 637309-XX (fluid section), 637374-X (major air valve assembly)

2" Metallic Dimensions and Flow Charts

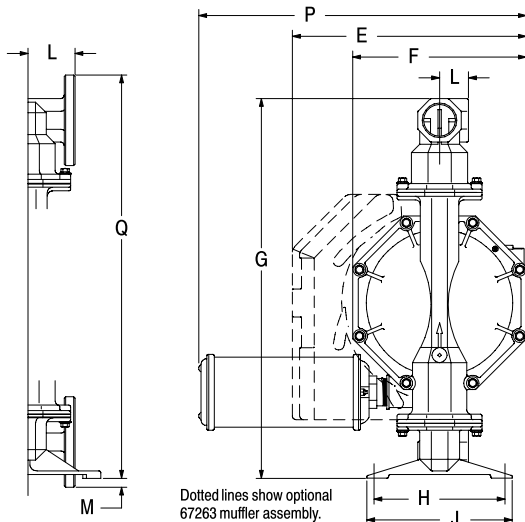
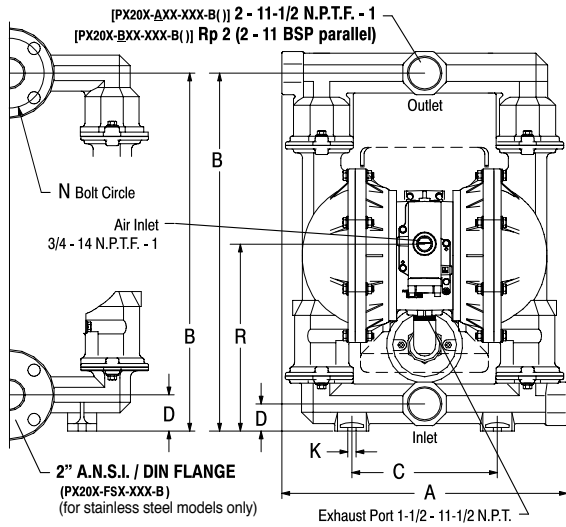

Dotted lines show optional 67263 muffler assembly.

DIMENSIONS

| | | |
|-----------------------|-----------------------|----------------------|
| A see below | G 26-1/4" (666.8 mm) | M 5/8" (15.9 mm) |
| B 24-3/4" (628.7 mm) | H 9-1/16" (230.2 mm) | N 4.834" (122.8 mm) |
| C 10-1/16" (255.6 mm) | J 10-1/16" (255.6 mm) | P 21-5/8" (548 mm) |
| D see below | K 9/16" (14.3 mm) | Q 27-7/8" (708.0 mm) |
| E 16-3/16" (411.2 mm) | L see below | R see below |
| F 12" (304.8 mm) | | |

| | | |
|--------------------------|--------------------|------------------|
| | "A" | "D" |
| PX20X-XAX-XXX-B() | 19-3/4" (501.4 mm) | 1-7/8" (47.6 mm) |
| PX20X-XCX-XXX-B() | 19-3/4" (501.4 mm) | 1-7/8" (47.6 mm) |
| PX20X-AHX-XXX-B(), -BHX | 19-1/4" (488.7 mm) | 2-1/2" (63.5 mm) |
| PX20X-ASX-XXX-B(), -BSX | 19-1/4" (488.7 mm) | 2-1/2" (63.5 mm) |
| PX20X-FHX-XXX-B(), -FSX | 19-1/4" (488.7 mm) | 2-1/2" (63.5 mm) |

| | |
|-------------------|----------------------|
| "L" | "R" |
| 2" (50.8 mm) | 12-15/16" (328.6 mm) |
| 2" (50.8 mm) | 12-15/16" (328.6 mm) |
| 2-3/32" (53.0 mm) | 13-9/16" (344.5 mm) |
| 2-3/32" (53.0 mm) | 13-9/16" (344.5 mm) |
| 3-1/4" (82.6 mm) | 13-9/16" (344.5 mm) |

PD20X-XXX-XXX-B / PE20X-XXX-XXX-B() 2" METALLIC DIAPHRAGM PUMP

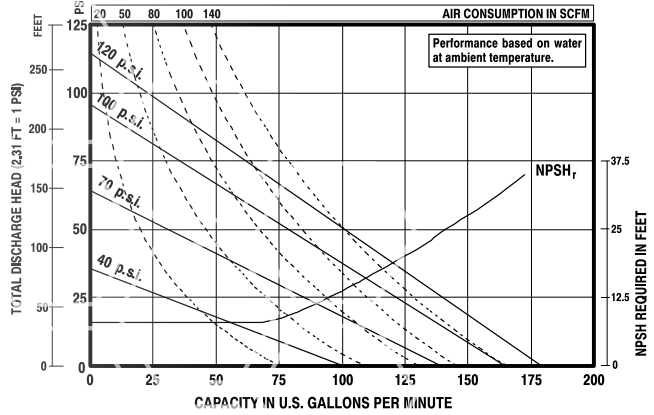

PD20X-XXX-XXX-B / PE20X-XXX-XXX-B() 2" METALLIC DIAPHRAGM PUMP

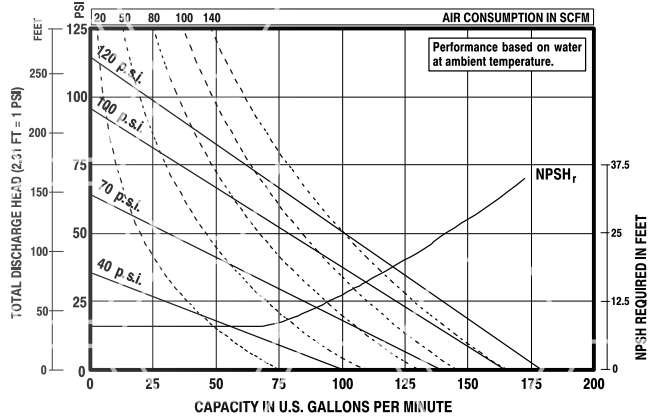

Ordering Position 10

Specialty Code 1 (Blank if no Specialty Code)

| | |
|---------------------|---|
| A - Solenoid 120VAC | G - Solenoid 12VDC ATEX/IECex* |
| B - Solenoid 12VDC | H - Solenoid 24VDC ATEX/IECex* |
| C - Solenoid 240VAC | J - 120VAC NEC/CEC* |
| D - Solenoid 24VDC | K - Solenoid 220VAC ATEX/IECex* |
| E - 12VDC NEC/CEC* | N - Solenoid with no coil |
| F - 24VDC NEC/CEC* | O - Standard Valve Block (No Solenoid) |
| | P - Ported Mortor (No major valve provided) |

Ordering Position 11

Specialty Code 2 (Blank if no Specialty Code)

| | |
|--|--|
| E - End of stroke feedback + Leak Detection | L - Leak Detection |
| F - End of stroke feedback | M - Leak Detection ATEX/IECex/NEC/CEC* |
| G - End of Stroke ATEX/IECex* | O - No Option |
| H - End of Stroke/Leak Detection ATEX/IECex* | R - End of Stroke Feedback NEC / CEC* |
| | T - End of Stroke Feedback + Leak Detection NEC / CEC* |

* Acceptable for use in hazardous locations. - NEC / CEC: Class I&II, Div 1&2
- ATEX: Zone 1&2, 21&22

3" Metallic Models

ARO® EXP 3" metallic diaphragm pumps achieve flow rates of up to 275 GPM (1040.9 LPM) and offer a wide array of material and porting configurations. These pumps are often used for transfer, filling, recirculation and batching in ceramic, paint, oil and gas, chemical and petrochemical markets.

UPGRADE
PUMP FOR REMOTE
ACTUATION CAPABILITY

| | |
|---|---|
| Ratio: | 1:1 |
| Maximum GPM (LPM): | 275 (1041) |
| Displacement per cycle: @ 100 psi Gallons (Liters) | 2.8 (10.6) |
| Air Inlet: (Female) | 3/4 - 14 N.P.T.F. - 1 |
| Fluid Inlet / Outlet (Female): | 3" - 8 N.P.T.F. - 1 Rp 3 (3 - 11 BSP parallel) |
| Max. operating pressure psi (bar): | 120 (8.3) |
| Suspended solids max. dia. in. (mm): | 3/8 (9.5) |
| Weight lbs (kg): | PX30A-XAX-XXX-C 129.5 (58.8) PX30A-XCX-XXX-C 221.1 (100.3) PX30A-AHX-XXX-C 249.4 (113.3) PX30A-ASX-XXX-C 228.3 (103.8) PX30A-FHX-XXX-C 269.4 (122.3) PX30A-FSX-XXX-C 245.2 (114.4) |
| | Note: Add 40 lbs (18.2 kg) for stainless steel air motor section |
| Maximum dry suction lift ft (m): | 14 (4.2) |
| Sound Level: | 70 PSI 50 Cycles / Min 83.0db(A) |
| Muffler Included: | 67389 |



Ordering

| Position | 1 | 2 | | 3 | 4 | 5 | | 6 | 7 | 8 | | 9 | | 10 | 11 |
|----------|------|---|---|---|---|---|---|---|---|---|---|---|---|----|----|
| Example: | PX30 | X | - | X | X | X | - | X | X | X | - | C | - | X | X |

| Position 1 Model Series | Position 2 Center Section | Position 3 Connections | Position 4 Wetted Parts | Position 5 Hardware | Position 6 Seat Material | Position 7 Ball Material | Position 8 Diaphragm Material | Position 9 |
|---|---|--|--|---|--|--|---|--|
| PD30 - Standard Pump PE30 - Electronic Interface Accessible Pump | A - Aluminum R - Polypropylene w/SS Air Caps S - Stainless Steel | A - NPTF Thread B - BSP Thread D - ANSI 4-hole flange F - DIN 8-hole flange | A - Aluminum* C - Cast Iron H - Hastelloy-C† S - Stainless Steel † Not available on PD30R-X models | P - Plated Steel S - Stainless Steel | A - Santoprene® C - Hytrel® E - Carbon Steel F - Aluminum G - Nitrile H - 440 SS K - PVDF L - Hastelloy S - 316 SS | A - Santoprene® C - Hytrel® G - Nitrile T - PTFE V - Viton | A - Santoprene® C - Hytrel® G - Buna-N L - Long-Life PTFE T - PTFE/Santoprene® V - Viton | Revision Level Position 10 & 11 Specialty Code Fluid control options for pump with electronic interface (PE30 model). See complete description on page 39 |

* Acceptable for use in hazardous locations. - NEC / CEC: Class I&II, Div 1&2
- ATEX: Zone 1&2, 21&22

Accessories

Air Line Connection Kit | 66109

(Piggyback Filter/Regulator with gauge, pipe nipple and 5-foot air hose)

Diaphragm Failure Detection | 67237, (PE30X pump model is required)

Cycle Sensor Kit | 67350-1 (PE30X pump model is required)

Service Repair Kits | 637369 (air motor for PX30R), Kit No. 637421 (air motor for PX30A and PX30S),
637374-X (major air valve assembly), Kit No. 637303-XX (fluid section)

Continuous-Duty Muffler | 67263 Muffler features large expansion chamber, permitting cold exhaust air to exit pump

3" Metallic Dimensions and Flow Charts

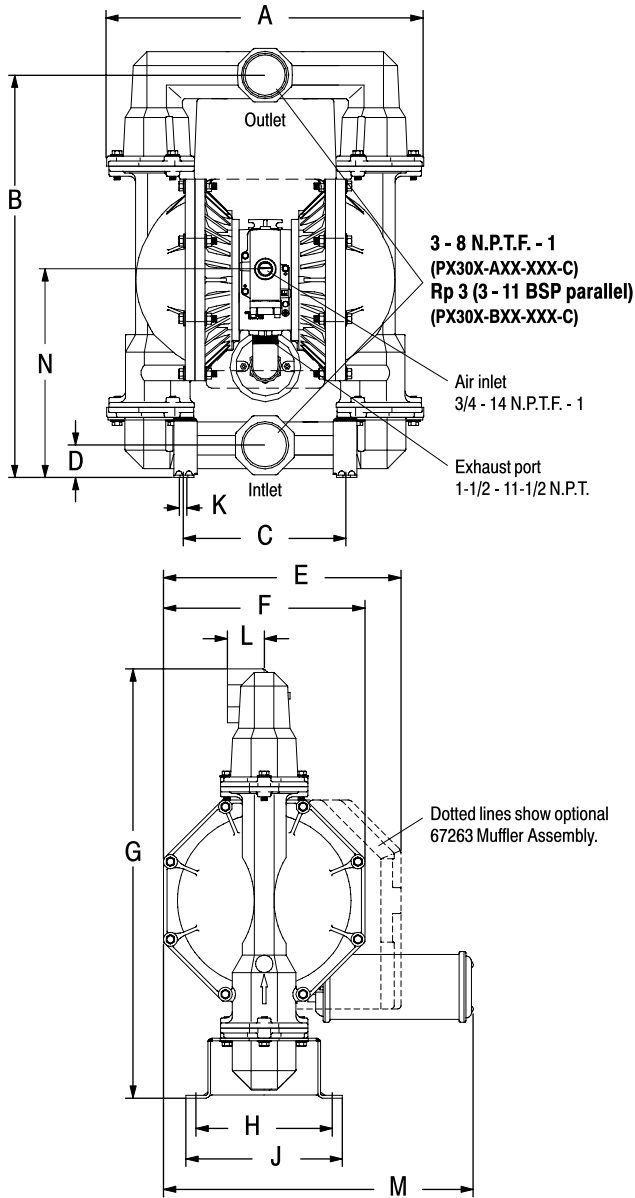

DIMENSIONS

| | | |
|------------------------|---------------------|-----------------------|
| A see below | F 15" (381 mm) | K 9/16" (14.3 mm) |
| B 30" (761.7 mm) | G 32" (812.5 mm) | L 2-3/4" (69.9 mm) |
| C 12-1/16" (306.5 mm) | H 10-5/32" (258 mm) | M 23-3/32" (586.3 mm) |
| D see below | J see below | N see below |
| E 17-11/16" (449.2 mm) | | |

| | "A" | "D" |
|-----------------|--------------------|-------------------|
| PX30X-XAX-XXX-C | 23-5/8" (598.7 mm) | 2-3/8" (60.3 mm) |
| PX30X-XCX-XXX-C | 23-5/8" (598.7 mm) | 2-7/16" (61.1 mm) |
| PX30X-XHX-XXX-C | 23-1/8" (587.3 mm) | 2-3/4" (69.9 mm) |
| PX30X-XSX-XXX-C | 23-1/8" (587.3 mm) | 2-3/4" (69.9 mm) |

| "J" | "N" |
|----------------------|--------------------|
| 11" (279.4 mm) | 15-1/2" (393.7 mm) |
| 11-11/16" (296.1 mm) | 15-1/2" (393.7 mm) |
| 11-11/16" (296.1 mm) | 16" (406.4 mm) |
| 11-11/16" (296.1 mm) | 16" (406.4 mm) |

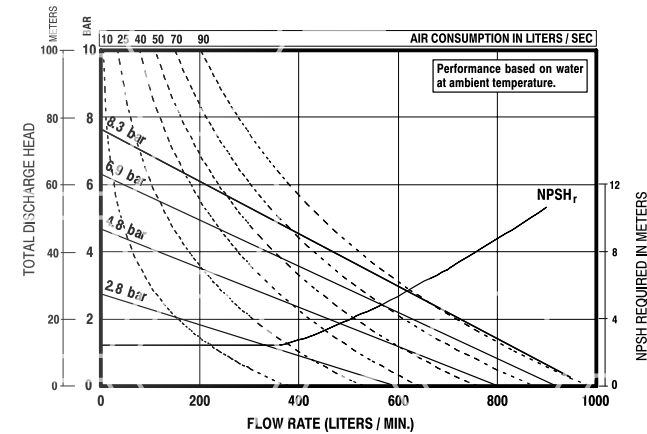
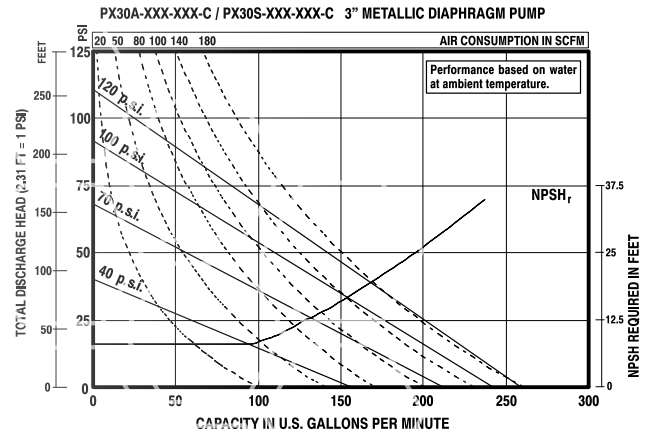

Ordering Position 10

Specialty Code 1 (Blank if no Specialty Code)

| | |
|---------------------|---|
| A - Solenoid 120VAC | G - Solenoid 12VDC ATEX/IECex* |
| B - Solenoid 12VDC | H - Solenoid 24VDC ATEX/IECex* |
| C - Solenoid 240VAC | J - 120VAC NEC/CEC* |
| D - Solenoid 24VDC | K - Solenoid 220VAC ATEX/IECex* |
| E - 12vDC NEC/CEC* | N - Solenoid with no coil |
| F - 24vDC NEC/CEC* | O - Standard Valve Block (No Solenoid) |
| | P - Ported Mortor (No major valve provided) |

Ordering Position 11

Specialty Code 2 (Blank if no Specialty Code)

| | |
|--|--|
| E - End of stroke feedback + Leak Detection | L - Leak Detection |
| F - End of stroke feedback | M - Leak Detection ATEX/IECex/NEC/CEC* |
| G - End of Stroke ATEX/IECex* | O - No Option |
| H - End of Stroke/Leak Detection ATEX/IECex* | R - End of Stroke Feedback NEC / CEC* |
| | T - End of Stroke Feedback + Leak Detection NEC / CEC* |

* Acceptable for use in hazardous locations. - NEC / CEC: Class I&II, Div 1&2
- ATEX: Zone 1&2, 21&22

Batching/Flow Control

CONTROLLER

The ARO® Controller works seamlessly with ARO® EXP Electronic Interface pumps, and creates a fully automated multi-pump system that helps manufacturers and operators manage fluid easily and intelligently, with less operator oversight required. Migrate to a smart touch-and-walk-away system that helps optimize your costs and production time.

- ▶ Closed loop system achieves dispensing repeatability within 1%.
- ▶ Safe control and monitoring via remote operation.
- ▶ Multi-pump control for accurate batching processes.
- ▶ Controller accepts leak detection, liquid level sensing and proportional control.
- ▶ Remote triggers and alerts send operating data, can perform auto shut-down, and keep you up-to-date on maintenance needs.
- ▶ Seamless integration between the ARO® Controller and EXP Series Electronic Interface pumps or PD pumps that have been upgraded.



Choose a Controller

| Model Options | |
|------------------------|-------------|
| Base Controller | 651763-XX-0 |
| Interface with 1 Pump | 651763-XX-1 |
| Interface with 2 Pumps | 651763-XX-2 |

XX = AM (Americas), EM (Europe, Middle East, India and Africa), AP (Asia/Pacific)

Choose a Pump

| Position | 1 | 2 | 3 | | 4 | 5 | 6 | | 7 | 8 | 9 | | 10 | 11 | 12 |
|----------|----|----|---|---|---|---|---|---|---|---|---|---|----|----|----|
| Example: | PE | 05 | P | - | A | P | S | - | P | A | A | - | B | D | E |

| Position 1 Model Series | Position 2 Port Size | Position 3 Center Section Material | Position 4 Connection | Position 5 Wetted Parts | Position 6 Hardware | Position 7 Seat Material | Position 8 Ball Material |
|----------------------------|--|--|--|--|---|---|--|
| PE - Electronic Interface | 01 - 1/4" Port 03 - 3/8" Port 05 - 1/2" Port 07 - 3/4" Port 10 - 1" Port 15 - 1-1/2" Port 20 - 2" Port 30 - 3" Port | A - Aluminum P - Polypropylene S - Stainless Steel | A - NPT Thread B - BSP thread F - A.N.S.I. Side Y - A.N.S.I. Center | A - Aluminum* C - Cast Iron D,E - Groundable Acetal* H - Hastelloy K,L - PVDF (Kynar) P,R - Polypropylene S - Stainless Steel* | P - Plated Steel S - Stainless Steel | A - Santoprene® C - Hytrel® D - Acetal E - Carbon Steel F - Aluminum G - Nitrile H - 440 SS Hard K - PVDF L - Hastelloy P - Polypropylene S - Stainless Steel | A - Santoprene® C - Hytrel® G - Nitrile S - 316 SS T - PTFE U - Polyurethane V - Viton |

| Position 9 Diaphragm Material | Position 10 Revision | Position 11 Specialty Code 1 | | Position 12 Specialty Code 2 |
|--|--------------------------------------|--|--|--|
| A - Santoprene C - Hytrel G - Nitrile T - PTFE V - Viton | A - First B - Second C - Third | A - Solenoid 120VAC, 110VAC + 60VDC B - Solenoid 12VDC, 24VAC + 22VDC C - Solenoid 240VAC, 220VAC + 120VDC D - Solenoid 24VDC, 48VAC + 44VACA† E - Solenoid 12VDC NEC/CEC* F - Solenoid 24VDC NEC/CEC*† G - Solenoid 12VDC ATEX/IECex* H - Solenoid 24VDC ATEX/IECex* | J - 120VDC NEC/CEC* K - Solenoid 220VDC ATEX/IECex* N - Solenoid with no coil O - Standard Valve Block (No Solenoid) P - Ported Mortor (No major valve provided) | E - End of stroke feedback + Leak Detection F - End of stroke feedback G - End of Stroke ATEX/IECex* H - End of Stroke feedback + Leak Detection ATEX / IECex* L - Leak Detection M - Leak Detection ATEX/IECex/NEC/CEC* O - No Option R - End of Stroke Feedback NEC / CEC* T - End of Stroke Feedback + Leak Detection NEC / CEC |

* Acceptable for use in hazardous locations. - NEC / CEC: Class I&II, Div 1&2
- ATEX: Zone 1&2, 21&22

† only solenoid voltages that will work with controller

2" Metallic Flap Valve Models

SPECIALTY PUMP

ARO's pneumatic flap valve diaphragm pumps provide effective flow rates up to 172 gpm (651 lpm). These pumps are designed to handle materials that are stringy, fibrous, large solids (suspended or non-suspended), abrasive, slurries and other applications less suited for ball check style pumps. Flap valve pumps are useful for feeding filter presses, waste treatment, dewatering, filled material transfer and a variety of other demanding applications.

| | |
|--------------------------------------|---|
| Ratio: | 1:1 |
| Maximum GPM (LPM): | 172 (651) |
| Displacement per cycle: | 1.4 (5.3) |
| @ 100 psi Gallons (Liters) | |
| Air Inlet (Female): | 3/4 - 14 N.P.T.F.-1 |
| Fluid Inlet/Outlet (Female): | PF20X-AXX-XXX-B 2 - 11-1/2 N.P.T.F.-1 PF20X-BXX-XXX-B Rp 2 (2 - 11 BSP parallel) |
| Max. operating pressure psi (bar): | 120 (8.3) |
| Suspended solids max. dia. in. (mm): | 2" (51) Semi-solid |
| Maximum dry suction lift ft (m): | 14 (4.2) |
| Weight lbs (kg): | PF20A-XAX-SXX-B 97.3 (44.2) PF20A-XCX-SXX-B 166.2 (75.4) PF20A-ASX-SXX-B 166 (75.3) PF20A-BSX-SXX-B 166 (75.3) PF20A-FSX-SXX-B 177.1 (80.3) Add 28.9 lbs (13.1kg) for stainless steel air motor PF20R-XCX-SXX-B 178.7 (81.1) PF20R-XSX- SXX- B 180.6 81.9) |
| Sound Level: | 70 PSI 60 Cycles / Min 85.0 db(A) |
| Muffler: | 94810 (optional 94117) |



Ordering

| Position | 1 | 2 | | 3 | 4 | 5 | | 6 | 7 | 8 | | |
|----------|------|---|---|---|---|---|---|---|---|---|---|---|
| Example: | PF20 | X | - | X | X | X | - | S | X | X | - | B |

| Position 1 Model Series | Position 2 Center Section | Position 3 Connections | Position 4 Wetted Parts | Position 5 Hardware | Position 6 Seat Material | Position 7 Flap Material | Position 8 Diaphragm Material |
|-------------------------------|---|---|---|---|--------------------------------|---|---|
| PF20 - Standard Pump | A - Aluminum R - Polypropylene w/SS Air Caps S - Stainless Steel Y - Polypropylene w/CI Air Caps | A - NPTF Thread B - BSP Thread F - 2" ANSI/DIN Flange | A* - Aluminum C - Cast Iron S - Stainless Steel * Not available with PD20R or PD20Y option | P - Plated Steel S - Stainless Steel | S - Stainless Steel | A - EPR G - Nitrile U - Polyurethane V - Viton | A - Santoprene® G - Buna- N T - PTFE/ Santoprene® V - Viton |

Accessories

Service Repair Kits | 637421 (air motor)
637310-XX (fluid section)

Powder Transfer

SPECIALTY PUMP

Transfer and handle your dry process powders faster, cleaner and at a fraction of the cost associated with installed “systems.” Consistent trouble-free transfer of powders up to 45-lbs. per cubic foot (721 kgs. per cubic meter) dry-weight, such as carbon black, expanded mica, silicones, acrylic resins and pharmaceuticals

Replace Manual Powder Processes.

- Reduce Airborne Contamination - With direct transfer from the powder container to your recipe.
- Unique Patented Air-Induction System - Avoids the possibility of powder pack-out.
- Portable - Can be moved from site to site.

| | |
|--------------------------------------|---|
| Port: | 2" and 3" |
| Material: | Aluminum and Stainless Steel |
| Max. operating pressure psi (bar): | 50 (3.4) |
| Suspended solids max. dia. in. (mm): | 1/4" (6.4) PP20A Models 3/8" (9.5) PP30A Models |
| Weight: lbs (kg) | PP20A-XAX-AAA 99.4 (45.1) PP20A-XSX-AAA 157.8 (71.6) P30A-XAX-AAA 137.5 (62.4) PP30A-XSX-AAA 236.8 (107.4) |



Ordering

| Position | 1 | | 2 | 3 | 4 | | 5 | 6 | 7 |
|----------|-------|---|---|---|---|---|---|---|---|
| Example: | PP20A | - | X | X | X | - | X | X | X |

| Position 1 Model Series | Position 2 Connections | Position 3 Wetted Parts | Position 4 Hardware | Position 5 Seat Material | Position 6 Ball Material | Position 7 Diaphragm Material |
|-------------------------|---|-------------------------------------|---|--|--|--|
| PP20A - 2" Port | A - 2-11-1/2 NPTF - 1 B - Rp2 (2-11 BSP Parallel) C - 2"ANSI DIN Flange | A - Aluminum S - Stainless Steel | P - Plated Steel S - Stainless Steel | A - Santoprene® S - Stainless Steel | A - Santoprene® M - Medical Grade Santoprene® | A - Santoprene® M - Medical Grade Santoprene® |

| Position | 1 | | 2 | 3 | 4 | | 5 | 6 | 7 |
|----------|-------|---|---|---|---|---|---|---|---|
| Example: | PP30A | - | X | X | X | - | X | X | X |

| Position 1 Model Series | Position 2 Connections | Position 3 Wetted Parts | Position 4 Hardware | Position 5 Seat Material | Position 6 Ball Material | Position 7 Diaphragm Material |
|-------------------------|---|-------------------------------------|---|--------------------------|--------------------------|-------------------------------|
| PP30A - 3" Port | A - 3-8 NPTF - 1 B - Rp3 (3-11 BSP parallel) F - 3" ANSI/DIN Flange | A - Aluminum S - Stainless Steel | P - Plated Steel S - Stainless Steel | A - Santoprene® | A - Santoprene® | A - Santoprene® |

Accessories

Service Repair Kits | 637421 (air motor PP20A), 637421 (air motor PP30A),
637309-XX (fluid section PP20A), 637303-XX (fluid section PP30A)

Suction Probe: 67183-1

Sanitary Transfer

SPECIALTY PUMP

- Constructed of FDA accepted materials.
- Electro-polished 316 stainless steel fluid section.
- Bolted construction with all stainless steel hardware.
- All investment cast wetted parts.

Typical Applications:

- Food Processing
- Cosmetics
- Pharmaceutical
- Chemical Additives
- Adhesives (Food grade)
- Paint
- Applications Requiring Quick-Disconnect Fluid Connections



| | PM05X-X-X-B02 (1/2") | PM10X-X-X-A02 (1") | PM15X-X-X-A02 (1-1/2") | PM20X-X-X-B02 (2") | PM30X-X-X-C02 (3") |
|------------------------------------|------------------------------------|--------------------------------|--------------------------------|--|--|
| Ratio: | 1:1 | 1:1 | 1:1 | 1:1 | 1:1 |
| Maximum GPM (lpm): | 13.0 (49.2) | 52.2 (197.6) | 123 (465.6) | 172 (651) | 275 (1041) |
| Displacement per Cycle GPM (lpm): | 0.040 (0.15) | 0.232 (0.88) | 0.617 (2.34) | 1.4 (5.3) | 2.8 (10.6) |
| Air Inlet (Female): | 1/4 - 18 PTE SAE Short | 1/4 - 18 N.P.T.F | 1/2 - 14 N.P.T.F | 3/4 - 14 N.P.T.F-1 | 3/4 - 14 N.P.T.F-1 |
| Fluid Inlet: | 1-1/2" Tri-Clamp | 1-1/2" Tri-Clamp | 2" Tri-Clamp | 2-1/2" Tri-Clamp | 3" Tri-Clamp |
| Fluid Outlet: | 1-1/2" Tri-Clamp | 1-1/2" Tri-Clamp | 2" Tri-Clamp | 2-1/2" Tri-Clamp | 3" Tri-Clamp |
| Max. Operating Pressure: PSI (bar) | 100 (6.9) | 120 (8.3) | 120 (8.3) | 120 (8.3) | 120 (8.3) |
| Suspended solids in.(mm): | 3/32" (2.4) | 1/8" (3.3) | 1/4" (6.4) | 1/4" (6.5) | 3/8" (9.5) |
| Weight lbs (kg.): | 14.75 (6.7) | PM10A-CSS-X-A02 44.8 (20.3) | PM15A-CSS-X-A02 62.4 (28.3) | PM20A-CSS-X-B02 142.8 (64.8) | PM30A-CSS-X-C02 227.5 (103.2) |
| | | PM10R-CSS-X-A02 38.2 (17.3) | PM15R-CSS-X-A02 60.3 (27.3) | PM20R-CSS-X-B02 183.6 (83.5) | PM30R-CSS-X-C02 253.3 (114.9) |
| | | PM10S-CSS-X-A02 51.6 (23.4) | PM15S-CSS-X-A02 78.4 (35.6) | PM20S-CSS-X-B02 171.7 (77.9) | PM30S-CSS-X-C02 267.2 (121.2) |
| Optional Muffler | 93110 (requires 67367 assembly) | | | 67213 (Standard Duty) 67263 (continuous Duty) | 67213 (Standard Duty) 67263 (continuous Duty) |

Ordering (Not all options available for each pump size, consult operator's manual for available options.)

| Position | 1 | 2 | | 3 | 4 | 5 | | 6 | 7 | 8 | 9 |
|----------|------|---|---|---|---|---|---|---|---|---|-----|
| Example: | PMXX | X | - | X | X | X | - | X | X | X | X02 |

| Position 1 Model Series | Position 2 Center Section | Position 3 Connection | Position 4 Wetted Parts | Position 5 Hardware | Position 6 Seat Material | Position 7 Ball Material | Position 8 Diaphragm Material | Position 9 Revision Level |
|--|--|-----------------------|-------------------------|---------------------|---|---|---|---------------------------|
| PM05 - 1/2" Pump PM10 - 1" Pump PM15 - 1-1/2" Pump PM20 - 2" Pump PM30 - 3" Pump | A - Aluminum P - Polypropylene S - Stainless Steel | C - Tri-Clamp | S - Stainless Steel | S - Stainless Steel | A - Santoprene® P - Polypropylene S - Stainless Steel | A - Santoprene® C - Hytrel® G - Nitrile S - Stainless Steel T - PTFE V - Viton | A - Santoprene® C - Hytrel® G - Nitrile M - Med. Grade Santoprene® T - PTFE/ Santoprene® | |

FDA Compliant Pumps

SPECIALTY PUMP

Our SD line features the Quick Knock Down (QKD) compression clamp system to facilitate easier cleaning, service and maintenance, which promotes reliability and long product life.

SD Series Pumps

- Quick Knock Down (QKD) design facilitates rapid disassembly.
- Flow-rate optimized. Better overall performance, low material shear.
- Electropolish stainless-steel 316L construction FDA compliance and high temperature capability.

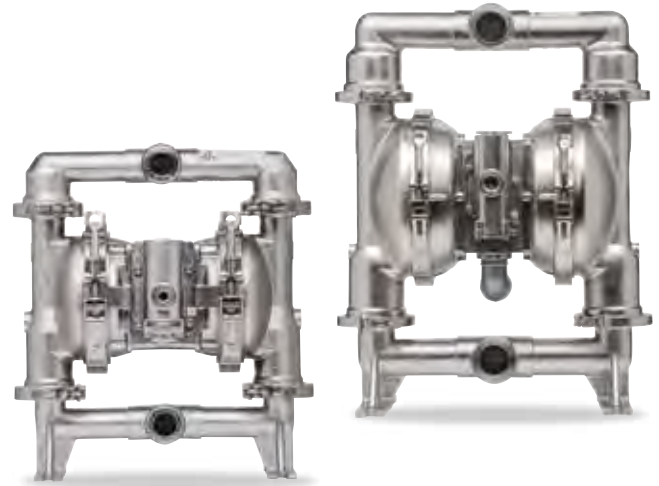

Applications:

Food / Beverage / Pharmaceutical / Cosmetics

| | SD10S-CSS-SXX-A / 1" Pump | SD20S-CSS-SXX-A / 2" Pump |
|--|---------------------------|---------------------------|
| Startup Pressure PSI (bar) | 25 (1.723) | 25 (1.723) |
| Dry suction lift ft. H2O (m) | 16.49 (5.02) | 18.25 (5.56) |
| Wet suction lift ft. H2O (m) | 31.4 (9.57) | 31.4 (9.57) |
| Flow Rate GPM (lpm) | 54 (204.4) | 195 (738) |
| Displacement per/cycle GPM @ 100 PSI (lpm) | 0.258 (.976) | 1.3 (4.9) |
| Max. Solids Passage in. (mm) | 1/8 (3.2) | 1/4 (6.4) |
| Fluid Inlet/Outlet | 1-1/2" Tri-Clamp | 2-1/2" Tri-Clamp |

Ordering

| Position | 1 | 2 | | 3 | 4 | 5 | | 6 | 7 | 8 | | 9 | 10 | 11 | 12 |
|----------|------|---|---|---|---|---|---|---|---|---|---|---|----|----|----|
| Example: | SDXX | X | - | C | S | S | - | X | X | X | - | X | X | X | X |

| Position 1 Model Series | Position 2 Center Section | Position 3 Port | Position 4 Fluid Caps & Manifold Mat. | Position 5 Hardware | Position 6 Seat Material | Position 7 Ball Material | Position 8 Diaphragm Material | Position 9 |
|----------------------------------|--|------------------------|--|------------------------|--|--|--|----------------------------|
| SD10 - 1" Pump SD20 - 2" Pump | R - White Polypropylene S - 316 SS | C - Sanitary Flange | S - 316L Stainless Steel* | S - Stainless Steel | C - Hytrel K - PVDF S - 316L Stainless Steel | C - Hytrel® M - Medical Grade Santoprene® S - 316L SS T - PTFE | C - Hytrel® M - Med. Grade Sant. T - PTFE/Santoprene® K - PTFE Single Piece | A - 1" Pump B - 2" Pump |

| Position 10 Specialty Code 1 (blank if no specialty code) | Position 11 Specialty Code 2 (blank if no specialty code) | Position 12 Special Test |
|--|--|--|
| A - Solenoid 120VAC, 110VAC + 60VDC B - Solenoid 12VDC, 24VAC + 22VDC C - Solenoid 240VAC, 220VAC + 120VDC D - Solenoid 24VDC, 48VAC + 44VACA E - Solenoid 12VDC NEC/CEC* F - Solenoid 24VDC NEC/CEC* G - Solenoid 12VDC ATEX/IECex* H - Solenoid 24VDC ATEX/IECex* J - Solenoid 120VDC NEC/CEC* | K - Solenoid 220VDC ATEX/IECex* N - Solenoid with no coil O - Standard Valve Block (No Solenoid) | E - End of stroke feedback + Leak Detection F - End of stroke feedback G - End of Stroke ATEX/IECex* H - End of Stroke feedback + Leak Detection ATEX / IECex* L - Leak Detection M - Leak Detection ATEX/IECex/NEC/CEC* O - No Option R - End of Stroke Feedback NEC / CEC* T - End of Stroke Feedback + Leak Detection NEC / CEC |

* Acceptable for use in hazardous locations. - NEC / CEC: Class I&II, Div 1&2
- ATEX: Zone 1&2, 21&22

2:1 Ratio High Pressure

SPECIALTY PUMP

The high pressure pump was developed for applications requiring fluid pressures in excess of the 100 psi developed by traditional pumps. Compared to a standard diaphragm pump, the 2:1 ratio high-pressure pump can produce up to 200 psi, at about half the flow rate.

The 2:1 ratio is accomplished by using the effective surface area of both diaphragms to double the output pressure.

2:1 Ratio High-Pressure Pump

- ✔ Bolted construction for leak free integrity.
- ✔ Simul-shift and quick dump valve technology for stall free / ice free performance.
- ✔ Convoluted diaphragms for long life.
- ✔ Modular major valve for ease of repair.



Applications:

- High viscosity fluids
- High solids fluids
- Charging filter presses
- High head / back pressure

| Model | Maximum Gallons GPM (Liters) | Displacement Cycles Per Gallons @ 100 PSI (Liters) | Weight (kg) | Suspended Solids Max. Dia. in. (mm) | Maximum Outlet pressure PSI (bar) |
|---------------------------------|------------------------------|--|-------------|-------------------------------------|-----------------------------------|
| 2:1 Ratio 1 1/2" Diaphragm Pump | 63 (238.48) | 0.88 (3.33) | 88 (39.9) | 1/4 (6.4) | 200 (13.8) |
| 2:1 Ratio 2" Diaphragm Pump | 92 (348.25) | 1.28 (4.8) | 146 (66.2) | 1/4 (6.4) | 200 (13.8) |
| 2:1 Ratio 3" Diaphragm Pump | 160 (605.6) | 1.4 (5.3) | 268 (121.6) | 3/8 (9.5) | 200 (13.8) |

Ordering

| Position | 1 | 2 | | 3 | | | | 4 | 5 | 6 | | 7 |
|----------|------|---|---|---|---|---|---|---|---|---|---|---|
| Example: | PHXX | F | - | X | S | P | - | S | X | X | - | C |

| Position 1 Model Series | Position 2 Center Section | Position 3 Connection | Position 4 Seat Material | Position 5 Ball Material | Position 6 Diaphragm Material | Position 7 Revision Level |
|---|--|---|--------------------------|--|--|--------------------------------|
| PH15 - 1 1/2" PH20 - 2" PH30 - 3" | F - Conductive Polypropylene/ Stainless Steel | A - 1-1/2 NPTF B - 1-1/2 BSP parrallel F - 1-1/2 ANSI /DIN Flange | S - Stainless Steel | A - Santoprene® T - PTFE C - Hytrel® | A - Santoprene® C - Hytrel® L - Long-Life PTFE T - PTFE/Santoprene® | A - 1 1/2" B - 2" C - 3" |

Accessories

| | PH15 - 1 1/2" | PH20 - 2" | PH30 - 3" |
|---------------------------|---------------|------------|------------|
| Filter/Regulator | P39344-614 | P39354-614 | P39454-614 |
| Air Line Kit | 66084-1 | 66109 | 66109 |
| Air Section Service Kit | 637389 | 637369 | 637369 |
| Fluid Section Service Kit | 637445-XX | 637446-XX | 637441-CC |

1" PW Series

SPECIALTY PUMP

ARO PW10X-X EXP Pumps

- Upgrade to EXP from existing Wilden® P4,T4 or M4 pumps, or Versa-Matic® E4 pumps.
- The ARO® PW10X-X matches the fluid inlet/outlet port dimensions of these other pumps
- Leave the stalling issues and leaking band-clamps behind.



| | |
|--|-----------------------------------|
| Ratio: | 1:1 |
| Maximum GPM (LPM): | 60 (227.1) |
| Displacement per cycle Gallons (Liters): | 0.234 (0.89) |
| Air Inlet (Female): | 1/2 - 14 N.P.T. |
| Fluid Inlet: | 1-1/2 - 11-1/2 N.P.T.F. - 1 |
| Fluid Outlet: | 1-1/4 - 11-1/2 N.P.T.F. - 1 |
| Max. operating pressure psi (bar): | 120 (8.3) |
| Suspended solids max. dia. in. (mm): | 1/8" (3.3) |
| Weight lbs (kg): | PW10A-XXX-XXX 25.7 (11.7) |
| Maximum dry suction lift ft (m): | 19 (5.8) |
| Sound Level: | 70 PSI 60 Cycles / Min 80.6 db(A) |

Ordering

| Position | 1 | 2 | | 3 | 4 | 5 | | 6 | 7 | 8 |
|----------|------|---|---|---|---|---|---|---|---|---|
| Example: | PW10 | A | - | X | X | X | - | X | X | X |

| Position 1 Model Series | Position 2 Center Section | Position 3 Connection | Position 4 Wetted Parts | Position 5 Hardware | Position 6 Seat Material | Position 7 Ball Material | Position 8 Diaphragm Material |
|-------------------------------|---------------------------------|--------------------------|-------------------------------|---|---|--|--|
| PW10 - Standard Pump | A - Aluminum | A - NPTF Thread | A - Aluminum | P - Plated Steel S - Stainless Steel | A - Santoprene® C - Hytrel® F - Aluminum G - Nitrile | A - Santoprene® C - Hytrel® G - Nitrile T - PTFE V - Viton | A - Santoprene® C - Hytrel® G - Nitrile T - PTFE/ Santoprene® V - Viton |

Accessories

Service Repair Kits | 637397 (air motor)
637401-XX (fluid section)

ARO Station

SPECIALTY PUMP

The ARO® Station is a customized solution with piping and a durable housing that is ready to house an ARO® pump. It offers the ability to capture spills and fumes during chemical transfer from one container to another.

The ARO® Station can accommodate three different sized pumps – the 1", 1-1/2" or 2" Expert Series (EXP) ARO® diaphragm pump. With the capability to pump material from 20 to 132 gallons per minute (500 lpm), the ARO® Station can be calibrated to pump the appropriate quantity for each application. Use of the ARO® Station increases the safety of chemical installations during the unloading process by reducing risks of water hammer that occur during the pressurization of the tanks.

- Made of high-density polyethylene that is impervious to corrosion.
- Drip collection tray that holds up to 39.6 gal (150 liters).
- Free-standing or can be equipped with wheels for mobility.
- Standardized skid size. Overall dimensions:
47.25" (1200mm) length x 31.5" (800mm) width x 48.5" (1230mm) height when case is closed.

ARO offers three add-ons to increase environmental and operator safety:

- A leak detector that communicates possible leakage, helping to minimize air pollution and risk from fumes.
- A heater to prevent freezing in extreme situations.
- An alarm that monitors the level of liquid in the tank and whether the system is running dry.

ARO Station - Closed Cover



ARO Station with field-supplied pump – Cover Open

| Description | Material | Weight lbs (kg) |
|---|-------------|-----------------|
| ARO® Station empty cabinet with EPHD +plates | PEHD Plates | 176.3 (80) |
| ARO® Station Cabinet Configured for 1" Polypropylene Side Flanged EXP Pumps | PVC-U EPDM | 228.6 (103.7) |
| ARO® Station Cabinet Configured for 1" PVDF Side Flanged EXP Pumps | PVDF VITON | 228.6 (103.7) |
| ARO® Station Cabinet Configured for 1-1/2" Polypropylene Side Flanged EXP Pumps | PVC-U EPDM | 228.6 (103.7) |
| ARO® Station Cabinet Configured for 1-1/2" PVDF Side Flanged EXP Pumps | PVDF VITON | 228.6 (103.7) |
| ARO® Station Cabinet Configured for 2" Polypropylene Side Flanged EXP Pumps | PVC-U EPDM | 228.6 (103.7) |
| ARO® Station Cabinet Configured for 2" PVDF Side Flanged EXP Pumps | PVDF VITON | 228.6 (103.7) |
| ARO® Station Leak Detection Option | | N/A |
| ARO® Station Heating System Option | | N/A |
| ARO® Station Alarm Kit Option | | N/A |

Note: Pumps are not included and need to be purchased separately.
Please direct all inquiries to your ARO® Technical support team.

Automatic DeWatering System

SPECIALTY PUMP

Air Operated Control Solution with Liquid Level Sensing

The ARO® Automatic Dewatering System offers automatic on/off controls for Pro and EXP diaphragm pumps. A pneumatically controlled Liquid Level Sensor is used to easily control the fluid level within a desired range. The Automatic Dewatering System will limit the monitoring labor and reduce air consumption by avoiding dry running of the pump.

- Simple design is easy to setup and use.
- All pneumatic operation eliminates electrical ignition source.
- High/Low level control maintains fluid between established levels.
- Reduces air consumption by avoiding pump dry running.
- Portable system with directly mounted liquid level sensor.

SPECIFICATIONS

| | |
|---|-------------------|
| Temperature Range- °F (°C) | 32 – 122 (0 - 50) |
| Air Supply Pressure- psi (bar) | 29-101 (2-7) |
| Weight w/o Pump lbs (kg) | 11 (4.8) |
| Air Connection Size | Rc 3/4" |
| Sensing Tube lengths - ft (m) | 66 (20) |
| Sensitivity to detect liquid level- in (cm) | 2-4 (5-10) |

SERVICE KITS

| | |
|-----------|-----------------------------|
| SS-BQG550 | Mounting Bracket |
| PNCV-1/2 | Pneumatic Controlled Valve |
| 637523 | Sensing Tube and Screen Kit |

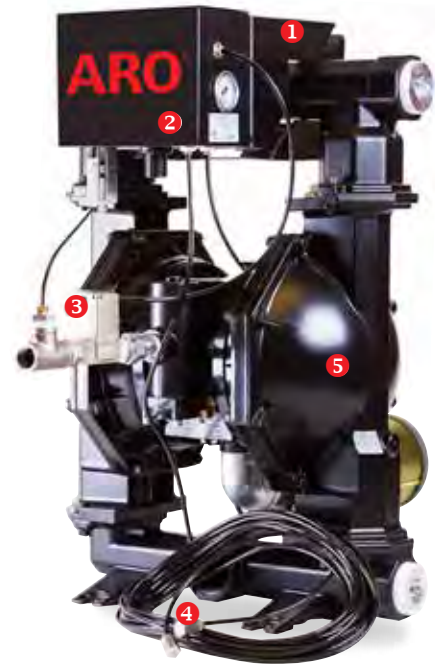

- ❶ Bracket
- ❷ Liquid Level Sensor
- ❸ Pneumatic Controlled Valve
- ❹ Sensing Tubes with Screen
- ❺ Pro/EXP Series Diaphragm Pump (purchase separately)

AUTOMATIC DEWATERING SYSTEM

| | |
|----------------|-------------------------------|
| SCD501BN08-V1D | Dewatering Kit (without pump) |
|----------------|-------------------------------|

PUMP COMPATIBILITY

| | |
|--------------------|----------------------------------|
| 2" EXP Series Pump | PX20X-XXX-XXX-X, PX20P-FXS-XXX |
| 3" EXP Series Pump | PX30X-AXX-XXX-X, PX30X-BXX-XXX-X |

Working Principle

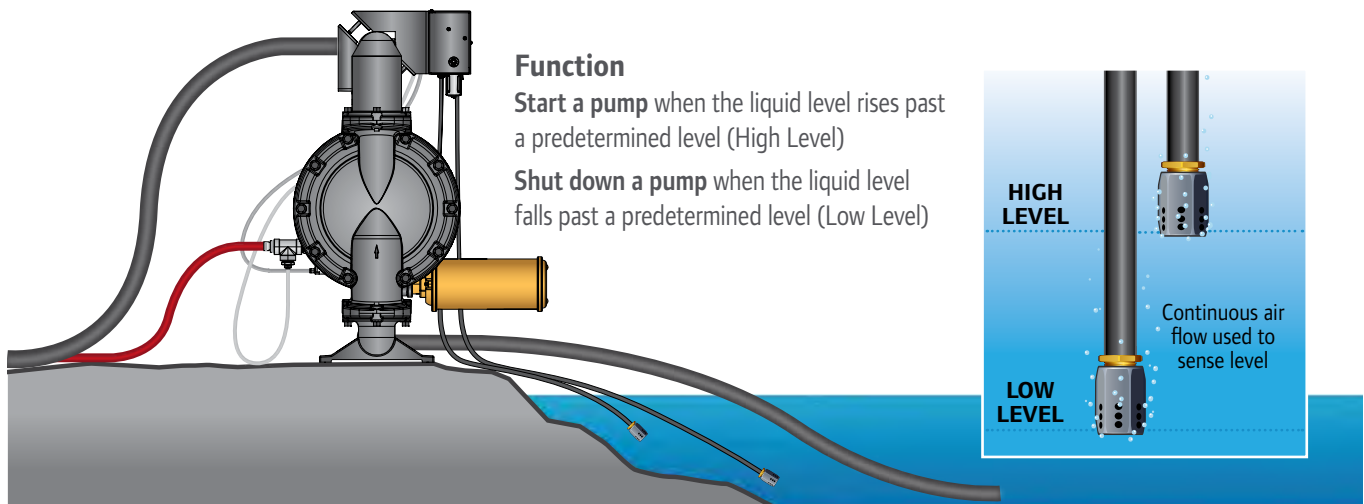

Drum Pumps

SPECIALTY PUMP

Drum Pumps

- Choose from Aluminum, Stainless Steel or Polypropylene body construction - ARO® Drum Pumps are available in three body materials for optimum fluid compatibility.

| | |
|-----------------------------|---|
| Ratio: | 1:1 |
| Maximum Flow: | 11-g.p.m. (41.6-l.p.m.) |
| Displacement per cycle: | .039-Gallons (.15-Liters) |
| Air Inlet: (Female) | 1/4 -18 N.P.T. |
| Fluid Inlet: | Siphon Tube for 55-Gallon Drum |
| Fluid Outlet: | 1/2 -14 N.P.T.F. - 1 |
| Max. operating pressure: | 100-psi (6.8-bar) |
| Suspended solids max. dia.: | 3/32-in. (2.4-mm) |
| Shipping Weight: lbs (kg) | 22 (10) Polypropylene, basic package 26 (11.8) Aluminum, basic package 36 (16.3) Stainless, basic package |

Drum Pump Packages

- Package Components Factory-Matched - ARO® Drum Pump package components contain pre-specified, matching materials of construction for complete fluid compatibility.
- Choose from Basic to Complete - Drum Pump Packages can be ordered in 3 styles:
- Basic: Pump, Bung Adapter, Air Safety Shut-Off, Siphon Tube, Weather Seal and base
- Complete/Transfer: Basic Pump plus Fluid Hose or Fluid Hose with Non-Drip Nozzle
- Complete/Dispensing: Basic Pump plus Foot Valve, Hose and Dispensing Nozzle

Ordering

| Model Number | Pump Housing and Seats | Pump Dia. and Balls | Lock Out Valve (P/N 104253-2) | Foot Valve | 10' Hose ASM | Dispense Valve | Fluid Service |
|----------------|------------------------|---------------------|-------------------------------|------------|--------------------|----------------|-------------------|
| DAB05-PPTT-2-A | POLYPROPYLENE | PTFE | X | - | - | - | ACIDS & CAUSTICS |
| DAB05-PPCC-2-A | POLYPROPYLENE | HYTREL® | X | - | - | - | OIL |
| DAB05-PPUU-2-A | POLYPROPYLENE | POLYURETHANE | X | - | - | - | WATER/OIL |
| DAB05-PPAA-2-A | POLYPROPYLENE | SANTOPRENE® | X | - | - | - | MILD ACIDS/MILD |
| DAB05-PPCC-2-N | POLYPROPYLENE | HYTREL® | X | - | NITRILE | - | OIL |
| DAB05-PPCC-B-M | POLYPROPYLENE | HYTREL® | X | X | NITRILE | NO-DRIP | OIL |
| DAB05-PPAA-2-B | POLYPROPYLENE | SANTOPRENE® | X | - | EPDM | - | MILD ACIDS/MILD |
| DAB05-PPUU-2-C | POLYPROPYLENE | POLYURETHANE | X | - | VINYL | - | WATER/OIL |
| DAB05-PPCC-B-J | POLYPROPYLENE | HYTREL® | X | X | REINFORCED NITRILE | X | OIL |
| DAB05-PPAA-B-K | POLYPROPYLENE | SANTOPRENE® | X | X | EPDM | X | MILD ACIDS/MILD |
| DAB05-SSTT-2-A | STAINLESS STEEL | PTFE | X | - | - | - | SOLVENT |
| DAB05-ASTT-2-A | ALUM./SS. | PTFE | X | - | - | - | SOLVENT |
| DAB05-APCC-2-A | ALUM./POLY. | HYTREL® | X | - | - | - | OIL/SOME SOLVENTS |
| DAB05-APCC-2-O | ALUM./POLY. | HYTREL® | X | - | NITRILE | - | OIL/SOME SOLVENTS |
| DAB05-APCC-B-P | ALUM./POLY. | HYTREL® | X | X | NITRILE | NO-DRIP | OIL/SOME SOLVENTS |
| DAB05-APCC-B-L | ALUM./POLY. | HYTREL® | X | X | REINFORCED NITRILE | X | OIL/SOME SOLVENTS |
| DAB05-ASAA-2-A | ALUM./S.S. | SANTOPRENE® | X | - | - | - | WATER |



Pump Features

- 11-g.p.m. Flow Capability - Drum Pumps offer plenty of capacity to satisfy a broad range of transfer application volume demands.
- Stall-Free Operation - ARO® Diaphragm Drum Pumps feature a patented “unbalanced” air valve design that avoids stall-out, even under low air-inlet pressures.
- Bolted Construction - ARO® Diaphragm Drum Pumps utilize bolted fasteners for leak-tight integrity.
- 5-Year Warranty

Accessories

Air Line Connection Kit | 66073-1

Service Repair Kit | 637458 (air), 637427-XX (fluid), 104255 (for repair of P29122-600 piggyback filter/regulator)

Accessories



Air Line Connection Kit
66073-1



Diaphragm Failure Detection
67237



Cycle Counter Kit
67350



Continuous Duty Muffler
67323



Flange Connection Kit
637341-E10N



Over-run Control
635040

| * Please note pumps are not included with these kits. | 1/4" Non-Met. | 3/8" Non-Met. | 1/2" Non-Met. | 1/2" Classic Non-Met. | 3/4" Non-Met. | 1/2" Metallic | 3/4" Metallic |
|--|--|--|--|---|--|---|--|
| Air Line Connection Kit Kit includes Piggyback Filter/Regulator with gauge, pipe nipple and a 5-foot section of air hose. | 66073-1 | 66073-1 | 66073-1 | 66073-1 | 66073-1 | 66073-1 | 66073-1 |
| Leak Detection Provides a warning of diaphragm failure by sensing the presence of liquid in the air chamber of the pump | Reg. Duty: 67237 ATEX, NEC, CEC: 96270-2 (Qty: 2) & 97414 (Qty: 1) | Reg. Duty: 67237 ATEX, NEC, CEC: 96270-2 (Qty: 2) & 97414 (Qty: 1) | Reg. Duty: 67237 ATEX, NEC, CEC: 96270-2 (Qty: 2) & 97414 (Qty: 1) | - | Reg. Duty: 67237 ATEX, NEC, CEC: 96270-2 (Qty: 2) & 97414 (Qty: 1) | Reg. Duty: 67237 ATEX, NEC, CEC: 96270-2 (Qty: 2) & 97414 (Qty: 1) | Reg. Duty: 67237 ATEX, NEC, CEC: 96270-2 (Qty: 2) & 97414 (Qty: 1) |
| Pneumatic Cycle Counter Kit Like the odometer on your car, ARO's cycle counter lets you know how many pump cycles have elapsed so you can be prepared to perform preventive maintenance | - | 66975 | 66975 | - | 66975 | 66975 | 66975 |
| Cycle Sensor Kit For monitoring pump operation. Can be used to monitor cycle rates, preventative maintenance and rough flow rate indication. | Reg. Duty on Body: 24110934 ATEX on Body: 97404 & 97491 NEC, CEC on Body: 97404 & 97412 | Reg. Duty on Major Valve: 67386 Reg. Duty on Body: 97048 ATEX on Body: 97405 & 97491 NEC, CEC on Body: 97405 & 97412 | Reg. Duty on Major Valve: 67386 Reg. Duty on Body: 97053 ATEX on Body: 97406 & 97491 NEC, CEC on Body: 97406 & 97412 | Reg. Duty on Major Valve: 67168 | Reg. Duty on Major Valve: 67386 Reg. Duty on Body: 97053 ATEX on Body: 97406 & 97491 NEC, CEC on Body: 97406 & 97412 | Reg. Duty on Body: 97053 ATEX on Body: 97406 & 97491 NEC, CEC on Body: 97406 & 97412 | Reg. Duty on Body: 97053 ATEX on Body: 97406 & 97491 NEC, CEC on Body: 97406 & 97412 |
| Continuous-Duty Muffler Recommended for continuous-duty and high-flow applications. Muffler features large expansion chamber, permitting cold exhaust air to exit pump. | - | - | - | - | - | - | - |
| Flange Connection Kit Use with non-metallic EXP pumps with the flange manifold option. Flange kits meet DIN / A.N.S.I. specifications. Flange constructed of glass-filled polypropylene. Bolts, washers and nuts are stainless steel. (Gaskets included) | - | - | - | - | - | - | - |
| Over-run Control Shuts off pump when excessive cycling occurs due to empty fluid supply container. | - | - | 635040 | 635040 | 635040 | 635040 | 635040 |
| Wall Mount Conveniently mount pump above container. Made of heavy gauge coated steel. (pump not included) * Does not include hardware | - | 67388 | 76763 | - | 76763 | 76763 | 76763 |
| Countdown Batcher Manual start batch counter kit controls the volume of fluid dispensed by controlling the number of pump cycles. (pump not included) | - | 67072 | 67072 | - | 67072 | 67072 | 67072 |
| Solenoid Actuation Kit Control pump cycle rate with on/off signal from PLC or other device. Kit includes connector w/36" cable plus components and instructions to install on standard pump. For dosing and batching applications. | - | 67165-1 (24VDC) 67165-2 (120VAC) | 67165-1 (24VDC) 67165-2 (120VAC) | 67165-1 (24VDC) 67165-2 (120VAC) | - | 67165-1 (24VDC) for PD05R-X-X-B 67165-2 (120VAC) for PD05R-X-X-B | - |
| Diaphragm Pump Speed Controls Controls air volume supplied to pump, thus permitting operator to control speed of pump. Can be panel mounted. Composite body. | 104104-N02 | 104104-N02 | 104104-N02 | 104104-N02 | 104104-N02 | 104104-N02 | 104104-N02 |

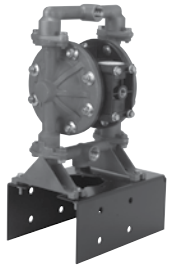

Wall Mount
76763

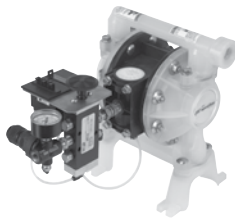

Countdown Batcher
67072



Solenoid Actuation Kit
67165-1



Speed Control
104104-N02



Groundable Strap
66885-1

| 1" Non-Met. | 1-1/2" Non-Met. | 2" Non-Met. | 1" Metallic | 1-1/2" Metallic | 2" Metallic | 3" Metallic | 1" 3:1 Ratio |
|---|---|---|---|---|---|---|--------------|
| 66073-2 | 66084-1 | 66109 | 66073-2 | 66084-1 | 66109 | 66109 | - |
| Reg. Duty: 67237 ATEX, NEC, CEC: 96270-2 (Qty: 2) & 97414 (Qty: 1) | Reg. Duty: 67237 ATEX, NEC, CEC: 96270-2 (Qty: 2) & 97414 (Qty: 1) | Reg. Duty: 67237 ATEX, NEC, CEC: 96270-2 (Qty: 2) & 97414 (Qty: 1) | Reg. Duty: 67237 ATEX, NEC, CEC: 96270-2 (Qty: 2) & 97414 (Qty: 1) | Reg. Duty: 67237 ATEX, NEC, CEC: 96270-2 (Qty: 2) & 97414 (Qty: 1) | Reg. Duty: 67237 ATEX, NEC, CEC: 96270-2 (Qty: 2) & 97414 (Qty: 1) | Reg. Duty: 67237 ATEX, NEC, CEC: 96270-2 (Qty: 2) & 97414 (Qty: 1) | - |
| 67350 | 67350 | 67350 | 67350 | 67350 | 67350-1 | 67350-1 | - |
| Reg. Duty on Major Valve: 67390 Reg. Duty on Body: 97119 ATEX on Body: 97408 & 97491 NEC,CEC on Body: 97408 & 97412 | Reg. Duty on Major Valve: 67390 Reg. Duty on Body: 97396 ATEX on Body: 97410 & 97491 NEC,CEC on Body: 97410 & 97412 | Reg. Duty on Major Valve: 67391 Reg. Duty on Body: 97121 ATEX on Body: 97411 & 97491 NEC,CEC on Body: 97411 & 97412 | Reg. Duty on Major Valve: 67392 Reg. Duty on Body: 97119 ATEX on Body: 97408 & 97491 NEC,CEC on Body: 97408 & 97412 | Reg. Duty on Major Valve: 67392 Reg. Duty on Body: 97396 ATEX on Body: 97410 & 97491 NEC,CEC on Body: 97410 & 97412 | Reg. Duty on Major Valve: 67393 Reg. Duty on Body: 97396 ATEX on Body: 97410 & 97491 NEC,CEC on Body: 97410 & 97412 | Reg. Duty on Major Valve: 67393 Reg. Duty on Body: 97396 ATEX on Body: 97410 & 97491 NEC,CEC on Body: 97410 & 97412 | - |
| - | - | 67323 | - | - | 67263 | 67263 | - |
| 67341-E10N (Side flange) 67341-C10N (Center flange) | 67341-E15N (Side flange) 67341-C15N (Center flange) | 67341-E20N | - | - | - | - | - |
| 635040 | 23644-400 | 23644-400 | 635040 | 23644-400 | 23644-400 | 635043 | - |
| - | - | - | 66100 | 62133 | - | - | 67142 |
| 67072 | 67072-1 | 67072-1 | 67072 | 67072-1 | - | - | - |
| 67355-1 (24VDC) for PE10X-X-X 67355-2 (120VAC) for PE10X-X-X | - | 67355-1 (24VDC) for PE20X-X-X-B 67355-2 (120VAC) for PE20X-X-X-B | 67355-1 (24VDC) for PE10X-X-X 67355-2 (120VAC) for PE10X-X-X | - | - | 67357-1 (24VDC) PE30X-X-X-C 67357-2 (120VAC) PE30X-X-X-C | - |
| 104104-N02 | 104104-N04 | 104104-N04 | 104104-N02 | 104104-N04 | 104104-N06 | 104104-N06 | - |

Accessories

Air Filter/Regulator

➤ The ARO-FLO Series units extend the life of air operated equipment while reducing operating costs. These units efficiently remove solid particles from compressed air lines - making them the great choice for large flow applications.



P39224-614



P39124-600

Piggyback Filter/Regulator, Metal Bowl w/ Sight Glass, Auto Drain

| Pump Size | NPT Model Number | Port Size | Max Inlet Pressure (psi) | Pressure Range (psi) | Max CFM | Micron Element | Size HxWxD (inches) |
|--------------|------------------|-----------|--------------------------|----------------------|---------|----------------|---------------------|
| 1/4" to 3/4" | P39124-624 | 1/4" | 250 | 0-140 | 47 | 5 | 6.9 x 2.9 x 2.9 |
| 1" | P39224-614 | 1/4" | 250 | 0-140 | 72 | 5 | 9.0 x 2.2 x 3.2 |
| 1-1/2" | P39344-614 | 1/2" | 250 | 0-140 | 172 | 5 | 10.9 x 2.8 x 3.2 |
| 2" | P39354-614 | 3/4" | 250 | 0-140 | 173 | 5 | 10.9 x 2.8 x 3.2 |
| 3" | P39454-614 | 3/4" | 250 | 0-140 | 236 | 5 | 14.7 x 3.5 x 4.1 |

Piggyback Filter/Regulator, Poly Bowl w/Guard, Manual Drain

| Pump Size | NPT Model Number | Port Size | Max Inlet Pressure (psi) | Pressure Range (psi) | Max CFM | Micron Element | Size HxWxD (inches) |
|--------------|------------------|-----------|--------------------------|----------------------|---------|----------------|---------------------|
| 1/4" to 3/4" | P39124-600 | 1/4" | 150 | 0-140 | 47 | 5 | 6.2 x 2.9 x 2.9 |
| 1" | P39224-600 | 1/4" | 150 | 0-140 | 72 | 5 | 8.1 x 2.2 x 3.2 |
| 1-1/2" | P39344-600 | 1/2" | 150 | 0-140 | 172 | 5 | 10.0 x 2.8 x 3.2 |
| 2" | P39354-600 | 3/4" | 150 | 0-140 | 173 | 5 | 10.9 x 2.8 x 3.2 |

Cautions of the Use of Polycarbonate Plastic Bowls - Use Only with Compressed Air. Filters and lubricators with polycarbonate plastic bowls are specifically designed for compressed air service, and their use with any other fluid (liquid or gas) is a misapplication. Avoid Harmful Substances. Some compressor oils, chemical cleaners, solvents, paints, and fumes will attack plastic bowls and can cause bowl failure. Do not use with or near these materials. Consult the factory with any questions.



Ingersoll Rand attests that ARO®-Flo Series of filters, regulators, lubricators (1000, 1500, 2000, 3000 Series) and select accessories are out of scope for ATEX Directive 94/9/EEC or 2014/34/EU. The products listed in IRITS-1215-197 certificate can be used in group II, category 2 environment; Gas and Dust with temperature a T6 (Ex II 2GD T6) if all conditions set up in the Instruction Manual are met. Instruction Manuals and certificate regarding ATEX Declaration can be found at AROZONE.COM

Air Control Actuation Valves

3-way valve controls air supply to pump. Activation starts pump, deactivation cuts off air supply to pump and exhausts air from motor, which prevents stalling.

MQ3728-120-A for 1/2" and 1" pumps,

H2545S-120-A for 1-1/2" pumps,

MQ3729-120-A for 2" and 3" pumps

24 VDC MQ3728-024-D for 1/2" and 1" pumps

H2545S-024-D for 1-1/2" pumps

MQ3729-024-D for 2" and 3" pumps



MQ3728-120-A used on 1/2" and 1" pumps

Accessories

Siphon Tubes

For use when pumping from a 55 GAL (200 L) container; siphon tubes are available in PVC, carbon steel, or 316 stainless steel. 1" siphon tubes come with foot valve for positive priming. All models include bung adapter.

| Model no. | Description | For use with pumps |
|-----------|--------------------------------------|--------------------|
| 65109 | Steel — NPT(F) | 1" (Metallic) |
| 66568 | Stainless steel — NPT(F) | 1" (Metallic) |
| 66568 | Stainless steel filter & Siphon tube | 1" (Non-Metallic) |
| 66779 | PVC — NPT(F) | 1" (Non-Metallic) |



Material Agitators

Agitators available for both 5 GAL (20 L) and 55 GAL (200 L) containers. Air operated agitator motors generate between 500-1000 RPM 5 GAL (20 L), and 500-3000 RPM (for 55 GAL, 200 L). Agitator shaft and propellers are constructed of corrosion resistant 316 stainless steel.

| Model no. | For drum | Mounting | Power | Motor speed | Propeller dia. | Axle length |
|-----------|----------------|----------|---------|----------------|----------------|---------------|
| 651100 | 5 GAL (20 L) | 1 | 0.33 hp | 500 - 1000 rpm | 4" (102 mm) | 12"(305 mm) |
| 651103 | 55 GAL (200 L) | 2 | 0.75 hp | 500 - 3000 rpm | 5" (127 mm) | 32.6"(830 mm) |
| 651104-1 | 55 GAL (200 L) | 1 | 0.95 hp | 500 - 3000 rpm | 5" (127 mm) | 32.6"(830 mm) |
| 651104-3 | 5 GAL (20 L) | 1 | 0.75 hp | 500 - 3000 rpm | 5" (127 mm) | 10.5"(267 mm) |

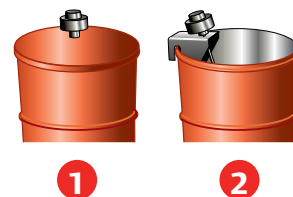

Drum Covers

Durable stainless steel and carbon steel drum covers, accommodate the use of both diaphragm pump and agitator where you need.

| Model no. | For drum | Material | For use with agitator: |
|-----------|----------------|-----------------|------------------------|
| 66971 | 5 GAL (20 L) | Stainless steel | 651100 |
| 66197 | 55 GAL (200 L) | Carbon steel | 651104-1 |
| 94422 | 55 GAL (200 L) | Carbon steel | — |



Pneumatic Liquid Level Sensor*

Used to control pump.

59916-1 to sense when fluid exceeds a desired level

59916-2 to sense when fluid falls below a desired level

* 3 or 4- way valve required



Accessories

ARO® Vibration Isolators

Protect your pump installation by reducing vibration. ARO® Vibration Isolators are used for an efficient reduction of mechanical vibration and stress in the mounting system of an air operated diaphragm pump. They are recommended to be used with flexible fluid pipe connectors to isolate the impact of the pump vibration to fixed pipes.

- ✔ Reduces up to 96% of vibration transmitted through the mount.
- ✔ A set of 4 vibration isolators and mounting hardware are included
- ✔ Smart design: different kit sizes depending on pump weight



Vibration Isolator

| Model Number (4 per kit) | CPN | Description (Max. weight of pump with fluid) |
|-----------------------------|-------------|--|
| HSK-20 | 47532069001 | Vibration Isolator Kit 20 KG (44 LB) |
| HSK-40 | 47532069002 | Vibration Isolator Kit 40 KG (88 LB) |
| HSK-70 | 47532069003 | Vibration Isolator Kit 70 KG (154 LB) |
| HSK-110 | 47532069004 | Vibration Isolator Kit 110 KG (243 LB) |

Accessories

Pulsation Dampeners

Diaphragm pumps of any type have at least two points in their cycle where they provide no pressure or flow to a process. The unwanted result of this pressure fluctuation can often be material foaming, material pulsation, hydraulic shock or material splashing. While traditional pulsation dampeners can help reduce unwanted pulsation and other problems, they also require operator intervention and adjustments.



Automatic Shock Blockers®

- Automatic Air Adjustment - compensates for fluctuations in fluid pressure without operator intervention.
- Significant Pulsation Reduction - Shock Blockers deliver an average 60% - 80% pulsation reduction in high back pressure applications.
- Built for high-flow/aggressive fluid applications - the 2" models can handle up to 2.6 L maximum fluid volume, and 3" models up to 8.3 L maximum fluid volume.
- Broad Material Range for Compatibility - choose from Kynar®, polypropylene, groundable acetal (1" models) or aluminum, cast iron or stainless steel (2" and 3" models) body materials for optimum pump-to-pulsation dampener compatibility.
- Broad Diaphragm/Bladder Fluid Compatibility - choose from Santoprene, Nitrile, PTFE, Hytrel, Viton or Urethane for optimum fluid-to-diaphragm compatibility.
- Perfect for Process Applications - pulsation reduction in long piping runs help prevent costly fluid pipe and downstream valve damage.
- Bolted construction - for leak-free vessel integrity and a safer work-site.
- Ultra-Rugged Construction for long service life - both inside and out, the Shock Blockers are built tough to deliver worry-free, near pulse-free fluid handling.

Typical system

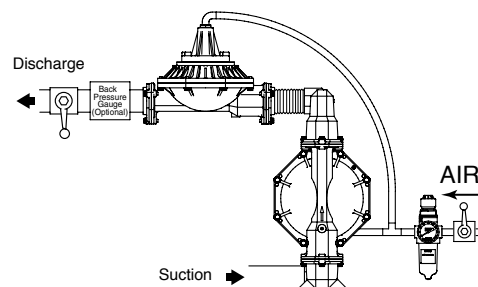
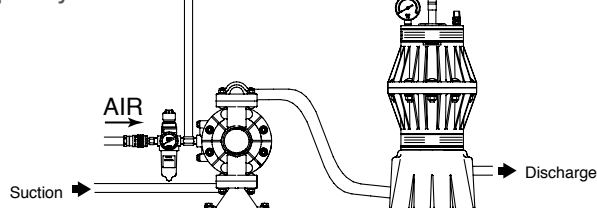

Ordering

| Position | 1 | 2 | | 3 | 4 | 5 | | 6 |
|----------|------|---|---|---|---|---|---|---|
| Example: | SBX0 | X | - | X | X | S | - | X |

| Position 1 Model and Size | Position 2 Air Section | Position 3 Fluid Connection | Position 4 Fluid Section | Position 5 Hardware | Position 6 Diaphragm Material |
|---------------------------------|--|---|--|---|---|
| SB10 - 1" | P - Polypropylene K - PVDF (Kynar) D - Conductive Acetal | A - NPTF B - BSP | P - Polypropylene K - PVDF (Kynar) D - Conductive Acetal | S - Stainless Steel 304 | A - Santoprene® C - Hytrel® T - PTFE U - Urethane |
| SB20 - 2" SB30 - 3" | A - Aluminum C - Cast Iron S - Stainless Steel | 2" A - 2-11-1/2 NPTF-1 B - Rp 2 (2-11 BSP, parallel) 3" A - 3-8-1/2 NPTF-1 B - Rp 3 (3-11 BSP, parallel) | A - Aluminum C - Cast Iron S - Stainless Steel | P - Carbon Steel S - Stainless Steel 304 | A - Santoprene® G - Nitrile T - PTFE / Santoprene® V - Viton |

Maintenance Kits



| Pump type | Models | Air Motor Section | Fluid Section | One Piece Diaphragms | Major Air Valve Assembly |
|--------------------------|---|-------------------|------------------|----------------------|--------------------------|
| 3/8" Non-Metallic | PD03P, PE03P | 637428 | 637429-XX | — | — |
| Non-Metallic | PD05P, PE05P | 637428 | 637427-XX | — | — |
| 1/2" Metallic | PM05P | 637389 | 637375-XX | — | — |
| | PD05A, PD05R, PE05A, PE05R | 637428 | 637427-XX | — | — |
| 3/4" Non-Metallic | PD07P | 637428 | 637427-XX | — | — |
| Metallic | PD07R | 637428 | 637427-XX | — | — |
| Non-Metallic | PD10P, PE10P, PD10E, PE10E | 637397 | 637396-XX | — | 637395-X |
| 1" Metallic | PD10A, PD10R, PD10S, PE10A, PE10R, PE10S, PM10A, PM10R, PM10S | 637397 | 637401-XX | — | 637395-X |
| | PH10A-XSS-SST | 637338 | 637339 | — | — |
| | SD10S | 637495 | 637493-XX | — | 637496 |
| Non-Metallic | PD15P, PE15P, PD15E, PE15E | 637389 | 637391-XX | — | 637390-X |
| 1 1/2" Metallic | PD15A, PD15R, PD15S, PE15A, PE15R, PE15S, PM15A, PM15R, PM15S | 637389 | 637375-XX | — | 637390-X |
| Non-Metallic | PD20P, PE20P, PD20E, PE20E | 637369 | 637373-XX | — | 637374-X |
| 2" Metallic | PD20R, PD20Y, PE20R, PE20Y, PM20R | 637369 | 637309-XX | — | 637374-X |
| | PD20A, PD20S, PE20A, PE20S, PM20A, PM20S, PP20A | 637421 | 637309-XX | — | 637374-X |
| | PF20A, PF20S | 637421 | 637310-XX | — | 637374-X |
| | PF20A | 637421 | 637309-XX | — | — |
| | PF20R, PF20Y | 637369 | 637310-XX | — | 637374-X |
| | SD20S | 637497 | 637494-XX | — | 637498 |
| 3" Metallic | PD30R, PE30R, PM30R | 637369 | 637303-XX | — | 637374-X |
| | PD30A, PD30S, PE30A, PE30S, PP30A, PM30A, PM30S | 637421 | 637303-XX | — | 637374-X |
| | PH30F-X | 637369 | 637441-XX | — | 637374-X |

ARO[®] AUTHENTIC ARO PARTS

Exactly built and designed by ARO[®], Authentic ARO[®] Parts are the only replacement parts you can count on to restore your ARO[®] equipment to the equipment's original performance and quality, while backing up your warranty and ATEX hazardous duty certification.

Why Authentic ARO[®] Parts?

Without Authentic ARO name, it does not carry the ARO[®] promise and runs the risk of subpar chemical, metallurgical, and mechanical properties.

And, only Authentic ARO[®] Parts ensure that our pumps continue to meet the strict requirements for ATEX and CE certifications.



Authentic ARO[®] Parts include:

- Diaphragm Pump Parts and Accessories
- Piston Pump Parts and Accessories
- Lubrication Parts and Accessories
- FRL Parts and Accessories

ARO[®] Long-Life PTFE diaphragms keeps your pumps flowing



- Proven 2 time increase in service life over standard PTFE*
- Made with uniquely formulated PTFE that provides greater flex life
- Same great chemical resistance as conventional PTFE
- Seamless replacement for your existing PTFE diaphragms

*as measured by mean time between failure





About ARO®

ARO® is a worldwide manufacturer of fluid management products that are skillfully engineered to deliver performance and serviceability, allowing success to flow freely in our customers' businesses. That's why ARO is fluid intelligence—the smart choice in fluid management products for industrial operations.

With over an 85-year legacy of premier product performance and service excellence, ARO provides fluid management equipment for customers and industries around the globe, including chemical, manufacturing, energy, pharmaceutical, mining and more.

ARO has the right product to meet our customers' specific needs. We offer air-operated diaphragm pumps, piston pumps and packages, filters, regulators, and lubricators (FRLs), lubrication equipment, and pneumatic valves and cylinders.

ARO®

Distributed by:

www.AROzone.com

arotechsupport@irco.com

youtube.com/aropumps

(800) 495-0276

ARO®

ARO® is a brand of Ingersoll Rand. Ingersoll Rand (NYSE:IR) advances the quality of life by creating comfortable, sustainable and efficient environments. Our people and our family of brands—including Club Car®, Ingersoll Rand®, Thermo King® and Trane®—work together to enhance the quality and comfort of air in homes and buildings; transport and protect food and perishables; and increase industrial productivity and efficiency. We are a \$13 billion global business committed to a world of sustainable progress and enduring results. For more information, visit www.ingersollrand.com.