

GC
service

CE
ALL TOOLS
CONFORM TO
EC DIRECTIVE

Catalog C-13

TOP CAT *Air Tools*

QUALITY TOOLS & PARTS

FULL TECHNICAL SUPPORT

CUSTOM TOOL DESIGN & PRODUCTION

FAST DELIVERY

MADE IN THE U.S.A.



Primary Industries Served

STEEL/IRON FOUNDRY



POPULAR TOOLS



58C Vertical Cup Grinder



400RA Right Angle Type 27 Grinder



400HGE Die Grinder



520H Horizontal CW Grinder



56H Horizontal Type 1 Grinder



400GHD Horizontal Die Grinder

ALUMINUM FOUNDRY



POPULAR TOOLS



400RA Right Angle Sander



300HGE Die Grinder



Belt Sander



300GH Horizontal Die Grinder

Primary Industries Served

LIGHT FABRICATOR



POPULAR TOOLS



300RAD Right Angle Die Grinder



300RA Right Angle Type 27 Grinder



300GH Horizontal Die Grinder



320RA Right Angle Type 27 Grinder



300HGE Die Grinder

HEAVY FABRICATOR



POPULAR TOOLS



54VK Vertical Cup Grinder



400RA Right Angle Type 27 Grinder



400GH Horizontal Die Grinder



400HGE Die Grinder

WORK SAFETY – Safe Installation & Working Healthy Page 3-5

VERTICAL GRINDER/SANDER INFORMATION Page 6

Vertical Grinders for use with Type 27, Type 27 Cut-Off (Type 42) & 28 Depressed Center Wheels

	MODEL NUMBER	PAGE NO.
	520V	Page 7
	54V	
	64V	Page 8
	727V <i>Coming Soon!</i>	

Vertical Grinders for use with Type 11 Cup Wheels

	520V	Page 9
	58C	
	68C	Page 10
	711C <i>Coming Soon!</i>	

Pile Cutters for use with Bonded Type 1 Cut-off (Type 41) or Diamond Wheels

	56PC	Page 11
	66PC	

Vertical Sanders for use with Surface Conditioning Abrasives

	520V	Page 12
	56S	

RIGHT ANGLE GRINDER INFORMATION Page 14

Right Angle Grinders for Type 27, Type 27 Cut-Off (Type 42), Type 1 Cut-Off (Type 41) Wheels

	300RA	Page 16
	400RA	
	300RAE	Page 17
	400RAE	
	320RA	Page 18
	420RA	
	520RA	Page 19

RIGHT ANGLE DIE GRINDER INFORMATION Page 20

Right Angle Grinders for Carbide Burrs, Mounted Stones and Surface Conditioning Abrasives

	300RAD	Page 22
	410RAD	
	300RAED	Page 23
	410RAED	
	330RAD	Page 24
	340RAD	

	320RAD	Page 25
	420RAD	
	300VGE	Page 26

RIGHT ANGLE SANDER INFORMATION Page 28

Right Angle Sanders for Surface Conditioning Abrasives

	300RA/307RA	Page 30
	400RA/407RA	
	300RAE/307RAE	Page 31
	400RAE/407RAE	
	330RA6	Page 32
	340RA6	
	320RA6	Page 33
	420RA6	
	3101RA6	Page 34
	4101RA6	
	4520RA/4620RA	Page 35
	520RA	
	300RA(X)M	Page 36
	400RA(X)M/410RA(X)M	
	460RA(X)M	
	300RAE(X)M	Page 37
	400RAE(X)M/410RAE(X)M	

HORIZONTAL GRINDER INFORMATION Page 38

Horizontal Grinders for Type 1 Wheels

	400GH/407GH	Page 40
	507H	
	5201H	Page 41
	56H	
	65H	

Horizontal Grinders for Cone Wheels

	400GH	Page 42
	507H	
	400GH	Page 43
	507H	
	520H	

Horizontal Die Grinders (Collet Output)

	300EH	Page 44
	300GH	

TABLE OF CONTENTS

	400GH	Page 45
	507H	

Geared Horizontal Polishers/Sanders

	300GH(X)M/400GH(X)M	Page 46
	500H1M	

EXTENDED GRINDER INFORMATION

Page 48

Extended Grinders for Burrs, Mounted Stones & 3/8-24 Cone Wheels

	400EH	Page 50
---	-------	---------

Extended Grinders for Burrs, Mounted Stones, 3/8-24 Cone Wheels 5/8-11 Cone Wheels & 4 Inch Type 1 Wheels

	400GEH/407GEH	Page 51
---	---------------	---------

Extended Grinders for 5/8-11 Cone Wheels & 6 Inch Type 1 Wheels

	520HGEH	Page 52
	65HGEH	Page 53
	65NEH	Page 54

HORIZONTAL DIE GRINDER INFORMATION

Page 56

Horizontal Die Grinders (Collet Output)

	300GE/307GE 300HGE/307HGE	Page 58
	400GE 400HGE 400GT	

Horizontal Die Grinders for Type 1, Type 1 Cut-Off & Type 41 Wheels

	400GT 407GT	Page 60
---	----------------	---------

Horizontal Die Grinders for 3/8-24 Cone Wheels

	400GTCW 407GTCW	Page 61
---	--------------------	---------

Geared Horizontal Die Grinders (Collet Output)



	300HGE(X)M 400HGE(X)M	Page 62
---	--------------------------	---------

Geared Horizontal Die Grinders for Surface Conditioning Abrasives

	300GT(X)M 400GT(X)M	Page 63
---	------------------------	---------

AIR DRILLS INFORMATION

Page 64

	300D(X)M 400D(X)M	Page 66
	400D(X)MP	
	500D2M	

	300DRA(X)M 300DRAE(X)M	Page 68
	400DRA(X)M 400DRAE(X)M	
	400FD(X)M	Page 69
	500FD1M	

BELT SANDER

	300BL/K	Page 70
--	---------	---------

BENCH GRINDER

	66BVG	Page 71
--	-------	---------

ABRASIVE CUTTING TOOLS

	65VBW	Page 72
	662VBW	

SCALERS, NEEDLE SCALERS & CHIPPING HAMMERS INFORMATION

Page 74

Scalers

	TC-1 TC-182	Page 75
--	----------------	---------

Needle Scalers

	TC-1 TC-182	Page 76
--	----------------	---------

Chipping Hammers

	80 TC-183	Page 77
--	--------------	---------

MOTORS INFORMATION

Page 78

	300 Series	Page 79
	400 Series	Page 80
	500 Series 520 Series	Page 81
	664 Series	Page 82

SANDING PADS

Page 84

BUSHINGS, COLLETS & ADAPTERS

Page 85

GUARDS

Page 86

MAINTENANCE TOOLS

Page 87

REPAIR KITS

Page 88-89

WARRANTY

Page 90

INDEX

Page 91



TOP
CAT AIR
TOOLS

Work Safety

When care is taken to insure that the right tool is operated properly, and the safety and maintenance procedures are followed, accidents may be avoided.



Read and understand tool manual before work starts to reduce risk of injury to operator, visitors, and tool. Many more guidelines are provided in the tool manual.

Users are responsible for following all established safety codes and regulations such as:

- General Industry Safety & Health Regulations 29 CFR, Part 1910 and, where applicable, Construction Industry Safety & Health Regulations 29 CFR, Part 1929 available from the Superintendent of Documents, Government Printing Office, Washington, D.C. 20402
- Safety Requirements for the Use, Care and Protection of Abrasive Wheels – ANSI B7.1, available from American National Standards Institute, Inc., 1430 Broadway, New York, NY 10018
- Applicable State and Local Regulations.

Personal Protection



Do not use while under the influence of drugs, alcohol or medication. Attention is required to avoid accidents.

Beware of loose hair and clothing so as not to become tangled or trapped during operation.



Eye protection must be worn at all times to prevent particulates from causing eye injury. Eye protection shall conform to ANSI Z87.1.



Ear protection is to be worn when exposure to sound exceeds the limits of applicable Federal, State or local statutes, ordinances or regulations.



Respiratory protection to be used when exposed to contaminants that exceed the applicable threshold limit values required by law.

The following suggestions will help reduce or moderate the effects of repetitive work motion and/or extended vibration exposure:



- 1) Do NOT over-grip the machine/tool. Use only the force required to maintain control.
- 2) Keep hands and body dry and warm. (Blood flow is important—exercise hands and arms as often as necessary).
- 3) Keep wrists as straight as possible. (AVOID hand positions that require the wrist to be flexed, hyper extended or turned side-to-side.
- 4) AVOID anything that may inhibit blood circulation such as smoking tobacco or

prolonged exposure to cold temperatures.

- 5) Do NOT support body-weight on the tool during operation.
- 6) Maintain a stress-free posture for the entire body.

Prolonged exposure to vibrations created by vibrating sources may cause health hazards. There are gloves, handle wraps and other forms of protective measures available to help reduce the hazard. The fit and condition of any vibration abatement measure must be monitored.

Workplace Safety



Pressurized air supply lines and flexible hoses can cause serious injury. Do not use damaged, frayed or deteriorated air hoses and fittings.

The workplace should be clear of hazards and well lit. Dark, cluttered areas make injury more likely

Keep bystanders away while operating a tool. Be aware of the direction of sparks and other grinding and cutting debris.

Make sure that the workpiece is well secured before working. A moving workpiece can cause tools to slip and lead to injury.

Grinder Safety



Machines, attachments and accessories must be used only for the purpose for which they were designed. Do not modify any part of any tool or accessory. Do not use any unapproved accessory.

All tools are designed for use with a pressure of 90 PSI (6.2 Bar) maximum. Excess pressure will cause speed to increase leading to a potential unsafe operating speed.



Inspect the wheel guard for any signs of wear and that it is properly mounted to the tool. Any guard showing signs of wear such as bends, chips, nicks, or cracks shall be replaced.

Verify that the wheel flanges, wheel adapters and spindle threads are correct for the wheel type to be mounted. Only use recommended flanges and wheel adapters. Verify that the guard is correct for the wheel type to be mounted.

Make sure that the tool is in good working order. For example, make sure handles are tight, the spindle bearings are solid—the spindle should not move in and out of the tool when pulled—the flanges are clean and free of nicks and the motor spindle spins freely.

There are a few things that must be checked before using a wheel:

- The rated speed of the grinding wheel and all accessories must equal or exceed the rated speed of the machine. Spinning items too fast may cause them to fail and result in injury.



Inspect wheel for cracks or chips—if found, do not use. Cracks and chips weaken the wheel making a failure more probable

Do not fit a wheel that has been soaked in or exposed to any liquids. Liquids may loosen the bonds of the wheel and lead to failure.

- Wheels without built in threads should fit on spindle but not loose. Loose wheels may be greatly out of balance and cause undue stress on the wheel leading to failure.
- Wheels should be uniform and balanced. Out of balance wheels increase the stress in the wheel and may lead to injury.
- Follow the proper handling and storage of abrasive wheels and inserted tooling as described in ANSI B7.1.



The spindle speed of the tool must be checked. This measured speed shall always be less than the rated speed of the tool. If the tool's speed measures higher than its rated speed it shall be removed from use and corrected before being returned to use.

- Verify that the air line pressure is 90 PSI (6.2 Bar) maximum. Excess pressure will cause speed to increase leading to a potential unsafe operating speed.
- Several speed readings should be taken with the tool being turned on and off between readings. More tests make sure that the tool is reliably reaching the same speed.
- Tachometers must be checked and calibrated on a regular basis according to the manufacturer's recommendations. Precise numbers can only be arrived at by accurate equipment.
- This form of inspection should be made with the grinding wheel or other tooling removed.
- Measure the speed of grinders every 20 hours of actual use or once per week, whichever comes first.
- Measure the speed of grinders after maintenance or repair, whenever a grinder is issued from the tool crib and at each wheel change.



Test a wheel by running the tool under a bench and away from bystanders.

- Run for a minimum of one minute.
- Turn the tool on and off several times.
- This test should be performed any time a wheel may have been pinched, dropped, when the tool is issued or when first using the tool for the day.

Es posible evitar accidentes cuando se tiene cuidado de usar la herramienta correcta de forma adecuada, y se siguen los procedimientos de seguridad y mantenimiento.



Lea y comprenda el manual de la herramienta antes de comenzar a trabajar para reducir el riesgo de lesiones al operario, a los visitantes y a la herramienta. En el manual de la herramienta se proporciona más información.

Los usuarios son responsables de seguir todos los códigos y normativas de seguridad establecidos, como son:

- La normativa de seguridad y salud en la industria general (29 CFR, Parte 1910) y, donde corresponda, la normativa de seguridad y salud en la industria de la construcción (29 CFR, Parte 1929) disponibles en Superintendent of Documents, Government Printing Office, Washington, D.C. 20402
- Los requisitos de seguridad para el Uso, el cuidado y la protección de ruedas abrasivas (ANSI B7.1), disponible en American National Standards Institute, Inc., 1430 Broadway, Nueva York, NY 10018
- Las normativas estatales y locales correspondientes.

Protección personal



No utilizar mientras si ha consumido drogas, alcohol o medicamentos. Se requiere atención para evitar accidentes.

Tenga cuidado con el cabello y la ropa suelta para que no se llegue a enredar o quedar atrapada durante la operación.



Debe usar protectores para los ojos en todo momento para evitar que las partículas causen daños a los ojos. Los protectores de ojos deben ajustarse a la norma ANSI Z87.1.



Debe usar protectores para los oídos cuando la exposición a los ruidos excede los límites de los estatutos, ordenanzas o normativas federales, estatales o locales correspondientes.



Debe usar protección respiratoria cuando se expone a contaminantes que excedan los valores límite que exigen las leyes correspondientes.

Las siguientes sugerencias le ayudarán a reducir o moderar los efectos del movimiento repetitivo en el trabajo y/o la exposición prolongada a la vibración:



1) NO agarre la máquina o herramienta con demasiada fuerza. Aplique únicamente la fuerza necesaria para mantener el control.

2) Mantenga las manos y el cuerpo secos y cálidos. (El flujo sanguíneo es importante; ejercite las manos y los brazos tan a menudo como sea necesario).

3) Mantenga las muñecas tan rectas como sea posible. (EVITE las posiciones de mano que requieren que la muñeca esté doblada, hiperextendida o girada de lado a lado.)

4) EVITE cualquier cosa que pueda inhibir el flujo sanguíneo como son fumar tabaco o la

exposición prolongada a temperaturas frías.

5) NO apoye el peso corporal en la herramienta durante la operación.

6) Mantenga una postura relajada para el cuerpo entero.

La exposición prolongada a las vibraciones creadas por fuentes vibratorias puede causar un riesgo para la salud. Hay guantes, cubiertas de asidero y otras formas de medidas protectoras disponibles para ayudar a reducir el riesgo. Debe vigilar el ajuste y la condición de cualquier medida para la disminución de vibración.

Seguridad en el lugar de trabajo



Las líneas de suministro neumático presurizadas y las mangueras flexibles pueden causar heridas graves. No utilice mangueras y accesorios neumáticos dañados, deshilachados o deteriorados.

El lugar de trabajo debe estar libre de riesgos y bien iluminado. Las áreas oscuras y atestadas aumentan las probabilidades de heridas.

Aleje a los espectadores mientras opera una herramienta. Preste atención a la dirección de las chispas y otros residuos que se producen al moler y cortar.

Asegúrese de que la pieza de trabajo esté bien asegurada antes de trabajar. Una pieza de trabajo móvil puede hacer que la herramienta resbale y conducir a heridas.

Seguridad en el Pulido



Las máquinas, los aditamentos y los accesorios deben ser utilizados únicamente para el propósito para los que fueron diseñados. No modifique ninguna parte de alguna herramienta o accesorio. No utilice

un accesorio que no ha sido previamente aprobado.

Todas las herramientas están diseñadas para usarse a una presión máxima de 90 psi (6.2 Bar). Un exceso en la presión hará que aumente la velocidad, lo cual llevará a una velocidad de operación potencialmente peligrosa.



Inspeccione el guarda de la rueda en cuanto a señales de desgaste y que esté correctamente instalada en la herramienta. La guarda que muestre signos de desgaste como dobleces, despostillamientos, mellas o grietas debe ser reemplazada.

Verifique que las bridas de rueda, los adaptadores de rueda y la rosca del eje sean los correctos para el tipo de rueda que se instalará. Utilice únicamente las bridas y los adaptadores de rueda recomendados. Verifique que la guarda sea la correcta para el tipo de rueda que se instalará.

Compruebe que la herramienta esté funcionando. Por ejemplo, compruebe que los asideros están apretados y los cojinetes de eje están sólidos; que el eje no entre y salga de la herramienta cuando se jala; que las bridas estén limpias y sin mellas y que el eje del motor gire libremente.

Hay algunas cosas que debe revisar antes de utilizar una rueda:

- La velocidad nominal de la rueda de amolar y todos los accesorios debe ser igual o mayor a la velocidad nominal de la máquina. Si los artículos giran demasiado rápido pueden fallar

y resultar en lesiones.



- Inspeccione la rueda en cuanto a grietas o despostillamientos; si encuentra algo, no la utilice. Las grietas y despostillamientos debilitan la rueda haciendo que sea más probable que falle.

- No coloque una rueda que ha sido sumergida o expuesta a algún líquido. Los líquidos pueden aflojar el vínculo de la rueda y conducir a fallas.

- Las ruedas que no tienen rosca deben quedar en el eje pero no quedar sueltas. Las ruedas flojas pueden estar muy desequilibradas y causar una tensión excesiva en la rueda, haciendo que falle.

- Las ruedas deben ser uniformes y equilibradas. Las ruedas desequilibradas aumentan la tensión en la rueda y pueden llevar a lesiones.

- Siga el manejo y almacenamiento adecuados de las ruedas abrasivas y de las herramientas instaladas, como se describe en la norma ANSI B7.1.



La velocidad del eje de la herramienta debe ser verificada. La velocidad medida siempre debe ser menor que la velocidad nominal de la herramienta. Si la velocidad de la herramienta resulta más alta que la velocidad nominal, debe eliminar del uso y corregir el problema antes de que se utilice de nuevo.

- Verifique que la presión máxima de la línea neumática sea de 90 psi (6.2 Bar). Un exceso en la presión hará que aumente la velocidad, lo cual llevará a una velocidad de operación potencialmente peligrosa.

- Debe tomar varias lecturas de la velocidad con la herramienta, encendiendo y apagando la herramienta entre lecturas. Las pruebas adicionales aseguran que la herramienta alcance la misma velocidad de forma confiable.

- Los tacómetros deben ser verificados y calibrados con regularidad según las recomendaciones del fabricante. Únicamente se pueden lograr números precisos con un equipo exacto.

- Realice esta forma de inspección quitando primero la rueda de amolar u otros accesorios.

- Mida la velocidad de los moledores cada 20 horas de uso real o una vez a la semana, lo que sea primero.

- Mida la velocidad de los moledores después de un mantenimiento o reparación, siempre que saque un moedor de la bodega de herramienta o cuando se instale un moedor nuevo.



- Pruebe una rueda haciendo funcionar la herramienta debajo de un banco y lejos de los espectadores.

- Déjala encendida al menos durante un minuto.

- Encienda y apague la herramienta varias veces.

- Realice esta prueba siempre que comprima o deje caer una rueda, cuando utilice la herramienta por primera vez o cuando utilice la herramienta por primera vez en el día.

Conseils de sécurité

Quand on prend soin de s'assurer que le bon outil est utilisé correctement, et que les procédures de sécurité et d'entretien sont respectées, les accidents peuvent être évités.



Lire et comprendre le manuel de l'outil avant le début des travaux pour réduire le risque de blessures pour l'opérateur, les visiteurs, et l'endommagement de l'outil. Beaucoup plus de conseils sont fournis dans le manuel de l'outil.

Les utilisateurs sont tenus de suivre tous les codes de sécurité et les règlements établis tels que:

- General Industry Safety & Health Regulations 29 CFR, Partie 1910 et, le cas échéant, Construction Industry Safety & Health Regulations 29 CFR, Partie 1929, disponible auprès du Superintendent of Documents, Government Printing Office, Washington, D.C. 20402
- Safety Requirements for the Use, Care and Protection of Abrasive Wheels – ANSI B7.1, disponible auprès de American National Standards Institute, Inc., 1430 Broadway, New York, NY 10018
- Règlements locaux et d'État applicables.

Protection individuelle



Ne pas utiliser sous l'influence de drogues, d'alcool ou de médicaments. L'attention est nécessaire pour éviter les accidents.

Méfiez-vous des cheveux et des vêtements trop lâches afin de ne pas vous emmêler ou être piégé pendant le fonctionnement.



Une protection des yeux doit être portée en tout temps pour empêcher les particules de causer des blessures aux yeux. La protection des yeux doivent être conformes à la norme ANSI Z87.1.



Une protection auditive doit être portée lors de l'exposition au bruit dépassant les limites des statuts, ordonnances ou règlements applicables au niveau fédéral, provincial ou local.



Une protection respiratoire doit être utilisée en cas d'exposition à des contaminants qui dépassent les valeurs limites d'exposition applicables prévues par la loi.

Les suggestions suivantes vous permettront de réduire ou d'atténuer les effets du mouvement de tâches répétitives et / ou l'exposition aux vibrations prolongées:



- 1) NE PAS tenir trop fermement la machine ou l'outil. Utilisez juste la force nécessaire pour maintenir le contrôle.
- 2) Garder les mains et le corps sec et chaud. (La circulation du sang est importante - relaxez les mains et les bras aussi souvent que nécessaire).
- 3) Gardez les poignets aussi droits que possible. (ÉVITER les positions de main nécessitent le pliement et une tension excessive du poignet ou le fait de le tourner d'un côté ou de l'autre).
- 4) ÉVITER tout ce qui peut entraver la circulation du sang tel que le tabagisme ou l'exposition prolongée à des températures

froides.

- 5) NE PAS mettre le poids de votre corps sur l'outil pendant l'opération.
- 6) Maintenir une posture sans stress pour le corps tout entier.

Une exposition prolongée aux vibrations créées par des sources de vibration peut provoquer des dangers pour la santé. Il y a des gants, des enveloppements de poignées et d'autres formes de mesures de protection disponibles pour aider à réduire les risques. L'ajustement et la condition de toute mesure de réduction de vibration doivent être surveillés.

Sécurité du lieu de travail



Les conduites d'air sous pression et les tuyaux flexibles peuvent causer des blessures graves. Ne pas utiliser de tuyaux d'air et de raccords endommagés, effilochés ou détériorés.

Le lieu de travail doit être débarrassé de tout risque et bien éclairé. Les zones sombres et encombrées représentent une possibilité plus grande de blessures.

Éloignez les passants lorsqu'on utilise un outil. Soyez conscient de la direction des étincelles et autres débris de meulage et de coupe.

Assurez-vous que la pièce est bien fixée avant de travailler. Une pièce en mouvement peut causer le glissement des outils et provoquer des blessures.

Sécurité concernant les meules



Les machines, équipements et accessoires doivent être utilisés uniquement aux fins pour lesquelles ils ont été conçus. Ne modifier aucune partie de n'importe quel outil ou accessoire. N'utiliser aucun accessoire non approuvé.

Tous les outils sont conçus pour une utilisation sous une pression de 90 psi (6,2 bar) au maximum. Une pression excessive provoque une augmentation de la vitesse, ce qui entraîne une vitesse de fonctionnement potentiellement dangereuse.



Inspecter le carter de protection de la meule pour détecter tout signe d'usure et pour voir s'il est correctement monté sur l'outil. Tout carter de protection montrant des signes d'usure tels que coupes, écaillures, entailles ou fissures doit être remplacé.

Vérifiez que les brides des meules, adaptateurs de meules et filetages de l'axe du moteur sont corrects pour le type de meule qui doit être montée. N'utilisez que les brides et adaptateurs de meule recommandés. Vérifiez que le dispositif de protection est correct pour le type de meule à monter.

Assurez-vous que l'outil est en bon état de fonctionnement. Par exemple, assurez-vous que les poignées sont bien serrées, que les roulements de l'arbre du moteur sont solides: l'axe ne doit pas se déplacer vers l'intérieur ou l'extérieur de l'outil lorsqu'il est tiré, les brides doivent être propres et exempts d'entailles et l'axe du moteur doit tourner librement.

Il y a certaines choses qui doivent être vérifiées avant d'utiliser une meule:

- La vitesse nominale de la meule et tous les accessoires doivent égaux ou dépasser la vitesse nominale de la machine. Faire tourner des pièces trop rapidement peut les faire rater et entraîner des blessures.



- Inspecter la meule pour voir si elle a des fissures ou des copeaux, si vous en trouvez, ne l'utilisez pas. Les fissures et les écaillures affaiblissent la meule, ce qui rend plus probable le ratage de la pièce
- Ne montez pas une meule qui a été trempée dans un liquide ou exposé à un liquide. Les liquides peuvent relâcher les liens de la meule et conduire à l'échec.

- Les meules sans filetage incorporé doivent tenir sur l'axe mais sans être lâche. Les meules libres peuvent être fortement déséquilibrées et causer un stress excessif sur la meule, ce qui conduit à l'échec.

- Les meules doivent être uniformes et équilibrées. Une meule déséquilibrée augmente le stress dans la meule et peut entraîner des blessures.

- Suivre la manutention et l'entreposage des meules abrasives et des outils qui y sont attachés tel que cela est décrit dans la norme ANSI B7.1.



La vitesse de l'axe de l'outil doit être vérifiée. Cette vitesse mesurée est toujours inférieure à la vitesse nominale de l'outil. Si la vitesse de l'outil est supérieure à sa vitesse nominale il doit être retiré de l'utilisation et corrigé avant d'être réutilisé.

- Assurez-vous que la pression de la conduite d'air est de 90 PSI (6,2 bar) maximum. Une pression excessive provoque une augmentation de la vitesse, ce qui conduit à une vitesse de fonctionnement potentiellement dangereux.

- Plusieurs lectures de vitesse doivent être prises alors que l'outil est allumé et éteint entre les lectures. D'autres tests permettent de s'assurer que l'outil est fiable pour atteindre la même vitesse.

- Les compte-tours doivent être vérifiés et étalonnés régulièrement, conformément aux recommandations du fabricant. Les chiffres précis ne peuvent être obtenus qu'avec des équipements précis.

- Ce formulaire d'inspection doit être effectué avec la meule ou autre outillage retiré.

- Mesurer la vitesse des meules toutes les 20 heures d'utilisation réelle ou une fois par semaine, selon ce qui se produit en premier.

- Mesurer la vitesse des meules après un entretien ou une réparation, chaque fois qu'une meule sort de l'armoire à outils et à chaque changement de roue.



- Tester une meule en exécutant l'outil sous un établi et à l'abri des passants.

- faire tourner la meule pendant un minimum d'une minute.

- Mettez en marche et arrêtez la meule plusieurs fois.

- Ce test doit être effectué chaque fois qu'une meule a été pincée, est tombée, lorsque l'outil est délivré ou lors de la première utilisation de l'outil pour la journée.

Vertical Tools

Page Number	Application	Abrasive Size	Model Series	Power Output	Mounting of Abrasives
7	Type 27, Type 27 Cut-Off (Type 42) & 28 Depressed Center Wheels	7 Inch (180 mm)	520V	2 H.P. (1.5 kW)	<p>Type 27 Wheel w/o Hub</p> <p>Wheel Safety Guard, Adapter, Wheel, Adapter Nut, CP-51, CP-52</p>
		7 Inch (180 mm)	54V	3 H.P. (2.3 kW)	
		9 Inch (230 mm)			
8	Type 27 Wheel with Built-in Adapter Type 27 Wheel without Built-in Adapter	7 Inch (180 mm)	64V	4 H.P. (3.0 kW)	
		9 Inch (230 mm)			
		9 Inch (230 mm)	727V	4.3 H.P. (3.2 kW)	
9	Type 11 Cup Wheels	4 Inch (100 mm)	520V	2 H.P. (1.5 kW)	<p>*The use of Wheel Safety Retainers is highly recommended with cup wheels.</p> <p>Wheel Safety Guard, Wheel, Wheel Safety Retainer*</p>
		4 Inch (100 mm)	58C	3 H.P. (2.3 kW)	
		6 Inch (150 mm)			
10	Type 11 Wheel Cup Wheel Maximum Height is 2.0 inches (50mm).	6 Inch (150 mm)	68C	4 H.P. (3.0 kW)	
		6 Inch (150 mm)	711C	4.3 H.P. (3.2 kW)	
11	Type 1 Cut-Off (Type 41) Bonded or Diamond Wheels	8 Inch (200 mm)	56PC	3 H.P. (2.3 kW)	<p>8" or 10" Size Wheels</p> <p>Inner Wheel Flange, Wheel, Wheel Safety Guard, Wheel Nut, Outer Wheel Flange</p> <p>12" or 14" Size Wheels</p> <p>Inner Wheel Flange, Wheel, Wheel Safety Guard, Wheel Nut, Outer Wheel Flange</p>
		10 Inch (250 mm)			
		12 Inch (300 mm)	66PC	4 H.P. (3.0 kW)	
		14 Inch (350 mm)			
12	Surface Conditioning or Sanding Abrasives	7 Inch (180 mm)	520V	2 H.P. (1.5 kW)	<p>Backing Pad, Sanding Pad Nut, Abrasive Disc</p>
		7 Inch (180 mm)	56S	3 H.P. (2.3 kW)	
		9 Inch (230 mm)	56S	3 H.P. (2.3 kW)	

HANDLES

Several different handle styles are offered on our vertical tools. Pictured below are each in detail.

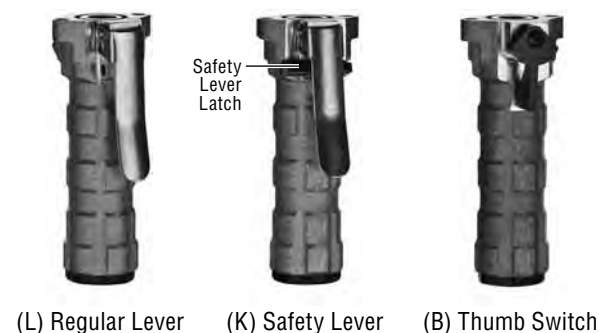

SPEED/GUARD SIZE SELECTION

The rated speed and guard size are closely linked to promote safety and maximize efficiency of the grinding operation. Each model offers various options that are specific to the size/type of the abrasive.

MOUNTING OF ABRASIVES

Each wheel type mounts onto the tool in a specific way. Please consult the diagrams above for details on how your particular wheel mounts onto the tool. More details on the mounting of wheels can be found in ANSI B7.1 and ANSI B186.1. Mounting wheels in ways other than those shown are non-compliant and may lead to injury.



7 Inch • 9 Inch Diameter Wheels
(180 mm) (230 mm)

Vertical Grinders for use with Type 27, Type 27 Cut-Off (Type 42) & 28 Depressed Center Wheels

520V Series



520VK;8000;727

54V Series



54VK;6000;927

Wheel Size	Operating Speed	Lever Style	MODEL NUMBER	Wheel Size	Operating Speed	Lever Style	MODEL NUMBER
7 Inch (180 mm)	8000 RPM	Standard Lever	520VL;8000;727	7 Inch (180 mm)	8000 RPM	Standard Lever	54VL;8000;727
		Safety Lever	520VK;8000;727			Safety Lever	54VK;8000;727
				9 Inch (230 mm)	6000 RPM	Standard Lever	54VL;6000;927
						Safety Lever	54VK;6000;927

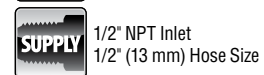
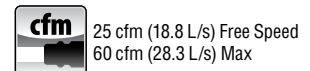
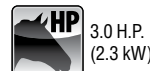
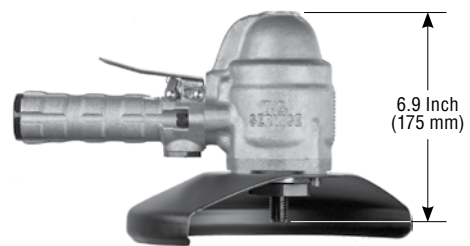
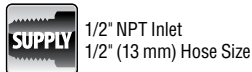
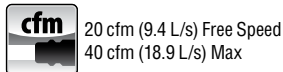
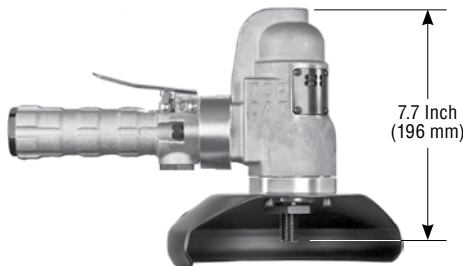

Piped Away Exhaust Available to Reduce Sound Emissions.

STANDARD EQUIPMENT

- Tool
- Operating Instructions and Service Manual
- Wrenches (sizes based on options)

ALTERNATE OPTIONS

Operating Speed



The tools above can be rated at speeds slower than 8000 RPM when used with a 7 Inch (180 mm) wheel.

Handles



WHEEL MOUNTING

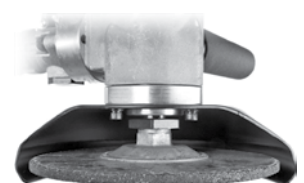

Type 27 or Type 27 Cut-Off (Type 42)

The depressed center wheel adapters are not supplied as standard equipment with the tools. If you are using a wheel that requires the adapters, they must be purchased separately.



Depressed Center Type 27 Wheel



Depressed Center Type 27 Cut-Off (Type 42) Wheel

7 Inch • 9 Inch Diameter Wheels
(180 mm) (230 mm)

Vertical Grinders for use with Type 27, Type 27 Cut-Off (Type 42) & 28 Depressed Center Wheels

64V Series

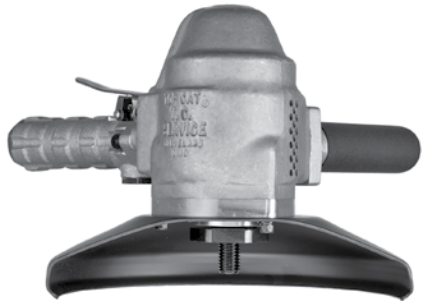

64VK;6000;927

727V Series *Coming Soon!*

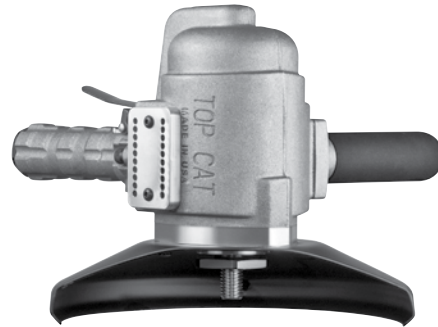

727VK;6000;927

Wheel Size	Operating Speed	Lever Style	MODEL NUMBER	Wheel Size	Operating Speed	Lever Style	MODEL NUMBER
7 Inch (180 mm)	8000 RPM	Standard Lever	64VL;8000;727	9 Inch (230 mm)	6000 RPM	Standard Lever	727VL;6000;927
		Safety Lever	64VK;8000;727				Safety Lever
9 Inch (230 mm)	6000 RPM	Standard Lever	64VL;6000;927			Safety Lever	727VK;6000;927
		Safety Lever	64VK;6000;927				



7.4 Inch (188 mm)

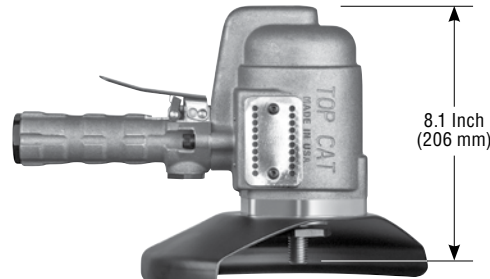

8.1 Inch (206 mm)



4.0 H.P. (3.0 kW)



25 cfm (18.8 L/s) Free Speed
75 cfm (35.4 L/s) Max



11.3 Lbs. (5.1 Kg)



1/2" NPT Inlet
1/2" (13 mm) Hose Size



4.3 H.P. (3.2 kW)



25 cfm (18.8 L/s) Free Speed
85 cfm (40.1 L/s) Max



12.8 Lbs. (5.8 Kg)



1/2" NPT Inlet
1/2" (13 mm) Hose Size



Piped Away Exhaust Available to Reduce Sound Emissions.

STANDARD EQUIPMENT

- Tool
- Operating Instructions and Service Manual
- Wrenches (sizes based on options)

ALTERNATE OPTIONS

Operating Speed



The tools above can be rated at speeds slower than 8000 RPM when used with a 7 Inch (180 mm) wheel.

Handles



Thumb Switch Safety Lever Standard Lever

WHEEL MOUNTING

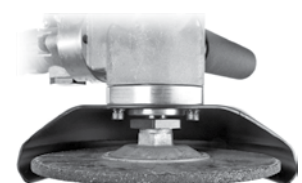

Type 27 or Type 27 Cut-Off (Type 42)

The depressed center wheel adapters are not supplied as standard equipment with the tools. If you are using a wheel that requires the adapters, they must be purchased separately.



Vertical Grinders for use with Type 11 Cup Wheels

520V Series



520VK;8000;411

58C Series

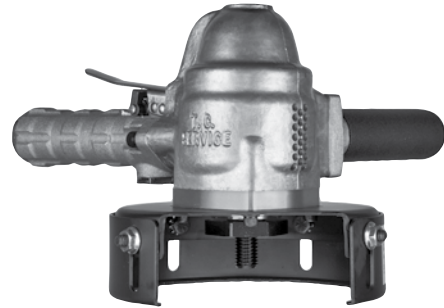

58CK;6000;611

Wheel Size	Operating Speed	Lever Style	MODEL NUMBER	Wheel Size	Operating Speed	Lever Style	MODEL NUMBER
4 Inch (100 mm)	8000 RPM	Standard Lever	520VL;8000;411	4 Inch (100 mm)	8000 RPM	Standard Lever	58CL;8000;411
		Safety Lever	520VK;8000;411			Safety Lever	58CK;8000;411
				6 Inch (150 mm)	6000 RPM	Standard Lever	58CL;6000;611
						Safety Lever	58CK;6000;611

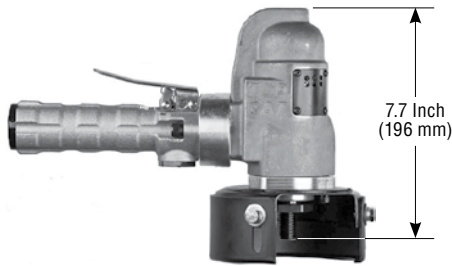

HP 2.0 H.P. (1.5 kW)	cfm 20 cfm (9.4 L/s) Free Speed 40 cfm (18.9 L/s) Max
Lbs 7.5 Lbs. (3.4 Kg)	SUPPLY 1/2" NPT Inlet 1/2" (13 mm) Hose Size

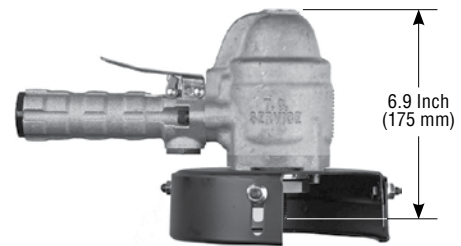

HP 3.0 H.P. (2.3 kW)	cfm 25 cfm (18.8 L/s) Free Speed 60 cfm (28.3 L/s) Max
Lbs 10.3 Lbs. (4.7 Kg)	SUPPLY 1/2" NPT Inlet 1/2" (13 mm) Hose Size



Piped Away Exhaust Available to Reduce Sound Emissions.

STANDARD EQUIPMENT

- Tool
- Operating Instructions and Service Manual
- Wrenches (sizes based on options)

ALTERNATE OPTIONS

Wheel Size

Versions are Available on Model 58C for use with 5 Inch (125 mm) Wheels.

Handles

Thumb Switch Safety Lever Standard Lever

WHEEL MOUNTING

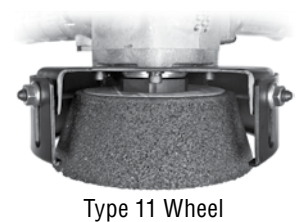



4 Inch • 6 Inch Diameter Wheels
(100 mm) (150 mm)

Vertical Grinders for use with Type 11 Cup Wheels

68C Series

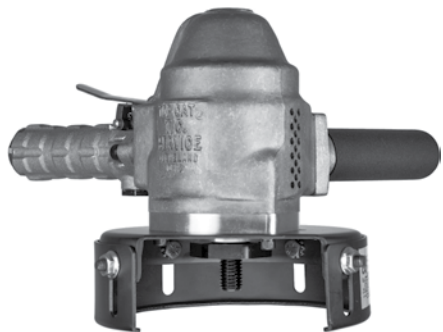

68CK;6000;611

711C Series *Coming Soon!*

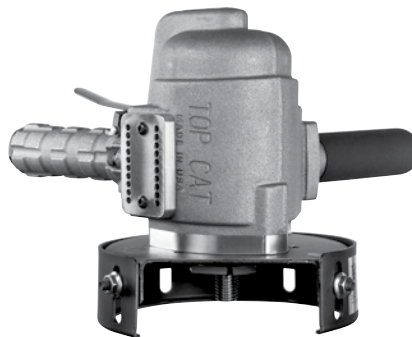

711CK;6000;611

Wheel Size	Operating Speed	Lever Style	MODEL NUMBER	Wheel Size	Operating Speed	Lever Style	MODEL NUMBER
6 Inch (150 mm)	6000 RPM	Standard Lever	68CL;6000;611	6 Inch (150 mm)	6000 RPM	Standard Lever	711CL;6000;611
		Safety Lever	68CK;6000;611			Safety Lever	711CK;6000;611

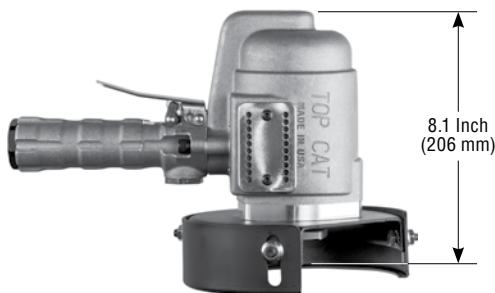

HP 4.0 H.P. (3.0 kW)

cfm 25 cfm (18.8 L/s) Free Speed
75 cfm (35.4 L/s) Max

Lbs 11.8 Lbs. (5.3 Kg)

SUPPLY 1/2" NPT Inlet
1/2" (13 mm) Hose Size

HP 4.3 H.P. (3.2 kW)

cfm 25 cfm (18.8 L/s) Free Speed
85 cfm (40.1 L/s) Max

Lbs 13.3 Lbs. (6.0 Kg)

SUPPLY 1/2" NPT Inlet
1/2" (13 mm) Hose Size



Piped Away Exhaust Available to Reduce Sound Emissions.

STANDARD EQUIPMENT

- Tool
- Operating Instructions and Service Manual
- Wrenches (sizes based on options)

ALTERNATE OPTIONS



Versions are Available on Model 68C for use with 5 Inch (125 mm) Wheels.

Handles



WHEEL MOUNTING



Type 11 Wheel

Pile Cutters for use with Bonded Type 1 Cut-off (Type 41) or Diamond Wheels

56PC Series



56PCK;6000;841

66PC Series



66PCK;4000;1441

Wheel Size	Operating Speed	Lever Style	MODEL NUMBER	Wheel Size	Operating Speed	Lever Style	MODEL NUMBER
8 Inch X 5/8 ID (200 mm)	6000 RPM	Standard Lever	56PCL;6000;841	10 Inch X 5/8 ID (250 mm)	6000 RPM	Standard Lever	66PCL;6000;1041
		Safety Lever	56PCK;6000;841			Safety Lever	66PCK;6000;1041
				12 Inch X 1.0 ID (300 mm)	5000 RPM	Standard Lever	66PCL;5000;1241
						Safety Lever	66PCK;5000;1241
				14 Inch X 1.0 ID (350 mm)	4000 RPM	Standard Lever	66PCL;4000;1441
						Safety Lever	66PCK;4000;1441



HP 3.0 H.P. (2.3 kW)	cfm 25 cfm (18.8 L/s) Free Speed 60 cfm (28.3 L/s) Max
Lbs 11.3 Lbs. (5.1 Kg)	SUPPLY 1/2" NPT Inlet 1/2" (13 mm) Hose Size



HP 4.0 H.P. (3.0 kW)	cfm 25 cfm (18.8 L/s) Free Speed 75 cfm (35.4 L/s) Max
Lbs 15.8 Lbs. (7.2 Kg)	SUPPLY 1/2" NPT Inlet 1/2" (13 mm) Hose Size

STANDARD EQUIPMENT

- Tool
- Operating Instructions and Service Manual
- Wrenches (sizes based on options)

ALTERNATE OPTIONS

Handles



WHEEL MOUNTING



Vertical Sanders for use with Surface Conditioning Abrasives

520V Series



520VK;8000;7SP

56S Series



56SK;6000;7SP

Wheel Size	Operating Speed	Lever Style	MODEL NUMBER	Wheel Size	Operating Speed	Lever Style	MODEL NUMBER
7 Inch (180 mm)	6000 RPM	Standard Lever	520VL;6000;7SP	7 Inch (180 mm)	6000 RPM	Standard Lever	56SL;6000;7SP
		Safety Lever	520VK;6000;7SP			Safety Lever	56SK;6000;7SP
	8000 RPM	Standard Lever	520VL;8000;7SP		8000 RPM	Standard Lever	56SL;8000;7SP
		Safety Lever	520VK;8000;7SP			Safety Lever	56SK;8000;7SP
				9 Inch (230 mm)	6000 RPM	Standard Lever	56SL;6000;9SP
						Safety Lever	56SK;6000;9SP



2.0 H.P.
(1.5 kW)



20 cfm (9.4 L/s) Free Speed
40 cfm (18.9 L/s) Max



6.8 Lbs.
(3.1 Kg)



1/2" NPT Inlet
1/2" (13 mm) Hose Size



3.0 H.P.
(2.3 kW)



25 cfm (18.8 L/s) Free Speed
60 cfm (28.3 L/s) Max



8.8 Lbs.
(4.0 Kg)



1/2" NPT Inlet
1/2" (13 mm) Hose Size

STANDARD EQUIPMENT

- Tool
- Operating Instructions and Service Manual
- Wrenches (sizes based on options)

ALTERNATE OPTIONS

Handles



Thumb Switch Safety Lever Standard Lever





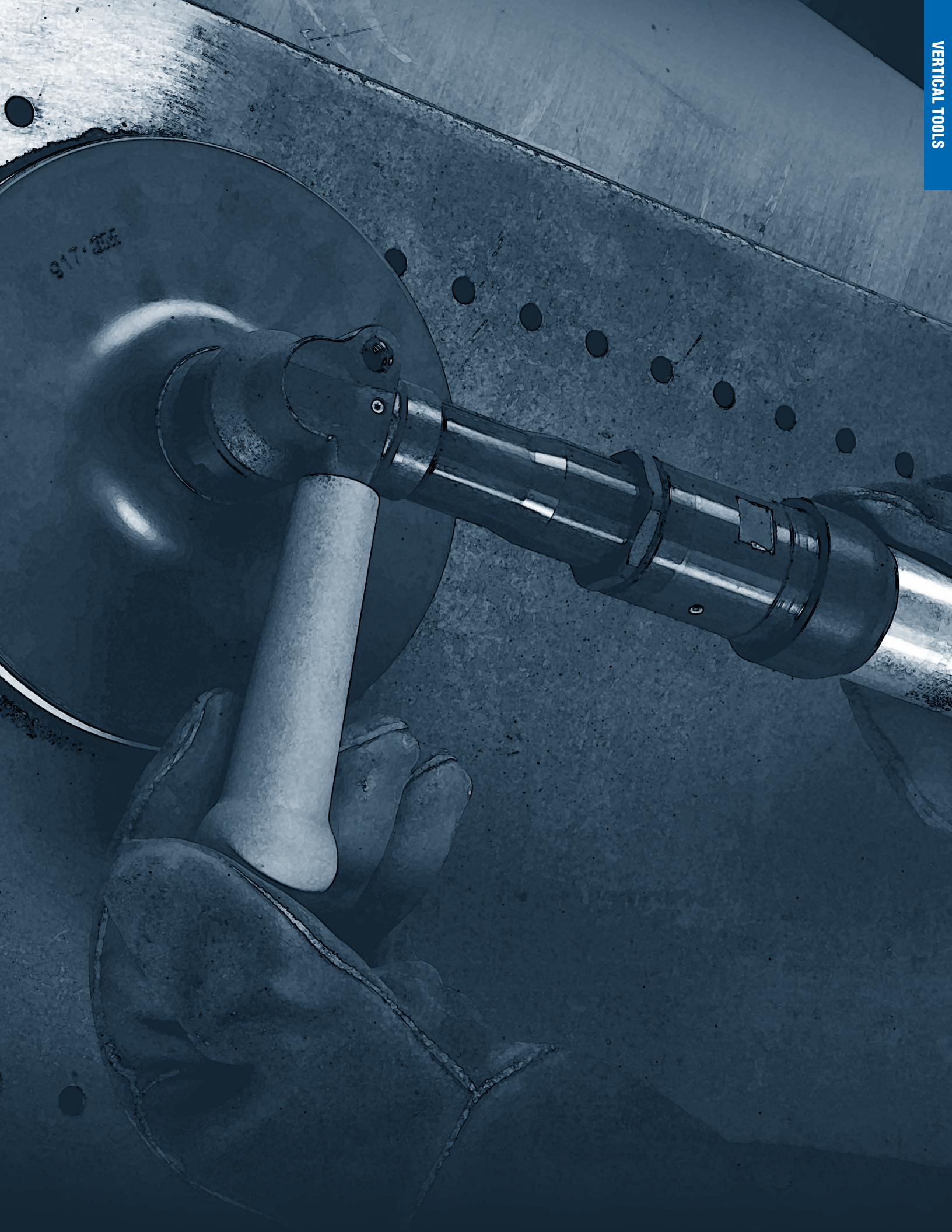

ABRASIVE MOUNTING



Sanding Disc



Right Angle Grinding & Cutting Tools

Application	Page Number	Tool Configuration	Abrasive Size	Model Series	Power Output
 Type 27 Depressed Center Wheels	16	 <ul style="list-style-type: none"> • Large Bearing & Gears for High Duty Cycle & Longevity 	4 Inch (100 mm)	300RA	0.7 H.P. (600 W)
				400RA	1.2 H.P. (900 W)
			4 1/2 Inch (115 mm)	300RA	0.7 H.P. (600 W)
			5 Inch (125 mm)	400RA	1.2 H.P. (900 W)
 Type 1 Cut-off (Type 41) Bonded Wheels	17	 <ul style="list-style-type: none"> • Large Bearing & Gears for High Duty Cycle & Longevity • Extended Neck 	4 Inch (100 mm)	300RAE	0.7 H.P. (600 W)
				400RAE	1.2 H.P. (900 W)
			4 1/2 Inch (115 mm)	300RAE	0.7 H.P. (600 W)
			5 Inch (125 mm)	400RAE	1.2 H.P. (900 W)
	18	 <ul style="list-style-type: none"> • Small Head for Restricted Applications • Extended Neck 	4 Inch (100 mm)	320RA	0.7 H.P. (600 W)
				420RA	1.2 H.P. (900 W)
	19	 <ul style="list-style-type: none"> • Large Head for Larger Size Abrasives 	7 Inch (180 mm)	520RA	2.0 H.P. (1.5 kW)
			9 Inch (230 mm)		
			10 Inch (250 mm)		

LEVER STYLE

Safety Lever Standard Lever

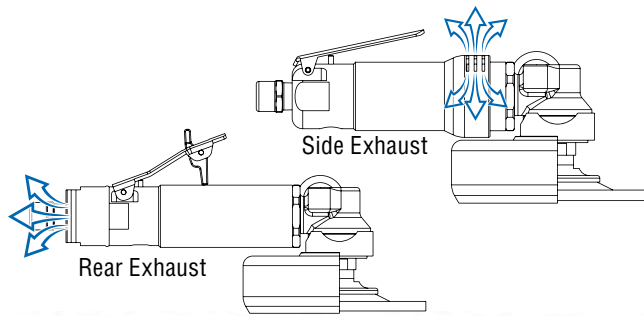
EXHAUST DIRECTION

Rear Exhaust

Side Exhaust

 Rear exhaust overhose for the 300 Series
 Only available on Rear Exhaust tools.

 Rear exhaust overhose for the 400 Series
 Only available on Rear Exhaust tools.

CASE MATERIAL

Aluminum Case Material Steel Case Material

The choice of case material affects the weight and durability of the tool. By its nature, aluminum is lighter in weight than steel. Steel is more durable in aggressive environments.

Extended Neck vs Standard

Extended neck tools allow the operator to reach further into the workpiece. This extended reach coupled with the small heads found on Top Cat tools can allow fine finishing in the tightest of areas. Furthermore, the extended neck tools can be fitted with larger diameter abrasives allowing for more efficient material removal and better, more consistent surface finishes.

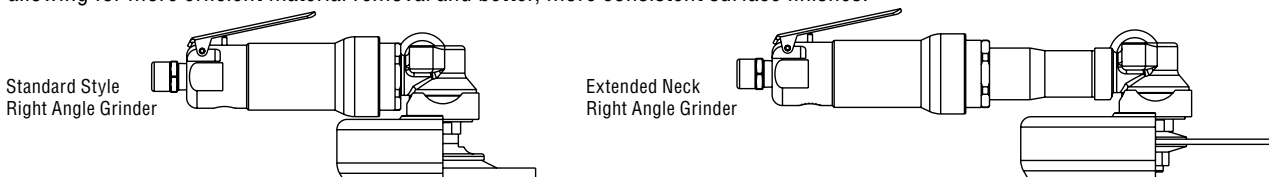

Standard Style Right Angle Grinder

Extended Neck Right Angle Grinder

Right Angle Grinding & Cutting Tools

	3/8-24 x 1.0 Inch Spindle	5/8-11 x 1.0 Inch Spindle	3/8-24 x 0.6 Inch Spindle
Output Thread Size & Length			
Popular Wheel Sizes & Type	<ul style="list-style-type: none"> • 4 Inch Type 27 and Type 27 Cut-Off (Type 42) • 4 Inch Type 1 Cut-off (Type 41) 	<ul style="list-style-type: none"> • 4 1/2 Inch Type 27 and Type 27 Cut-Off (Type 42) • 4 1/2 Inch Type 1 Cut-Off (Type 41) 	4" Type 1 Cut-Off (Type 41)
Optional Wheel Sizes & Type	<ul style="list-style-type: none"> • 4 1/2 Inch Type 27 and Type 27 Cut-Off (Type 42) • 4 1/2 Inch Type 1 Cut-Off (Type 41) • 5 Inch Type 27 and Type 27 Cut-Off (Type 42) • 5 Inch Type 1 Cut-off (Type 41) • 6 Inch Type 1 Cut-off (Type 41) 	<ul style="list-style-type: none"> • 5 Inch Type 27 and Type 27 Cut-Off (Type 42) • 5 Inch Type 1 Cut-off (Type 41) • 6 Inch Type 1 Cut-off (Type 41) 	

Wheel Mounting for Right Angle Grinders

Type 27 and 42 Wheels with 3/8" ID Mounting Hole

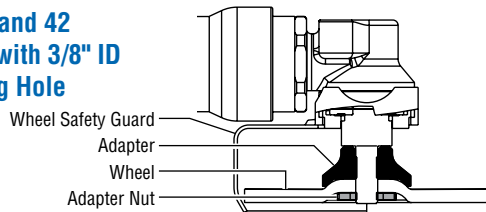

Adapter Set Number	Spindle Size
490-KR	3/8-24 x 0.6 Inch
490-K	3/8-24 x 1.0 Inch

Type 1 Cut-Off (Type 42) Wheels

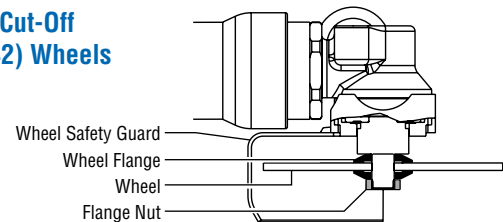

Part Number	Spindle Size	Wheel Mounting Hole
400-G-42	3/8-24	4" or Smaller
1100-682		4-1/2" or Larger
1100-680	5/8-11	

Ordered as individual parts

520RA Type 27 and 42 Wheels

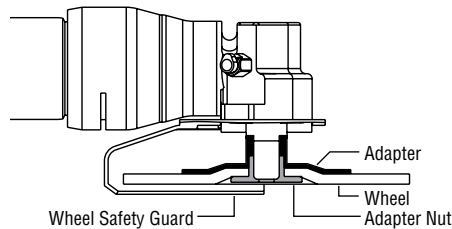

520RA Type 1 Cut-Off (Type 41) Wheels

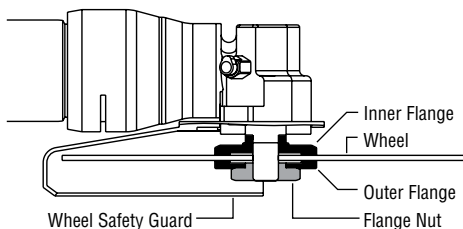

Type 27 and 42 Wheels with 5/8" or 7/8" ID Mounting

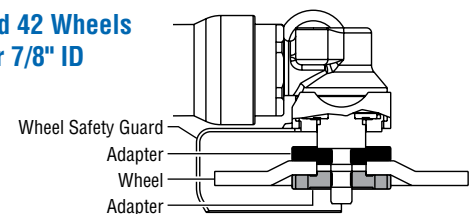

Part Number	Spindle Size	Wheel Mounting Hole
ADT27-354	3/8-24	5/8"
ADT27-375		7/8"
ADT27-575	5/8-11	

Ordered as individual parts

These Adapters can be used to mount either Type 27, Type 27 Cut-Off (Type 42) or Type 1 Cut-Off (Type 41) wheels

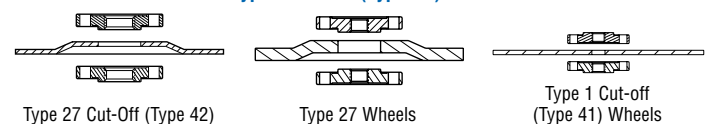

Short Right Angle Grinders for Type 27, Type 27 Cut-Off (Type 42) & Type 1 Cut-Off (Type 41) Wheels

300RA Series

400RA Series



300RA4K;15000;427

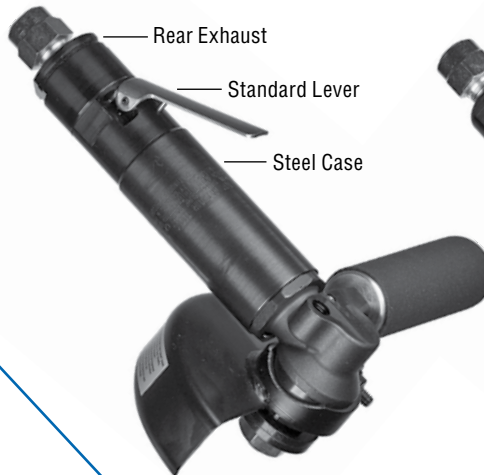

400RA2RS;10000;4527



400RA2SK;10000;4527

Wheel Size	Exhaust Direction	Lever Style	MODEL NUMBER		Wheel Size	Exhaust Direction	Lever Style	MODEL NUMBER		
			Type 27 Wheels (Type 42)	Type 1 or Type 1 Cut-Off Wheels (Type 41)				Type 27 Wheels (Type 42)	Type 1 or Type 1 Cut-Off Wheels (Type 41)	
4 Inch (100 mm)	Rear	Standard Lever	300RA4;15000;427	300RA4;15000;441	4 1/2 Inch (115 mm)	Side	Standard Lever	400RA2S;10000;4527	400RA2S;10000;4541	
		Safety Lever	300RA4K;15000;427	300RA4K;15000;441			Safety Lever	400RA2SK;10000;4527	400RA2SK;10000;4541	
4 1/2 Inch (115 mm)	Rear	Standard Lever	300RA2;13000;4527	300RA2;13000;4541			Rear	Standard Lever	400RA2RS;10000;4527	400RA2RS;10000;4541
		Safety Lever	300RA2K;13000;4527	300RA2K;13000;4541				Safety Lever	400RA2RSK;10000;4527	400RA2RSK;10000;4541

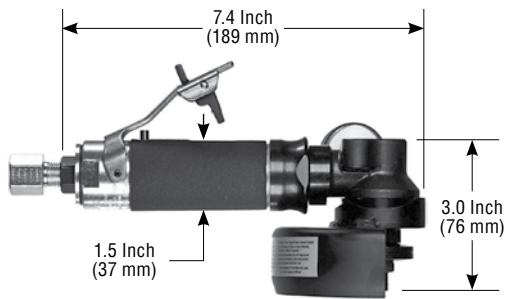

0.7 H.P. (600 W)



25 cfm (11.8 L/s) Max



2.8 Lbs. (1.3 Kg) Aluminum
3.2 Lbs. (1.5 Kg) Steel



1/4" NPT Inlet
3/8" (10 mm) Hose Size

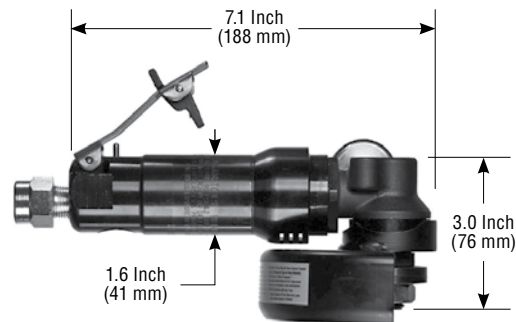

1.2 H.P. (900 W)



35 cfm (16.5 L/s) Max



3.2 Lbs. (1.5 Kg) Aluminum
3.8 Lbs. (1.7 Kg) Steel



3/8" NPT Inlet
1/2" (13 mm) Hose Size

STANDARD EQUIPMENT

- Tool
- Operating Instructions and Service Manual
- Wrenches (sizes based on options)

Wheel Size



Versions are Available for use with 5 Inch (125 mm) Wheels.

300RA Alternate Options

Case Material



Aluminum Case Steel Case

400RA Alternate Options

Case Material



Aluminum Case Steel Case

Wheel Mounting



Type 27 or Type 27 Cut-Off (Type 42) Wheel



Type 1 or Type 1 Cut-Off (Type 41) Wheel

Extended Right Angle Grinders for Type 27, Type 27 Cut-Off (Type 42) & Type 1 Cut-Off (Type 41) Wheels

300RAE Series



300RAE2;13000;4527

400RAE Series

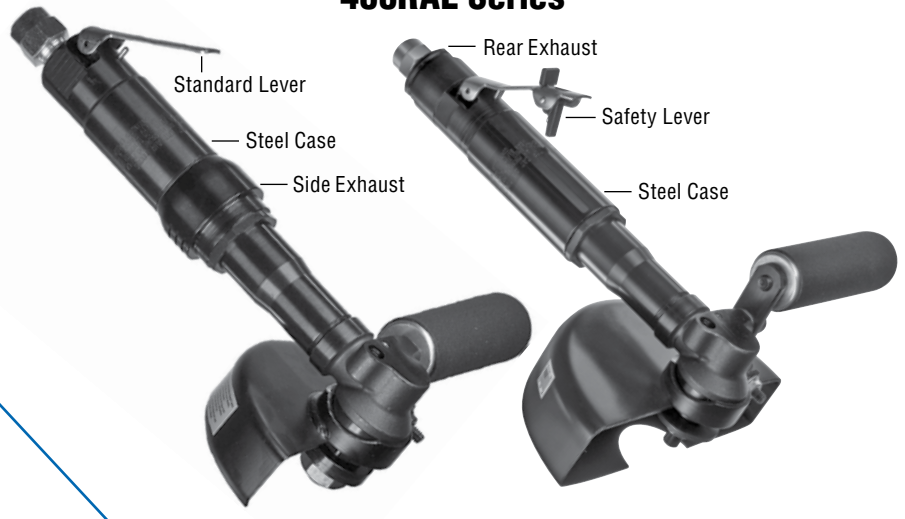

400RAE2S;10000;4527

400RAE2SRK;10000;641

Wheel Size	Exhaust Direction	Lever Style	MODEL NUMBER		Wheel Size	Exhaust Direction	Lever Style	MODEL NUMBER		
			Type 27 Wheels (Type 42)	Type 1 or Type 1 Cut-Off Wheels (Type 41)				Type 27 Wheels (Type 42)	Type 1 or Type 1 Cut-Off Wheels (Type 41)	
4 Inch (100 mm)	Side	Standard Lever	300RAE4;15000;427	300RAE4;15000;441	4 1/2 Inch (115 mm)	Side	Standard Lever	400RAE2S;10000;4527	400RAE2S;10000;4541	
		Safety Lever	300RAE4K;15000;427	300RAE4K;15000;441			Safety Lever	400RAE2SK;10000;4527	400RAE2SK;10000;4541	
	Rear	Standard Lever	300RAE4R;15000;427	300RAE4R;15000;441			Standard Lever	400RAE2SR;10000;4527	400RAE2SR;10000;4541	
		Safety Lever	300RAE4RK;15000;427	300RAE4RK;15000;441			Safety Lever	400RAE2SRK;10000;4527	400RAE2SRK;10000;4541	
4 1/2 Inch (115 mm)	Side	Standard Lever	300RAE2;13000;4527	300RAE2;13000;4541		6 Inch (150 mm) Cut-Off Only	Side	Standard Lever		400RAE2S;10000;641
		Safety Lever	300RAE2K;13000;4527	300RAE2K;13000;4541				Safety Lever		400RAE2SK;10000;641
	Rear	Standard Lever	300RAE2R;13000;4527	300RAE2R;13000;4541				Standard Lever		400RAE2SR;10000;641
		Safety Lever	300RAE2RK;13000;4527	300RAE2RK;13000;4541				Safety Lever		400RAE2SRK;10000;641

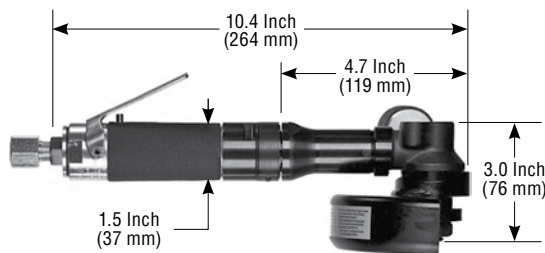

HP 0.7 H.P. (600 W)

cfm 25 cfm (11.8 L/s) Max

Lbs 3.3 Lbs. (1.5 Kg) Aluminum
3.7 Lbs. (1.7 Kg) Steel

SUPPLY 1/4" NPT Inlet
3/8" (10 mm) Hose Size

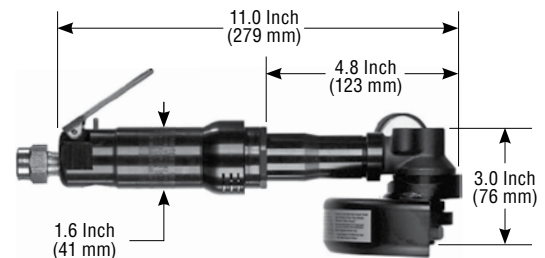

HP 1.2 H.P. (900 W)

cfm 35 cfm (16.5 L/s) Max

Lbs 3.8 Lbs. (1.7 Kg) Aluminum
4.4 Lbs. (2.0 Kg) Steel

SUPPLY 3/8" NPT Inlet
1/2" (13 mm) Hose Size

STANDARD EQUIPMENT

- Tool
- Operating Instructions and Service Manual
- Wrenches (sizes based on options)

Wheel Size



300RAE Alternate Options

Case Material



Aluminum Case Steel Case

400RAE Alternate Options

Case Material



Aluminum Case Steel Case

Wheel Mounting



Type 27 or Type 27 Cut-Off (Type 42) Wheel



Type 1 or Type 1 Cut-Off (Type 41) Wheel

Extended Right Angle Grinders with Small Heads for Type 27 Depressed Center & Type 1 Cut-Off (Type 41) Wheels

320RA Series



320RA4K;15000;441

420RA Series



420RA4RS;13000;427

420RA4SK;13000;441

Wheel Size	Exhaust Direction	Lever Style	MODEL NUMBER		Wheel Size	Exhaust Direction	Lever Style	MODEL NUMBER	
			Type 27 Wheels (Type 42)	Type 1 or Type 1 Cut-Off Wheels (Type 41)				Type 27 Wheels (Type 42)	Type 1 or Type 1 Cut-Off Wheels (Type 41)
4 Inch (100 mm)	Side	Standard Lever	320RA4;15000;427	320RA4;15000;441	4 Inch (100 mm)	Side	Standard Lever	420RA4S;13000;427	420RA4S;13000;441
		Safety Lever	320RA4K;15000;427	320RA4K;15000;441			Safety Lever	420RA4SK;13000;427	420RA4SK;13000;441
	Rear	Standard Lever	320RA4R;15000;427	320RA4R;15000;441		Rear	Standard Lever	420RA4RS;13000;427	420RA4RS;13000;441
		Safety Lever	320RA4RK;15000;427	320RA4RK;15000;441			Safety Lever	420RA4RSK;13000;427	420RA4RSK;13000;441

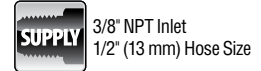
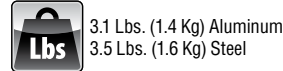
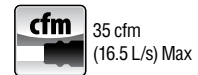
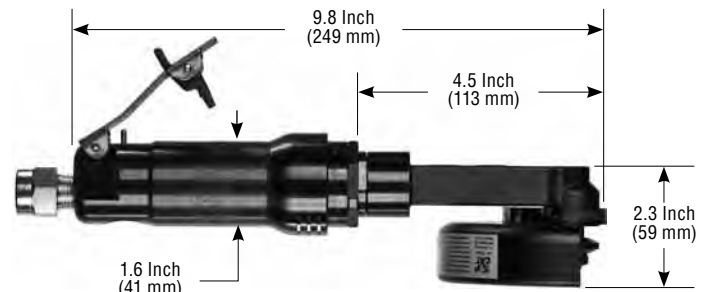
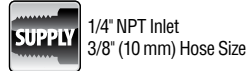
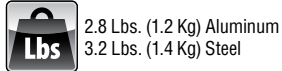
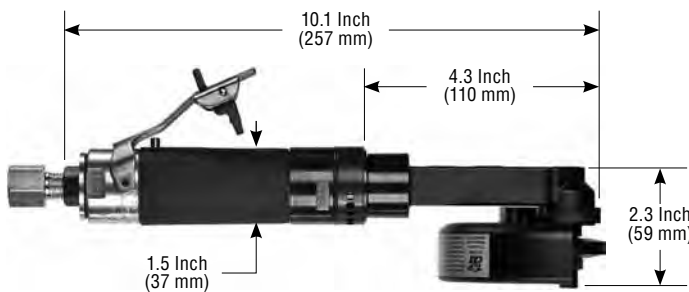

STANDARD EQUIPMENT

- Tool
- Operating Instructions and Service Manual
- Wrenches (sizes based on options)

320RA Alternate Options

Case Material



Aluminum Case Steel Case

420RA Alternate Options

Case Material



Aluminum Case Steel Case

Wheel Mounting

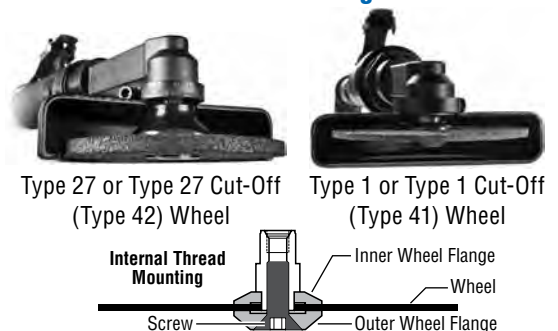

Right Angle Grinders for Type 27, Type 27 Cut-Off (Type 42), Type 1 Cut-Off (Type 41) Wheels

520RA Series



520RAK;8000;727



520RA2L;6000;1041

RIGHT ANGLE GRINDERS

Wheel Size	Exhaust Direction	Lever Style	MODEL NUMBER	
			Type 27 Wheels (Type 42)	Type 1 or Type 1 Cut-Off Wheels (Type 41)
7 Inch (180 mm)	6000 RPM	Standard Lever	520RAL;6000;727	
		Safety Lever	520RAK;6000;727	
	8000 RPM	Standard Lever	520RAL;8000;727	
		Safety Lever	520RAK;8000;727	
9 Inch (230 mm)	6000 RPM	Standard Lever	520RAL;6000;927	
		Safety Lever	520RAK;6000;927	
		Standard Lever	520RAL2;6000;1041	
		Safety Lever	520RAK2;6000;1041	

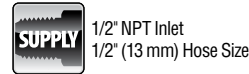
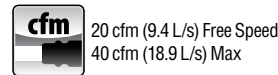
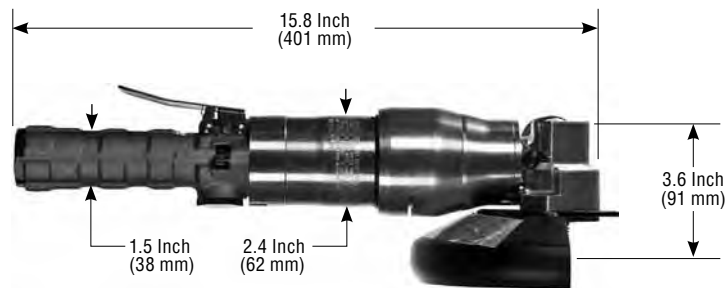
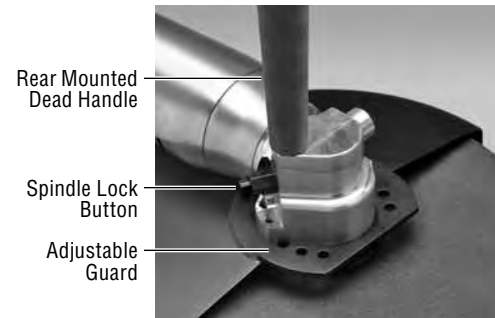

STANDARD EQUIPMENT

- Tool
- Operating Instructions and Service Manual
- Wrenches (sizes based on options)

520RA Alternate Options



Wheel Mounting



The depressed center wheel adapters are not supplied as standard equipment with the tools. If you are using a wheel that requires the adapters, they must be purchased separately.

Right Angle Die Grinders

Page Number	Tool Configuration	Abrasive Size	Model Series	Power Output
22		<ul style="list-style-type: none"> • Large Bearing & Gears for High Duty Cycle & Longevity 	300RAD	0.7 H.P. (600 W)
			410RAD	1.2 H.P. (900 W)
23		<ul style="list-style-type: none"> • Large Bearing & Gears for High Duty Cycle & Longevity • Extended Neck 	300RAED	0.7 H.P. (600 W)
			410RAED	1.2 H.P. (900 W)
24		<ul style="list-style-type: none"> • Small Head for Restricted Applications 	330RAD	0.7 H.P. (600 W)
			340RAD	
25		<ul style="list-style-type: none"> • Small Head for Restricted Applications • Extended Neck 	320RAD	0.7 H.P. (600 W)
			420RAD	1.2 H.P. (900 W)
26		<ul style="list-style-type: none"> • Vertical Motor Design • No Gears 	300VGE	0.7 H.P. (600 W)

LEVER STYLE



Safety Lever Regular Lever

EXHAUST DIRECTION

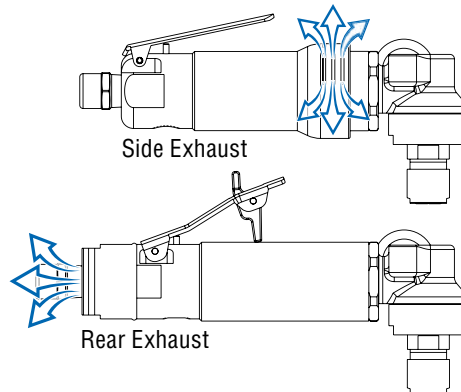

Side Exhaust

Rear Exhaust

CASE MATERIAL



Aluminum Case Material Steel Case Material

The choice of case material affects the weight and durability of the tool. By its nature, aluminum is lighter in weight than steel. Steel is more durable in aggressive environments.



Rear exhaust overhose for the 300 Series
Only available on Rear Exhaust tools.



Rear exhaust overhose for the 400 Series
Only available on Rear Exhaust tools.

Right Angle Die Grinders

1/4 Inch (6 mm) - 3/8 Inch (8 mm) Mandrel Size (3/8 Inch Max.)

1/8 Inch (3 mm) - 1/4 Inch (6 mm) Mandrel Size (1/4 Inch Max.)



- 300RAD/300RAED
- 410RAD/410RAED



- 330RAD/340RAD
- 320RAD/420RAD



Carbide Burrs



Cartridge Roll w/ Rubber Expanding Wheel



Flap Wheels



Mounted Stones



Sandpaper



Surface Finishing/Conditioning Wheels



Cartridge Rolls

Your Abrasive/Mounting Accessory must be rated at higher speeds than the rating on the tools.
Please consult the abrasive manufacturer for proper speed ratings.

Extended Neck vs Standard

The extended neck option helps in regards to clearance issues when using various types of larger surface finishing abrasives. In these instances, the surface finishing abrasive can interfere with the area around the motor case normally used by the operator to grip the tool. The extended neck option moves the surface finishing abrasive forward which clears the area around the motor case for the operators hand.

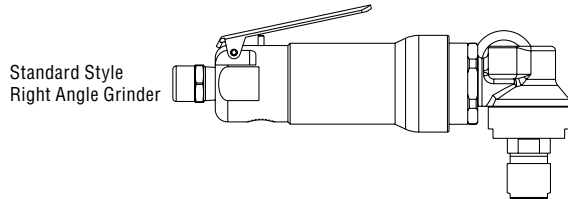

Standard Style Right Angle Grinder

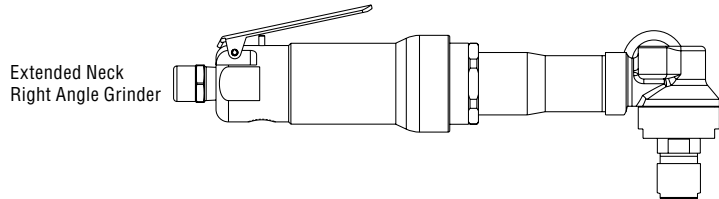

Extended Neck Right Angle Grinder

Inserted Tool Mounting

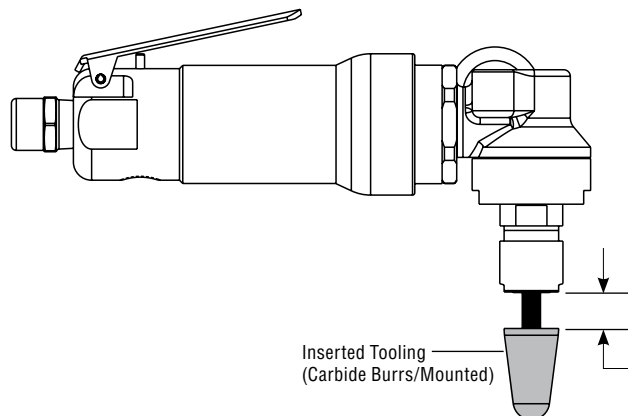

Inserted Tooling (Carbide Burrs/Mounted)

Overhang - 1/2 Inch Max.

Short Right Angle Collet Grinders

300RAD Series



300RADK;15000;1/4

410RAD Series



410RADSK;13000;1/4

410RADRS;13000;1/4

Lever Style	MODEL NUMBER	Exhaust Direction	Lever Style	MODEL NUMBER
Standard Lever	300RAD;15000;1/4	Side	Standard Lever	410RADS;13000;1/4
Safety Lever	300RADK;15000;1/4		Safety Lever	410RADSK;13000;1/4
		Rear	Standard Lever	410RADRS;13000;1/4
			Safety Lever	410RADRSK;13000;1/4

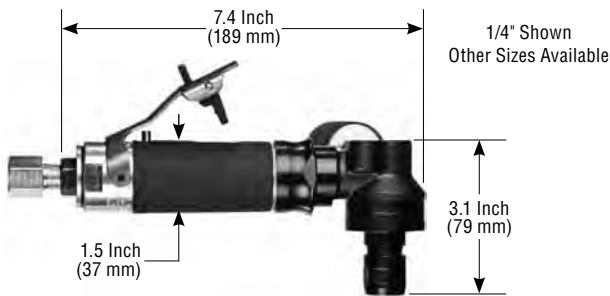

0.7 H.P.
(600 W)



25 cfm
(11.8 L/s) Max



2.2 Lbs. (1.0 Kg) Aluminum
2.8 Lbs. (1.3 Kg) Steel



1/4" NPT Inlet
3/8" (10 mm) Hose Size

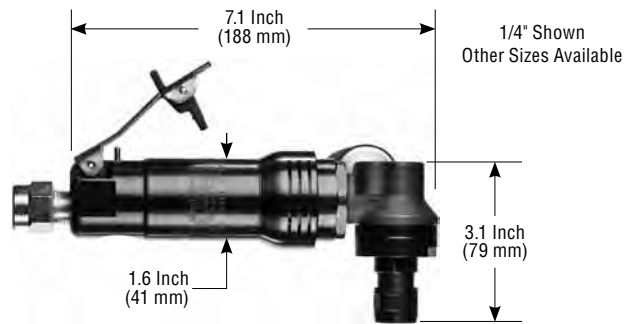

1.2 H.P.
(900 W)



35 cfm
(16.5 L/s) Max



2.6 Lbs. (1.2 Kg) Aluminum
3.2 Lbs. (1.7 Kg) Steel



3/8" NPT Inlet
1/2" (13 mm) Hose Size

STANDARD EQUIPMENT

- Tool
- Operating Instructions and Service Manual
- Wrenches (sizes based on options)



The ER Heavy Duty Collet is Standard Equipment on 300RAD & 410RAD Series.

300RAD Alternate Options

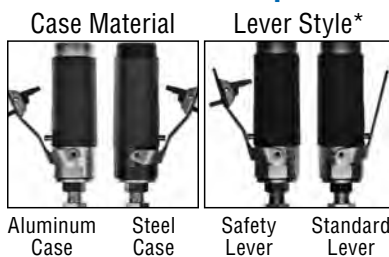

410RAD Alternate Options

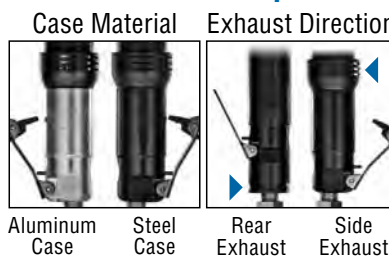

Abrasive Mounting



*APPLIES TO BOTH TOOL SERIES

Extended Neck Right Angle Collet Grinders

300RAED Series



300RAED;15000;1/4

410RAED Series



410RAEDS;13000;1/4

410RAEDRSK;13000;1/4

RIGHT ANGLE GRINDERS

Exhaust Direction	Lever Style	MODEL NUMBER	Exhaust Direction	Lever Style	MODEL NUMBER
Side	Standard Lever	300RAED;15000;1/4	Side	Standard Lever	410RAEDS;13000;1/4
	Safety Lever	300RAEDK;15000;1/4		Safety Lever	410RAEDSK;13000;1/4
Rear	Standard Lever	300RAEDR;15000;1/4	Rear	Standard Lever	410RAEDRS;13000;1/4
	Safety Lever	300RAEDRK;15000;1/4		Safety Lever	410RAEDRSK;13000;1/4

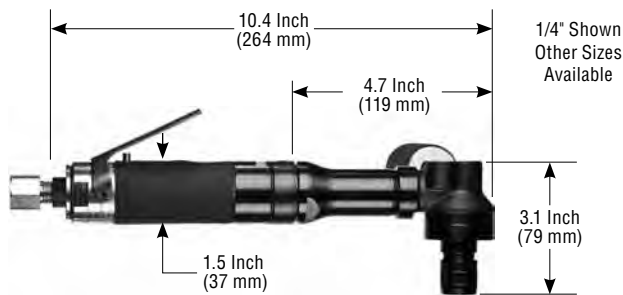

0.7 H.P.
(600 W)



25 cfm
(11.8 L/s) Max



2.7 Lbs. (1.2 Kg) Aluminum
3.1 Lbs. (1.4 Kg) Steel



1/4" NPT Inlet
3/8" (10 mm) Hose Size

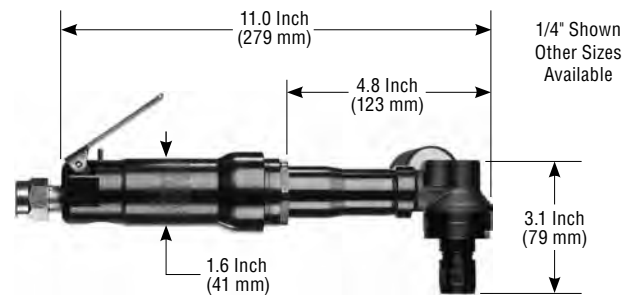

1.2 H.P.
(900 W)



35 cfm
(16.5 L/s) Max



3.2 Lbs. (1.2 Kg) Aluminum
3.8 Lbs. (1.4 Kg) Steel



3/8" NPT Inlet
1/2" (13 mm) Hose Size

STANDARD EQUIPMENT

- Tool
- Operating Instructions and Service Manual
- Wrenches (sizes based on options)



The ER Heavy Duty Collet is Standard Equipment on 300RAED & 410RAED Series.

300RAED Alternate Options

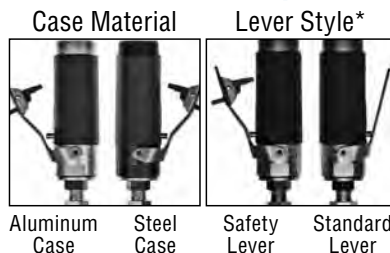

410RAED Alternate Options

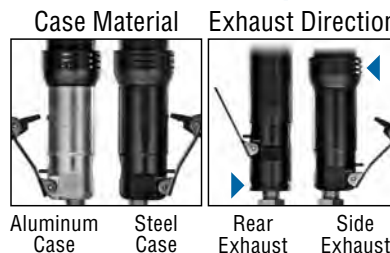

Abrasive Mounting



*APPLIES TO BOTH TOOL SERIES

Short Right Angle Collet Grinders

330RAD/340RAD Series



330RADK;12000;1/4

Maximum Rated Operating Speed	Lever Style	MODEL NUMBER
12,000 RPM	Standard Lever	330RAD;12000;1/4
	Safety Lever	330RADK;12000;1/4
20,000 RPM	Standard Lever	340RAD;20000;1/4
	Safety Lever	340RADK;20000;1/4

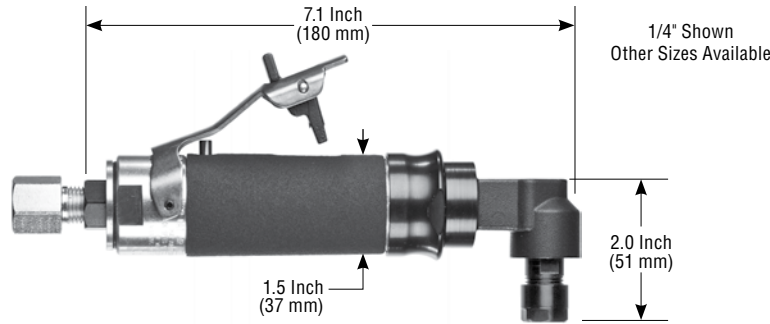

0.7 H.P.
(600 W)



25 cfm
(11.8 L/s) Max



1.6 Lbs. (0.7 Kg) Aluminum
2.0 Lbs. (0.9 Kg) Steel



1/4" NPT Inlet
3/8" (10 mm) Hose Size

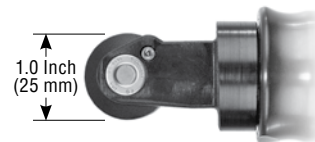

STANDARD EQUIPMENT

- Tool
- Operating Instructions and Service Manual
- Wrenches (sizes based on options)



The ER Heavy Duty Collet is Standard Equipment on 330RAD & 340RAD Series.

330RAD/340RAD Alternate Options

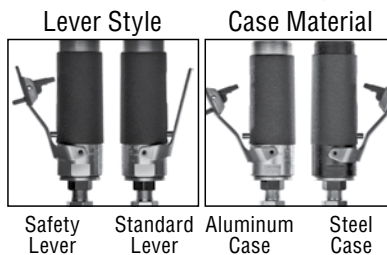

Abrasive Mounting



Extended Right Angle Collet Grinders

320RAD Series



320RADK;20000;1/4

420RAD Series



420RADSK;13000;1/4

420RADRS;13000;1/4

RIGHT ANGLE GRINDERS

Exhaust Direction	Lever Style	MODEL NUMBER	Exhaust Direction	Lever Style	MODEL NUMBER
Side	Standard Lever	320RAD;20000;1/4	Side	Standard Lever	420RADS;13000;1/4
	Safety Lever	320RADK;20000;1/4		Safety Lever	420RADSK;13000;1/4
Rear	Standard Lever	320RADR;20000;1/4	Rear	Standard Lever	420RADRS;13000;1/4
	Safety Lever	320RADRK;20000;1/4		Safety Lever	420RADRSK;13000;1/4

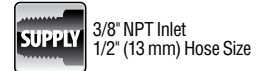
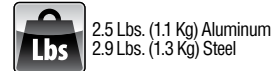
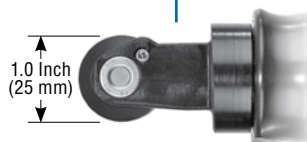
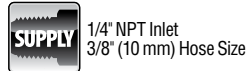
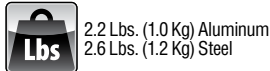
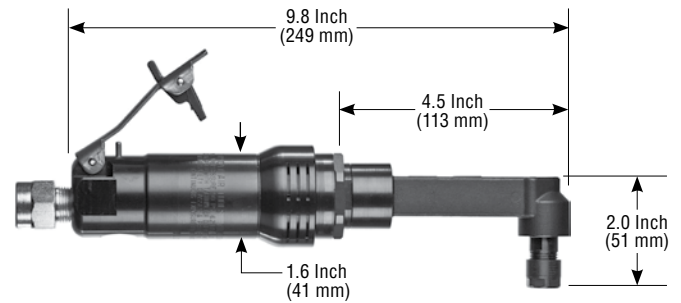
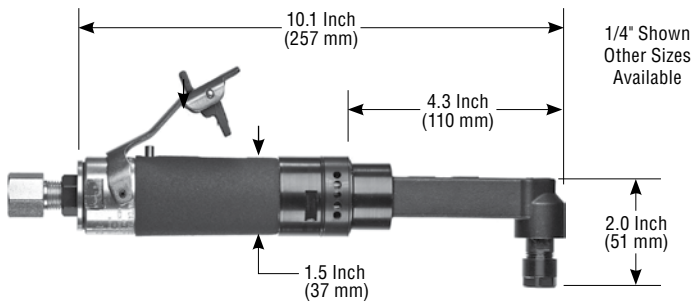

STANDARD EQUIPMENT

- Tool
- Operating Instructions and Service Manual
- Wrenches (sizes based on options)



The ER Heavy Duty Collet is Standard Equipment on 320RAED & 420RAED Series.

320RAD Alternate Options

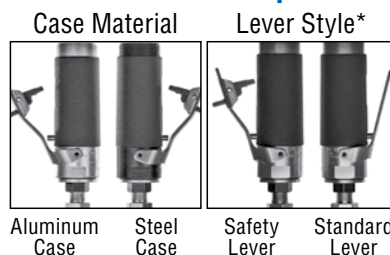

420RAED Alternate Options

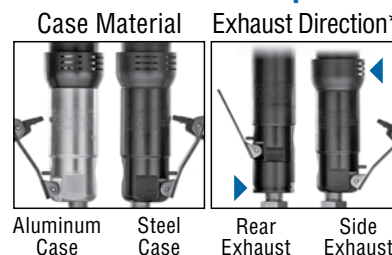

Abrasive Mounting



*APPLIES TO BOTH TOOL SERIES

Vertical Collet Grinders

300VGE Series

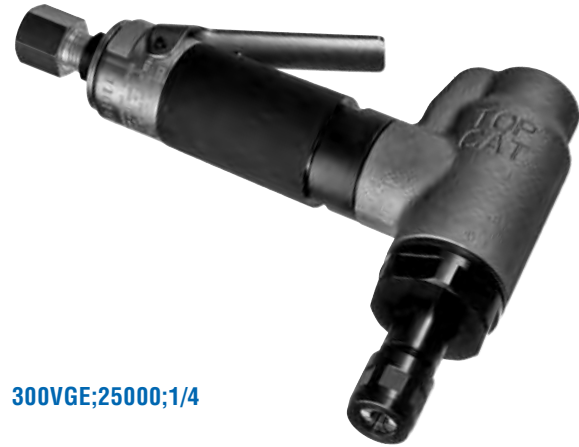

300VGE;25000;1/4

	Maximum Rated Operating Speed	Lever Style	MODEL NUMBER
Double Front Bearing ER Style Insert Collet 3/8 Inch (8 mm) Maximum	30,000 RPM	Standard Lever	300VGE;30000;1/4
		Safety Lever	300VGEK;30000;1/4
	25,000 RPM	Standard Lever	300VGE;25000;1/4
		Safety Lever	300VGEK;25000;1/4
	20,000 RPM	Standard Lever	300VGE;20000;1/4
		Safety Lever	300VGEK;20000;1/4
	18,000 RPM	Standard Lever	300VGE;18000;1/4
		Safety Lever	300VGEK;18000;1/4

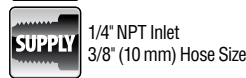
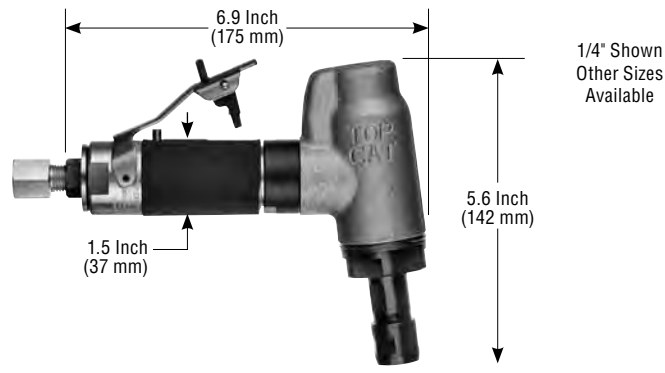

STANDARD EQUIPMENT

- Tool
- Operating Instructions and Service Manual
- Wrenches (sizes based on options)



The ER Heavy Duty Collet is Standard Equipment on 300VGE Series.

300VGE Alternate Options

Lever Style



Safety Lever Standard Lever









Abrasive Mounting





RIGHT ANGLE GRINDERS

Right Angle Sanders, Buffers & Polishers

Surface Conditioning Abrasives	Page Number	Tool Configuration	Abrasive Size	Model Series	Power Output		
 <p>Non-Woven Nylon Web or Convolute Abrasives</p>	30	 <ul style="list-style-type: none"> • Large Bearing & Gears for High Duty Cycle & Longevity 	3 Inch (75 mm)	300RA	0.7 H.P. (600 W)		
			4 Inch (100 mm), 4 1/2 Inch (115 mm) or 5 Inch (125 mm)	307RA 400RA 410RA 407RA		1.2 H.P. (900 W)	
	31	 <ul style="list-style-type: none"> • Large Bearing & Gears for High Duty Cycle & Longevity • Extended Neck 	3 Inch (75 mm)	300RAE	0.7 H.P. (600 W)		
			4 Inch (100 mm), 4 1/2 Inch (115 mm) or 5 Inch (125 mm)	317RAE 307RAE 400RAE 410RAE 407RAE		1.2 H.P. (900 W)	
			32	 <ul style="list-style-type: none"> • Small Head for Restricted Applications 	2 Inch (50 mm)		330RA 340RA
					33	 <ul style="list-style-type: none"> • Small Head for Restricted Applications • Extended Neck 	2 Inch (50 mm)
	420RA	1.2 H.P. (900 W)					
	34	 <ul style="list-style-type: none"> • Extremely Small Head for Restricted Applications • Extended Neck 	2 Inch (50 mm)	3101RA	0.7 H.P. (600 W)		
			4101RA	1.2 H.P. (900 W)			
	35	 <ul style="list-style-type: none"> • Heavy-Duty, Large Head for Longer Life. 	5 Inch (125 mm)	4620RA	1.2 H.P. (900 W)		
7 Inch (180 mm)			4520RA				
520RA			2.0 H.P. (1.5 kW)				
36	 <ul style="list-style-type: none"> • Planetary Gear Systems for Low Speed Applications 	5 Inch (125 mm)	300RA(X)M 310RA(X)M	0.7 H.P. (600 W)			
		7 Inch (180 mm)	400RA(X)M 410RA(X)M 4620RA(X)M		1.2 H.P. (900 W)		
		37	 <ul style="list-style-type: none"> • Planetary Gear Systems for Low Speed Applications • Extended Neck 	5 Inch (125 mm)		300RAE(X)M 310RAE(X)M	0.7 H.P. (600 W)
				7 Inch (180 mm)	400RAE(X)M 410RAE(X)M	1.2 H.P. (900 W)	

LEVER STYLE

Safety Lever Regular Lever

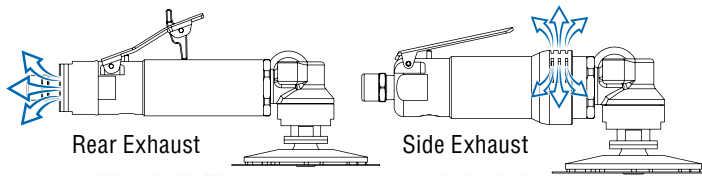
EXHAUST DIRECTION

Rear Exhaust

Side Exhaust



Rear exhaust overhose for the 300 Series
Only available on Rear Exhaust tools.



Rear exhaust overhose for the 400 Series
Only available on Rear Exhaust tools.

CASE MATERIAL

Aluminum Case Material Steel Case Material

The choice of case material affects the weight and durability of the tool. By its nature, aluminum is lighter in weight than steel. Steel is more durable in aggressive environments.

Right Angle Sanders, Buffers & Polishers

	3/8-24 x 1.0 Inch Spindle	5/8-11 x 1.0 Inch Spindle	1/4-20 X 1/2 Inch Spindle
Output Thread Size & Length			
Popular Sanding Pad Sizes	<ul style="list-style-type: none"> • 4 Inch 	<ul style="list-style-type: none"> • 5 Inch • 7 Inch 	<ul style="list-style-type: none"> • 2 Inch • 3 Inch
Optional Sanding Pad Sizes	<ul style="list-style-type: none"> • 5 Inch 	<ul style="list-style-type: none"> • 4 Inch 	

Extended Neck vs Standard

Extended neck tools allow the operator to reach further into the workpiece. This extended reach coupled with the small heads found on Top Cat tools can allow fine finishing in the tightest of areas. Furthermore, the extended neck tools can be fitted with larger diameter abrasives allowing for more efficient material removal and better, more consistent surface finishes.

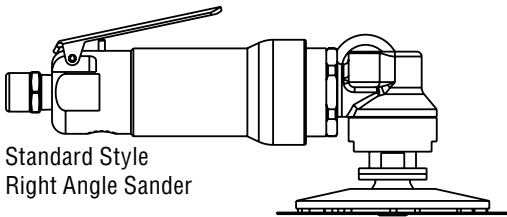

Standard Style Right Angle Sander

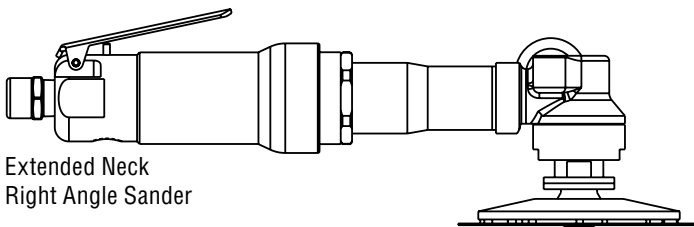

Extended Neck Right Angle Sander

Sanding Disk Mounting for Right Angle Sanders

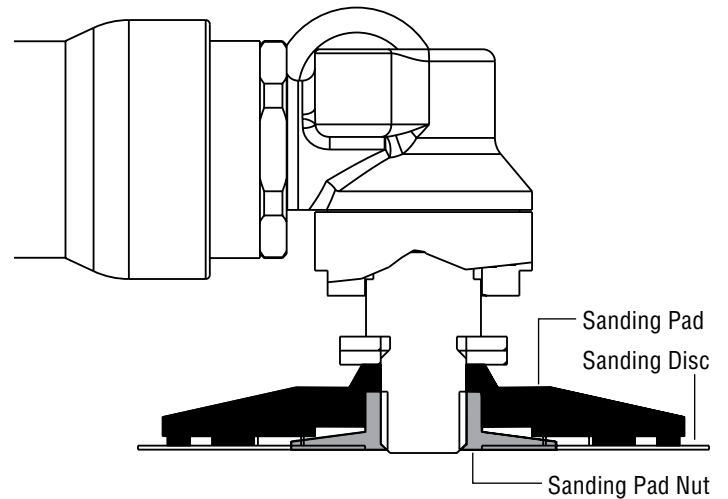
RIGHT ANGLE SANDERS

Spiralcool® Pads

Part Number	Threads	Size	Description	Maximum Speed
889271-A	3/8-24	4 Inch (100 mm)	Sanding Pad	12000 R.P.M.
849848-A	3/8-24	5 Inch (125 mm)	Sanding Pad	10000 R.P.M.
889271	5/8-11	4 Inch (100 mm)	Sanding Pad	12000 R.P.M.
849848	5/8-11	5 Inch (125 mm)	Sanding Pad	10000 R.P.M.
849913	5/8-11	7 Inch (180 mm)	Sanding Pad	8500 R.P.M.
849914	5/8-11	9 Inch (230 mm)	Sanding Pad	6500 R.P.M.
849259-A	3/8-24		Sanding Pad Nut	
849259	5/8-11		Sanding Pad Nut	
102-SPWR			Pad Nut Wrench	

Short Right Angle Sanders, Buffers & Polishers for Surface Finishing Abrasives

300RA Series & 307RA Series

300RA6K;15000
307RA2K;10000;5SP

400RA Series & 407RA Series

400RA2R;10000;5SP
400RA2K;10000;5SP

Sanding Pad Size	Exhaust Direction	Spindle Output	Lever Style	Model Number	Sanding Pad Size	Exhaust Direction	Spindle Output	Lever Style	Model Number
3 Inch (75 mm)	Rear	1/4-20	Standard Lever	300RA6;15000	4 Inch (100 mm)	Side	3/8-24	Standard Lever	400RA4;10000;4SP
			Safety Lever	300RA6K;15000				Safety Lever	400RA4K;10000;4SP
Standard Lever		307RA4;10000;4SP	Standard Lever	400RA4R;10000;4SP					
Safety Lever		307RA4K;10000;4SP	Safety Lever	400RA4KR;10000;4SP					
4 Inch (100 mm)		5/8-11	Standard Lever	300RA2;15000;45SP		Side		Standard Lever	410RA2;13000;45SP
			Safety Lever	300RA2K;15000;45SP				Safety Lever	410RA2K;13000;45SP
4 1/2 Inch (115 mm)		5/8-11	Standard Lever	307RA2;10000;5SP		Rear		Standard Lever	410RA2R;13000;45SP
			Safety Lever	307RA2K;10000;5SP				Safety Lever	410RA2KR;13000;45SP
5 Inch (125 mm)		5/8-11	Standard Lever	307RA2K;10000;5SP		Side		Standard Lever	400RA2;10000;5SP
			Safety Lever	307RA2K;10000;5SP				Safety Lever	400RA2K;10000;5SP
					Rear		Standard Lever	400RA2R;10000;5SP	
							Safety Lever	400RA2KR;10000;5SP	
					Side		Standard Lever	407RA2;8000;5SP	
							Safety Lever	407RA2K;8000;5SP	

The 307RA is available with rated speeds within the range of 7000 to 10000 RPM.

The 407RA is available with rated speeds within the range of 6000 to 8000 RPM.

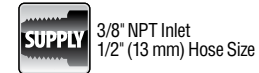
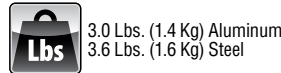
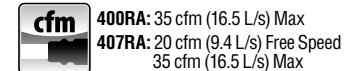
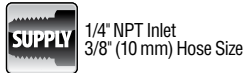
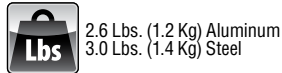
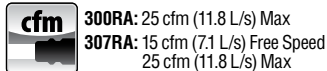
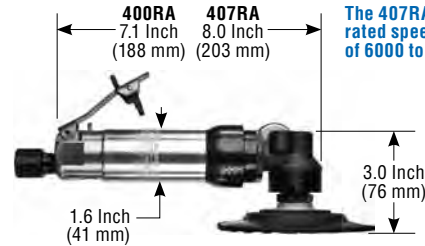
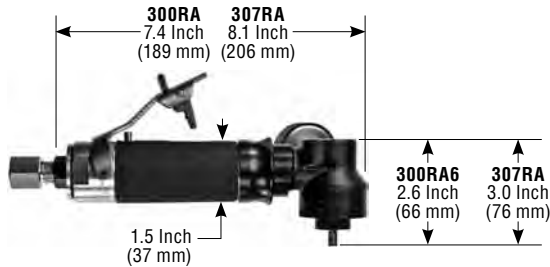

STANDARD EQUIPMENT

- Tool
- Operating Instructions and Service Manual
- Wrenches (sizes based on options)

300RA & 307RA Alternate Options

Case Material



Aluminum Case Steel Case

300-400RA & 307-407RA Alternate Options

Lever Style



Safety Lever Standard Lever

400RA & 407RA Alternate Options

Case Material



Aluminum Case Steel Case

Surface Conditioning Abrasive Mounting



Extended Right Angle Sanders, Buffers & Polishers for Surface Finishing Abrasives

300RAE Series & 307RAE Series

300RAE6K;15000
307RAE2K;10000;5SP

400RAE Series & 407RAE Series

400RAE2R;10000;5SP
400RAE2K;10000;5SP

Sanding Pad Size	Exhaust Direction	Spindle Output	Lever Style	Model Number	Sanding Pad Size	Exhaust Direction	Spindle Output	Lever Style	Model Number
3 Inch (75 mm)	Rear	1/4-20	Standard Lever	300RAE6;15000	4 Inch (100 mm)	Side	3/8-24	Standard Lever	400RAE4;10000;4SP
			Safety Lever	300RAE6K;15000				Safety Lever	400RAE4K;10000;4SP
Standard Lever		317RAE4;12000;4SP	Standard Lever	400RAE4R;10000;4SP					
Safety Lever		317RAE4K;12000;4SP	Safety Lever	400RAE4KR;10000;4SP					
4 1/2 Inch (115 mm)		5/8-11	Standard Lever	300RAE2;15000;45SP		4 1/2 Inch (115 mm)	Side	Standard Lever	410RAE2;13000;45SP
Safety Lever				300RAE2K;15000;45SP					Safety Lever
5 Inch (125 mm)		Standard Lever	Safety Lever	307RAE2;10000;5SP		5 Inch (125 mm)	Rear	Standard Lever	410RAE2R;13000;45SP
				307RAE2K;10000;5SP					Safety Lever
5 Inch (125 mm)	Side	Standard Lever	400RAE2;10000;5SP	5 Inch (125 mm)	Side	Standard Lever	400RAE2;10000;5SP		
			Safety Lever				400RAE2K;10000;5SP	Safety Lever	400RAE2K;10000;5SP
			Standard Lever				400RAE2R;10000;5SP	Standard Lever	400RAE2R;10000;5SP
			Safety Lever				400RAE2KR;10000;5SP	Safety Lever	400RAE2KR;10000;5SP
5 Inch (125 mm)	Side	Standard Lever	407RAE2;8000;5SP	5 Inch (125 mm)	Side	Standard Lever	407RAE2;8000;5SP		
			Safety Lever				407RAE2K;8000;5SP	Safety Lever	407RAE2K;8000;5SP

The 307RAE is available with rated speeds within the range of 7000 to 10000 RPM.

The 407RAE is available with rated speeds within the range of 6000 to 8000 RPM.

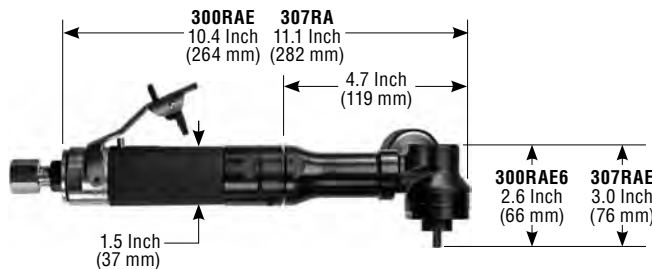

0.7 H.P. (600 W)



3.1 Lbs. (1.4 Kg) Aluminum
3.5 Lbs. (1.6 Kg) Steel



300RAE: 25 cfm (11.8 L/s) Max
307RAE: 15 cfm (7.1 L/s) Free Speed
25 cfm (11.8 L/s) Max



1/4" NPT Inlet
3/8" (10 mm) Hose Size

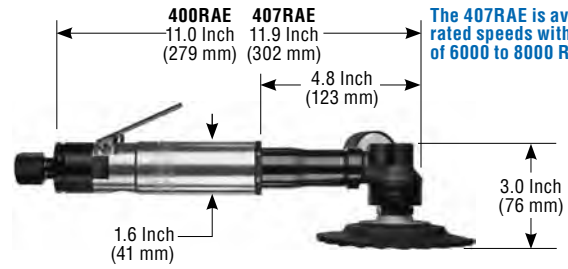

1.2 H.P. (900 W)



3.6 Lbs. (1.6 Kg) Aluminum
4.2 Lbs. (1.9 Kg) Steel



400RAE: 35 cfm (16.5 L/s) Max
407RAE: 20 cfm (9.4 L/s) Free Speed
35 cfm (16.5 L/s) Max



3/8" NPT Inlet
1/2" (13 mm) Hose Size

STANDARD EQUIPMENT

- Tool
- Operating Instructions and Service Manual
- Wrenches (sizes based on options)

300RAE & 307RAE Alternate Options

Case Material



Aluminum Case Steel Case

Lever Style



Safety Lever Standard Lever

300-400RAE & 307-407RAE Alternate Options

Case Material



Aluminum Case Steel Case

Surface Conditioning Abrasive Mounting



Short Right Angle Sanders, Buffers & Polishers for Surface Finishing Abrasives
330RA/340RA Series

330RA6K;12000

Maximum Sanding Pad Size	Max. Rated Speed	Exhaust Direction	Lever Style	MODEL NUMBER
2 Inch (50 mm) 1/4-20 Spindle Output Thread	12000 RPM	Rear	Standard Lever	330RA6;12000
			Safety Lever	330RA6K;12000
	20000 RPM		Standard Lever	340RA6;20000
			Safety Lever	340RA6K;20000

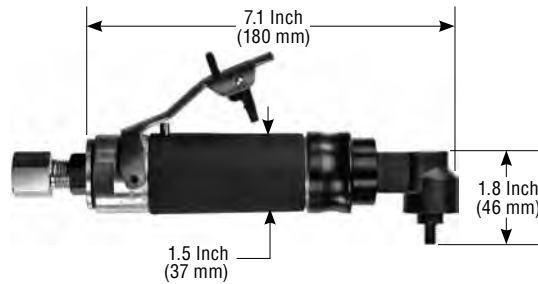
 0.7 H.P.
 (600 W)

 25 cfm
 (11.8 L/s) Max

 1.5 Lbs. (0.7 Kg) Aluminum
 1.9 Lbs. (0.9 Kg) Steel

 1/4" NPT Inlet
 3/8" (10 mm) Hose Size

STANDARD EQUIPMENT

- Tool
- Operating Instructions and Service Manual
- Wrenches (sizes based on options)

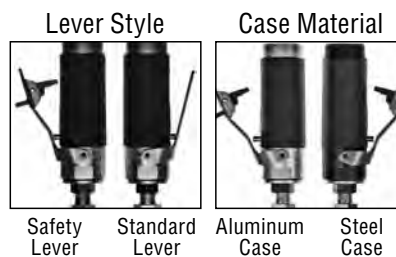
330RA/340RA Alternate Options

Surface Conditioning Abrasive Mounting

Extended Right Angle Sanders, Buffers & Polishers for Surface Finishing Abrasives

320RA Series

320RA6K;15000

420RA Series

420RA6R;13000
420RA6K;13000

Sanding Pad Size	Exhaust Direction	Lever Style	MODEL NUMBER	Sanding Pad Size	Exhaust Direction	Lever Style	MODEL NUMBER
2 Inch (50 mm) 1/4-20 Spindle Output Thread	Side	Standard Lever	320RA6;20000	2 Inch (50 mm) 1/4-20 Spindle Output Thread	Side	Standard Lever	420RA6;13000
		Safety Lever	320RA6K;20000			Safety Lever	420RA6K;13000
	Rear	Standard Lever	320RA6R;20000		Rear	Standard Lever	420RA6R;13000
		Safety Lever	320RA6KR;20000			Safety Lever	420RA6KR;13000

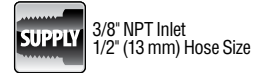
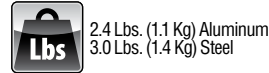
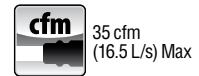
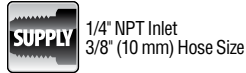
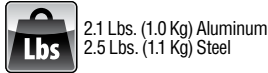
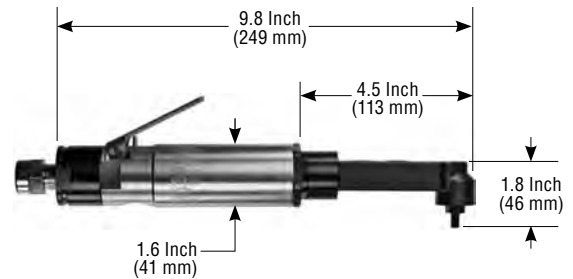
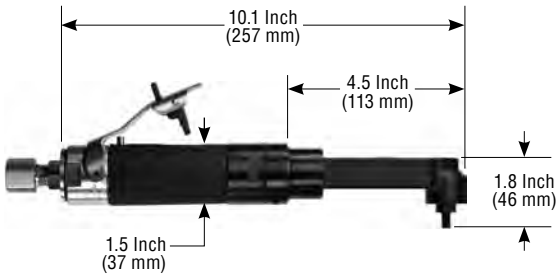

STANDARD EQUIPMENT

- Tool
- Operating Instructions and Service Manual
- Wrenches (sizes based on options)

320RA Alternate Options



320-420RA Alternate Options



420RA Alternate Options



Surface Conditioning Abrasive Mounting



Extended Right Angle Sanders, Buffers & Polishers for Surface Finishing Abrasives

3101RA Series

3101RA6K;23000

4101RA Series

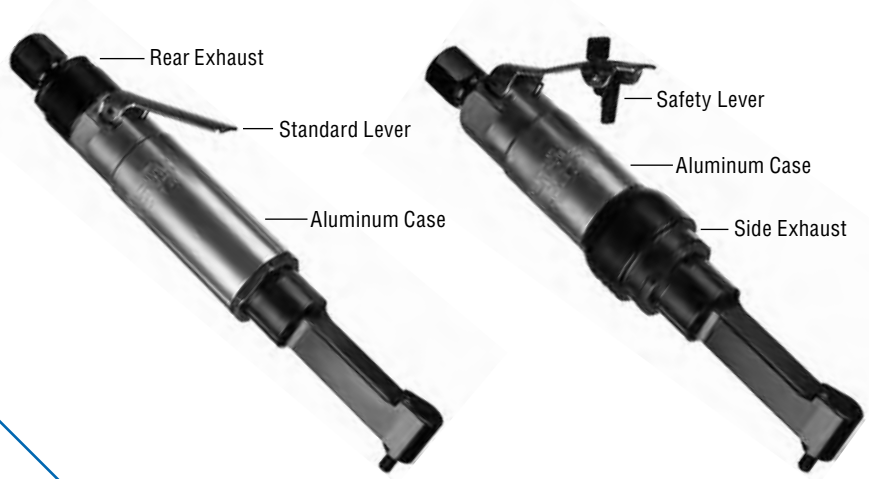
4101RA6R;15000
4101RA6K;15000

Sanding Pad Size	Exhaust Direction	Lever Style	MODEL NUMBER	Sanding Pad Size	Exhaust Direction	Lever Style	MODEL NUMBER
2 Inch (50 mm) 1/4-20 Spindle Output Thread	Side	Standard Lever	3101RA6;23000	2 Inch (50 mm) 1/4-20 Spindle Output Thread	Side	Standard Lever	4101RA6;15000
		Safety Lever	3101RA6K;23000			Safety Lever	4101RA6K;15000
	Rear	Standard Lever	3101RA6R;23000		Rear	Standard Lever	4101RA6R;15000
		Safety Lever	3101RA6KR;23000			Safety Lever	4101RA6KR;15000

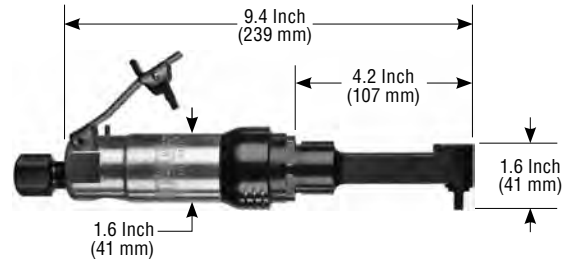
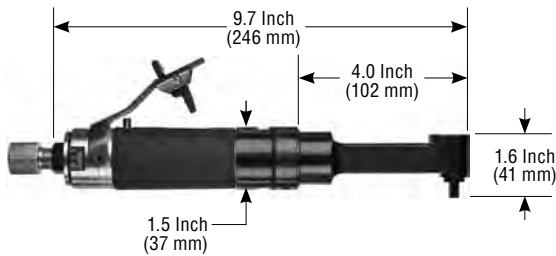
0.7 H.P.
(600 W)

25 cfm
(11.8 L/s) Max

2.0 Lbs. (0.9 Kg) Aluminum
2.4 Lbs. (1.1 Kg) Steel

1/4" NPT Inlet
3/8" (10 mm) Hose Size

1.2 H.P.
(900 W)

35 cfm
(16.5 L/s) Max

2.3 Lbs. (1.0 Kg) Aluminum
2.9 Lbs. (1.3 Kg) Steel

3/8" NPT Inlet
1/2" (13 mm) Hose Size

STANDARD EQUIPMENT

- Tool
- Operating Instructions and Service Manual
- Wrenches (sizes based on options)

3101RA Alternate Options

Case Material



Aluminum Case Steel Case

3101-4101RA Alternate Options

Lever Style



Safety Lever Standard Lever

4101RA Alternate Options

Case Material



Aluminum Case Steel Case

Surface Conditioning Abrasive Mounting



Extended Right Angle Sanders, Buffers & Polishers for Surface Finishing Abrasives

4520RA Series

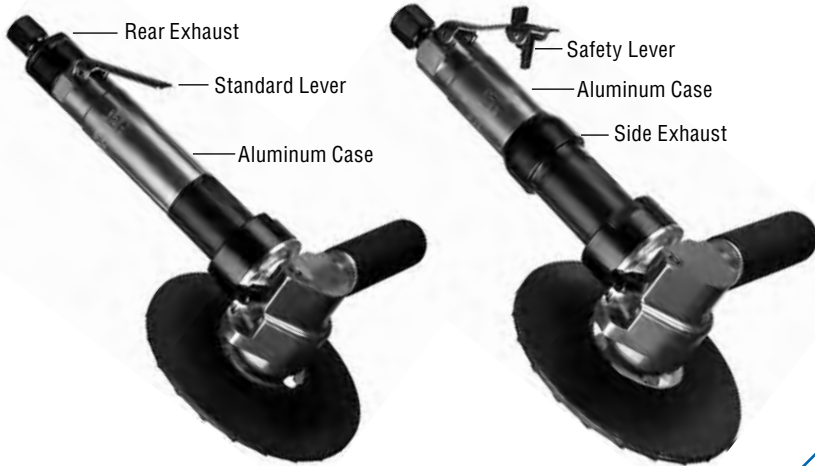
4520RAR;6000;7SP
4520RAK;6000;7SP

520RA Series

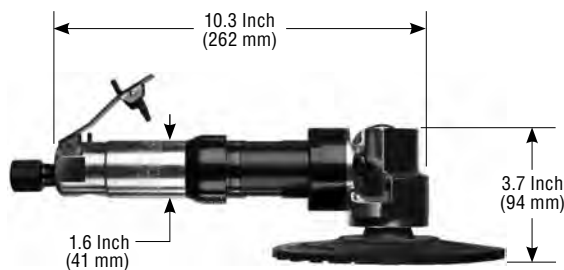

520RAK;8000;7SP

Sanding Pad Size	Exhaust Direction	Lever Style	MODEL NUMBER	Sanding Pad Size	Lever Style	MODEL NUMBER
5 Inch (125 mm) 5/8-11 Spindle Output Thread	Side	Standard Lever	4620RA;10000;5SP			
		Safety Lever	4620RAK;10000;5SP			
	Rear	Standard Lever	4620RAR;10000;5SP			
		Safety Lever	4620RAKR;10000;5SP			
7 Inch (180 mm) 5/8-11 Spindle Output Thread	Side	Standard Lever	4520RA;6000;7SP			
		Safety Lever	4520RAK;6000;7SP			
	Rear	Standard Lever	4520RAR;6000;7SP			
		Safety Lever	4520RAKR;6000;7SP			
				7 Inch (180 mm) 5/8-11 Spindle Output Thread	Standard Lever	520RA;8000;7SP
					Safety Lever	520RAK;8000;7SP

1.2 H.P.
(900 W)

35 cfm
(16.5 L/s) Max

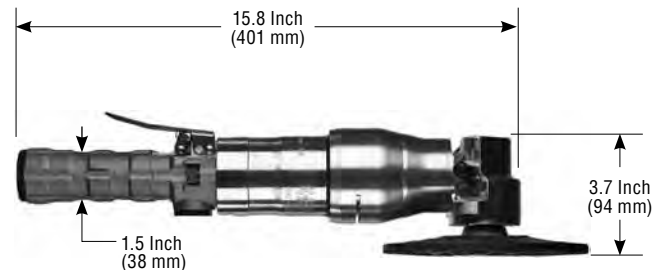
5.6 Lbs. (2.5 Kg) Aluminum
6.2 Lbs. (2.8 Kg) Steel

3/8" NPT Inlet
1/2" (13mm) Hose Size

2.0 H.P.
(1.5 kW)

20 cfm (9.4 L/s) Free Speed
40 cfm (18.9 L/s) Max

7.6 Lbs. (3.4 Kg)

3/8" NPT Inlet
1/2" (13 mm) Hose Size

STANDARD EQUIPMENT

- Tool
- Operating Instructions and Service Manual
- Wrenches (sizes based on options)

4520RA Alternate Options

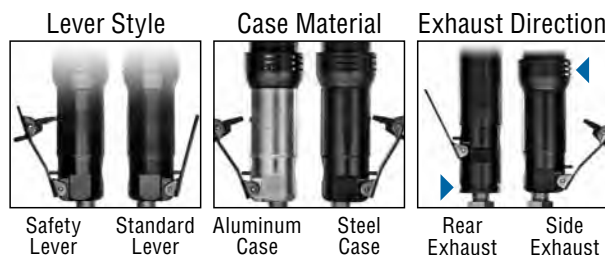

Surface Conditioning Abrasive Mounting



Geared Right Angle Sanders, Buffers & Polishers for Surface Finishing Abrasives

300RA(X)M Series



300RA3M2;4000;5SP

400RA(X)M Series



400RA3M2K;4000;7SP

4620RA(X)M Series



4620RA3M2K;4200;7SP

RIGHT ANGLE SANDERS

Sanding Pad Size	Max. Rated Speed	Lever Style	SHORT RA HEAD MODEL NUMBER	Sanding Pad Size	Exhaust Direction	Max. Rated Speed	Lever Style	MODEL NUMBER	Sanding Pad Size	Exhaust Direction	Max. Rated Speed	Lever Style	MODEL NUMBER					
5 Inch (125 mm)	5200 RPM	Standard Lever	310RA3M2;5200;5SP	7 Inch (180 mm)	Side	3800 RPM	Standard Lever	410RA3M2;3800;7SP	7 Inch (180 mm)	Side	4200 RPM	Standard Lever	4620RA3M2;4200;7SP					
		Safety Lever	310RA3M2K;5200;5SP				Safety Lever	410RA3M2K;3800;7SP				Safety Lever	4620RA3M2K;4200;7SP					
	4000 RPM	Standard Lever	300RA3M2;4000;5SP			2900 RPM	Standard Lever	400RA3M2;2900;7SP			3100 RPM	Standard Lever	4620RA5M2;3100;7SP					
		Safety Lever	300RA3M2K;4000;5SP				Safety Lever	400RA3M2K;2900;7SP				Safety Lever	4620RA5M2K;3100;7SP					
	3000 RPM	Standard Lever	300RA5M2;3000;5SP			2200 RPM	Standard Lever	400RA5M2;2200;7SP			1900 RPM	Standard Lever	4620RA8M2;1900;7SP					
		Safety Lever	300RA5M2K;3000;5SP				Safety Lever	400RA5M2K;2200;7SP				Safety Lever	4620RA8M2K;1900;7SP					
	1800 RPM	Standard Lever	300RA8M2;1800;5SP			1300 RPM	Standard Lever	400RA8M2;1300;7SP			4200 RPM	Standard Lever	4620RA3M2R;4200;7SP					
		Safety Lever	300RA8M2K;1800;5SP				Safety Lever	400RA8M2K;1300;7SP				Safety Lever	4620RA3M2RK;4200;7SP					
						5/8-11 Spindle Output Thread	Rear	3800 RPM			Standard Lever	410RA3MR;3800;7SP	5/8-11 Spindle Output Thread	Rear	3100 RPM	Standard Lever	4620RA5M2R;3100;7SP	
											2900 RPM	Safety Lever				410RA3MRK;3800;7SP	Safety Lever	4620RA5M2RK;3100;7SP
								2200 RPM				Standard Lever			400RA3M2R;2900;7SP	1900 RPM	Standard Lever	4620RA8M2R;1900;7SP
											1300 RPM	Safety Lever			400RA3M2RK;2900;7SP		Safety Lever	4620RA8M2RK;1900;7SP
				2200 RPM	Standard Lever			400RA5M2R;2200;7SP										
					1300 RPM			Safety Lever	400RA5M2RK;2200;7SP									
				1300 RPM		Standard Lever	400RA8M2R;1300;7SP											
					1300 RPM	Safety Lever	400RA8M2RK;1300;7SP											

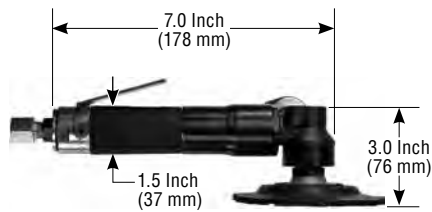

HP 0.7 H.P. (600 W) **cfm** 25 cfm (11.8 L/s) Max

Lbs 3.6 Lbs (1.6 Kg) Aluminum
4.0 Lbs (1.8 Kg) Steel **SUPPLY** 1/4" NPT Inlet
3/8" (10 mm) Hose Size

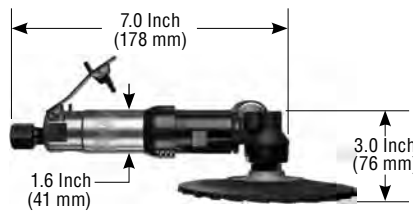

HP 1.2 H.P. (900 W) **cfm** 35 cfm (16.5 L/s) Max

Lbs 4.5 Lbs. (2.0 Kg) Aluminum
5.1 Lbs. (2.3 Kg) Steel **SUPPLY** 3/8" NPT Inlet
1/2" (13 mm) Hose Size

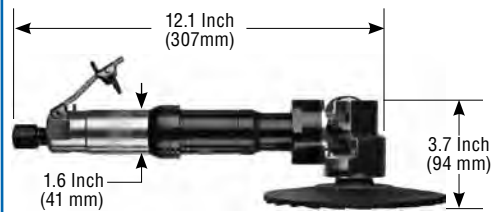

HP 1.2 H.P. (900 W) **cfm** 35 cfm (16.5 L/s) Max

Lbs 6.3 Lbs (2.9 Kg) Aluminum
6.9 Lbs (3.1 Kg) Steel **SUPPLY** 3/8" NPT Inlet
1/2" (13 mm) Hose Size

STANDARD EQUIPMENT

- Tool
- Operating Instructions and Service Manual
- Wrenches (sizes based on options)

300RA(X)M, 400RA(X)M & 4620RA(X)M Alternate Options

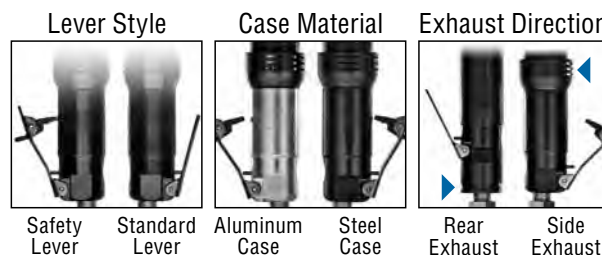

Surface Conditioning Abrasive Mounting



Extended Right Angle Sanders, Buffers & Polishers for Surface Finishing Abrasives

300RAE(X)M Series

400RAE(X)M Series

300RAE3M2K;4000;5SP

400RAE3M2R;2900;7SP

Sanding Pad Size	Max. Rated Speed	Lever Style	MODEL NUMBER	Sanding Pad Size	Exhaust Direction	Max. Rated Speed	Lever Style	MODEL NUMBER
5 Inch (125 mm) 5/8-11 Spindle Output Thread	5200 RPM	Standard Lever	310RAE3M2;5200;5SP	7 Inch (180 mm) 5/8-11 Spindle Output Thread	Side	3800 RPM	Standard Lever	410RAE3M2;3800;7SP
		Safety Lever	310RAE3M2K;5200;5SP				Safety Lever	410RAE3M2K;3800;7SP
	4000 RPM	Standard Lever	300RAE3M2;4000;5SP			2900 RPM	Standard Lever	400RAE3M2;2900;7SP
		Safety Lever	300RAE3M2K;4000;5SP			Safety Lever	400RAE3M2K;2900;7SP	
	3000 RPM	Standard Lever	300RAE5M2;3000;5SP			2200 RPM	Standard Lever	400RAE5M2;2200;7SP
		Safety Lever	300RAE5M2K;3000;5SP				Safety Lever	400RAE5M2K;2200;7SP
	1800 RPM	Standard Lever	300RAE8M2;1800;5SP			1300 RPM	Standard Lever	400RAE8M2;1300;7SP
		Safety Lever	300RAE8M2K;1800;5SP				Safety Lever	400RAE8M2K;1300;7SP
					Rear	3800 RPM	Standard Lever	410RAE3M2R;3800;7SP
							Safety Lever	410RAE3M2RK;3800;7SP
						2900 RPM	Standard Lever	400RAE3M2R;2900;7SP
							Safety Lever	400RAE3M2RK;2900;7SP
						2200 RPM	Standard Lever	400RAE5M2R;2200;7SP
							Safety Lever	400RAE5M2RK;2200;7SP
				1300 RPM		Standard Lever	400RAE8M2R;1300;7SP	
						Safety Lever	400RAE8M2RK;1300;7SP	

RIGHT ANGLE SANDERS

0.7 H.P.
(600W)

25 cfm
(11.8 L/s) Max

4.2 lbs (1.9 Kg) Aluminum
4.6 lbs (2.1 Kg) Steel

1/4" NPT Inlet
3/8" (10 mm) Hose Size

1.2 H.P.
(900 W)

35 cfm
(16.5 L/s) Max

5.0 Lbs. (2.3 Kg) Aluminum
5.6 Lbs. (2.5 Kg) Steel

3/8" NPT Inlet
1/2" (13mm) Hose Size

STANDARD EQUIPMENT

- Tool
- Operating Instructions and Service Manual
- Wrenches (sizes based on options)

300RAE(X)M & 400RAE(X)M Alternate Options

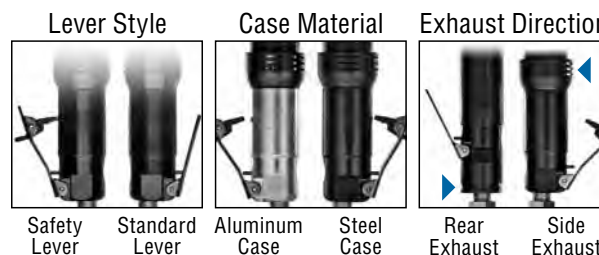

Surface Conditioning Abrasive Mounting



Horizontal Grinders

Page Number	Application	Abrasive Type/Size	Model Series	Power Output	Mounting of Abrasives
40		3 Inch (75 mm) to 4 Inch (100 mm) Type 1 Type 1 Cut-off (Type 41) Wheel	400GH 407GH4	1.2 H.P. (900 W)	
			507H4	1.5 H.P. (1.2 kW)	
41		4 Inch (100 mm), 6 Inch (150 mm) or 8 Inch (200 mm) Type 1 Type 1 Cut-off (Type 41) Wheel	520H	2.0 H.P. (1.5 kW)	
			56H	3.0 H.P. (2.3 kW)	
			65H	4.0 H.P. (3.0 kW)	
42		3/8-24 Threaded Cone Wheels	400GH1	1.2 H.P. (900 W)	
			507H1	1.5 H.P. (1.2 kW)	
43		5/8-11 Threaded Cone Wheels	400GH2 (2 Inch Max. Diameter)	1.2 H.P. (900 W)	
			507H2 (2 Inch Max. Diameter)	1.5 H.P. (1.2 kW)	
			520HCW	2.0 H.P. (1.5 kW)	
44		Collet Mounted Abrasives • Burrs • Mounted Stones	300EH	0.7 H.P. (600 W)	
			300GHD		
45		• Flap Wheels • Cartridge Rolls • Expander Wheels	400GHD	1.2 H.P. (900 W)	
			507HD	1.5 H.P. (1.2 kW)	
46		• Flap Wheels • Sanding Abrasives (5/8" or 1" ID Mount)	300GH(X)M	0.7 H.P. (600 W)	See Model Spread
			400GH(X)M	1.2 H.P. (900 W)	
			500H1M	1.5 H.P. (1.2 kW)	

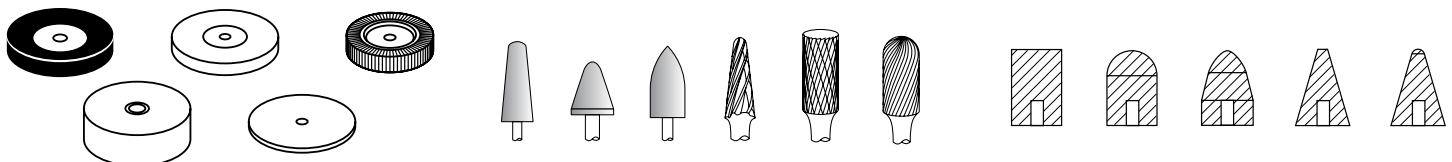

LEVER STYLE



Safety Lever Standard Lever

EXHAUST DIRECTION

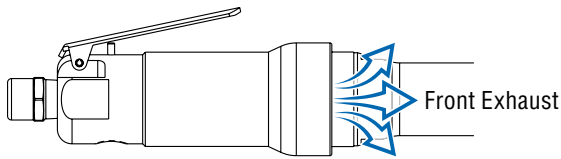

Front Exhaust

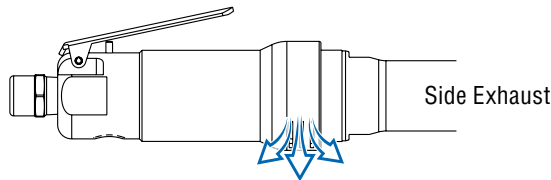

Side Exhaust

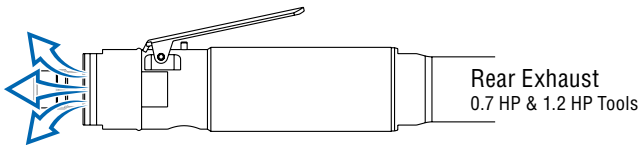

Rear Exhaust
0.7 HP & 1.2 HP Tools



Rear exhaust overhose
for the 300 Series
Only available on Rear Exhaust tools.



Rear exhaust overhose
for the 400 Series
Only available on Rear Exhaust tools.

CASE MATERIAL



Aluminum Case Material Steel Case Material

The choice of case material affects the weight and durability of the tool. By its nature, aluminum is lighter in weight than steel. Steel is more durable in aggressive environments.



THE TOP CAT® COMBINATION ARBOR

The combination arbor allows one to mount several different types to surface conditioning wheels onto our geared (low speed) horizontal sanders/polishers.

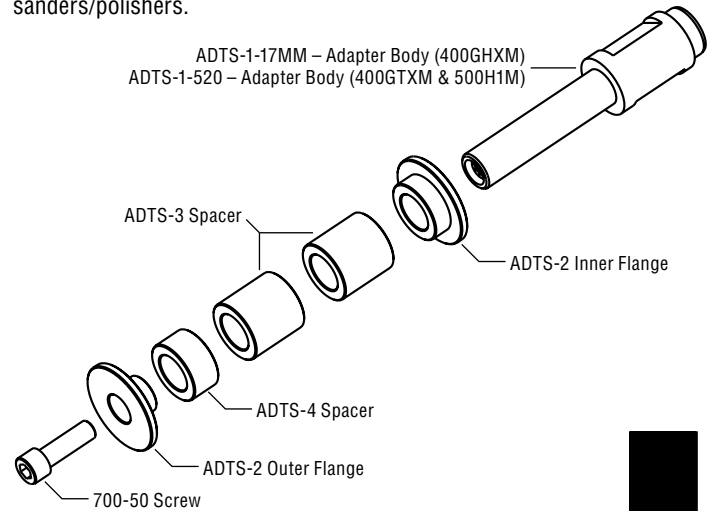

The "stack-up" or ordering of the components change based on the type and thickness of wheel you intend to use. Please examine the picture to the right and chart below for the position ordering of the components parts to properly mount your particular wheel.

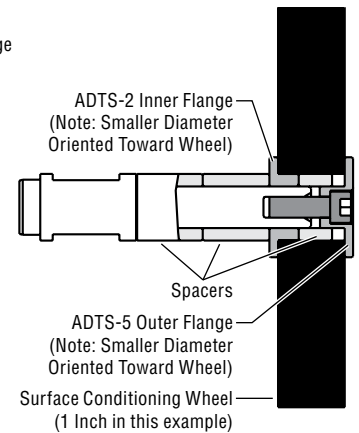

POSITION OF MOUNTING ACCESSORY: (A) (B) (C) (D) (E) (F)
(Spacer or Flange Based on Thickness of Wheel)

Wheel Type & Mounting Thickness	Position from Adapter Body					
	(A)	(B)	(C)	(D)	(E)	(F)
1" Thick Flap Wheel w/Recessed Mounting	ADTS-3 (Thick Spacer)	ADTS-3 (Thick Spacer)	ADTS-4 (Thin Spacer)	ADTS-2 (Inner Flange)		
1" Thick Surface Conditioning Wheel	ADTS-3 (Thick Spacer)	ADTS-3 (Thick Spacer)	ADTS-2 (Inner Flange)	ADTS-4 (Thin Spacer)		
2" Thick Flap Wheel w/Recessed Mounting	ADTS-3 (Thick Spacer)	ADTS-4 (Thin Spacer)	ADTS-2 (Inner Flange)	ADTS-3 (Thick Spacer)		
2" Thick Surface Conditioning Wheel	ADTS-3 (Thick Spacer)	ADTS-2 (Inner Flange)	ADTS-3 (Thick Spacer)	ADTS-4 (Thin Spacer)		
3" Thick Flap Wheel w/Recessed Mounting	ADTS-4 (Thin Spacer)	ADTS-2 (Inner Flange)	ADTS-3 (Thick Spacer)	ADTS-3 (Thick Spacer)		
3" Thick Surface Conditioning Wheel	ADTS-2 (Inner Flange)	ADTS-3 (Thick Spacer)	ADTS-3 (Thick Spacer)	ADTS-4 (Thin Spacer)		

Wheel ADTS-5 (Outer Flange)

Horizontal Grinders for 3 Inch & 4 Inch Type 1 Wheels

400GH Series & 407GH Series

507H Series



400GH4SKR;18000;301



407GH4S;15000;401

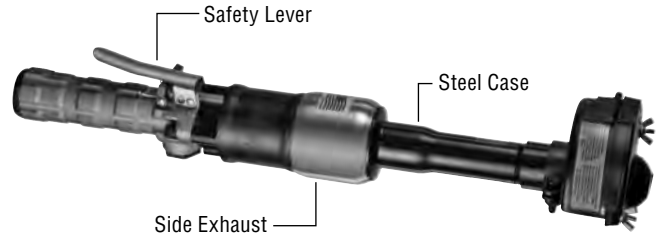

507HK4;15000;401

Guard/Wheel Size	Exhaust Direction	Lever Style	MODEL NUMBER	Guard/Wheel Size	Exhaust Direction	Lever Style	MODEL NUMBER		
3 Inch (75 mm)	Side	Standard Lever	400GH4S;18000;301	3 Inch (75 mm)	Side	Standard Lever	507HLS4;18000;301		
		Safety Lever	400GH4SK;18000;301			Safety Lever	507HKS4;18000;301		
	Rear	Standard Lever	400GH4SR;18000;301			4 Inch (100 mm)	Side	Standard Lever	507HLS4;15000;401
		Safety Lever	400GH4SKR;18000;301					Safety Lever	507HKS4;15000;401
4 Inch (100 mm)	Side	Standard Lever	407GH4S;15000;401						
		Safety Lever	407GH4SK;15000;401						

400GH

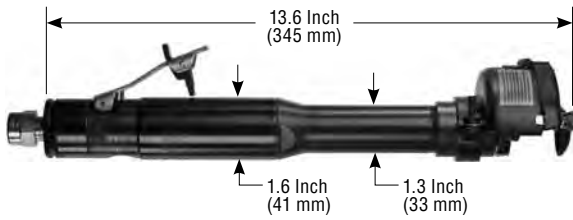

407GH

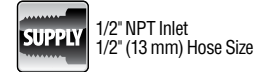
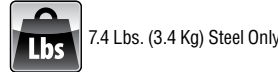
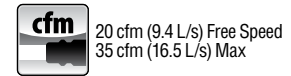
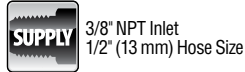
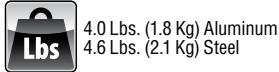
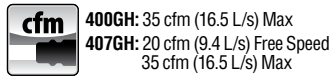
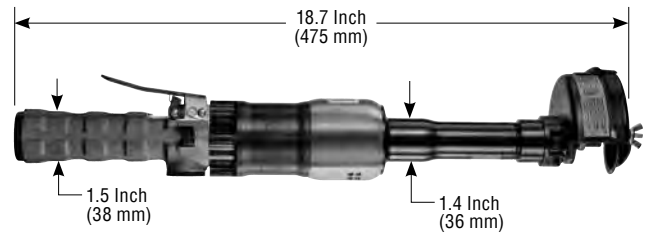
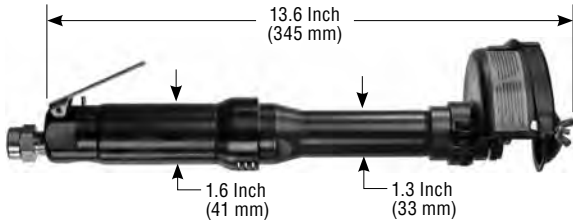

STANDARD EQUIPMENT

- Tool
- Operating Instructions and Service Manual
- Wrenches (sizes based on options)

400GH & 407GH Series Alternate Options

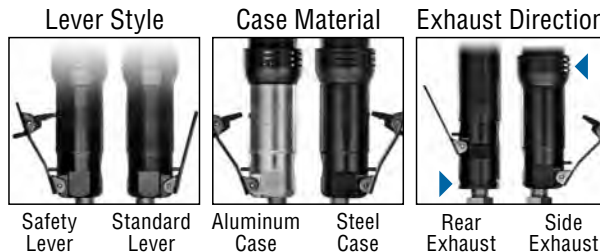

Type 1 Wheel Mounting



Horizontal Grinders for 6 Inch & 8 Inch Type 1 Wheels

520H Series



520HK;8000;601

56H Series



56HK;6000;601

65H Series



65HG;6000;801

Guard/Wheel Size	Lever Style	MODEL NUMBER	Guard/Wheel Size	Rated Speed	Lever Style	MODEL NUMBER	Guard/Wheel Size	Rated Speed	Lever Style	MODEL NUMBER				
4 Inch (100 mm)	Standard Lever	520HL;12000;401	6 Inch (150 mm)	8000 RPM	Standard Lever	56HL;8000;601	6 Inch (150 mm)	6000 RPM	Standard Lever	65HL;6000;601				
	Safety Lever	520HK;12000;401			Safety Lever	56HK;8000;601			Safety Lever	65HK;6000;601				
6 Inch (150 mm)	Standard Lever	520HL;8000;601			Standard Lever	56HL;6000;601			Standard Lever	65HL;6000;801				
	Safety Lever	520HK;8000;601			Safety Lever	56HK;6000;601			Safety Lever	65HK;6000;801				
					8 Inch (200 mm)	6000 RPM			Standard Lever	56HL;6000;801	8 Inch (200 mm)	6000 RPM	Standard Lever	65HL;6000;801
									Safety Lever	56HK;6000;801			Safety Lever	65HK;6000;801

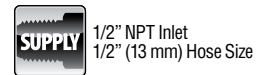
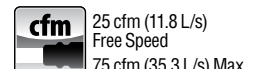
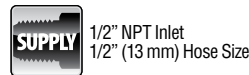
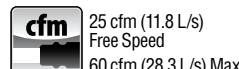
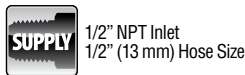
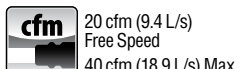
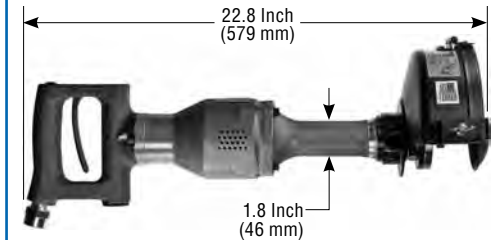
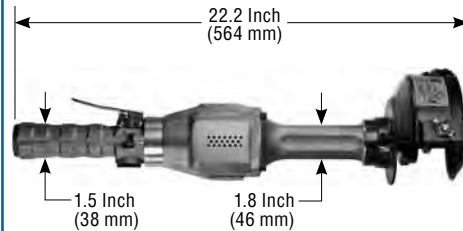
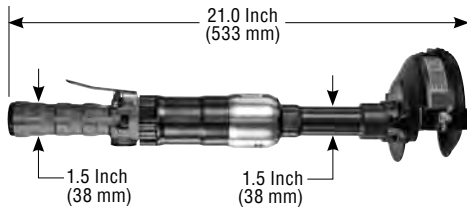

STANDARD EQUIPMENT

- Tool
- Operating Instructions and Service Manual
- Wrenches (sizes based on options)

520H, 56H & 65H Series Alternate Options

Handles



Type 1 Wheel Mounting



Horizontal Grinders for 3/8-24 Cone Wheels

400GH Series

507H Series



400GH1SK;18000



400GH1SR;18000



507HKS1;18000

Max. Rated Speed	Exhaust Direction	Lever Style	MODEL NUMBER
20000 RPM	Side	Standard Lever	400GH1S;20000
		Safety Lever	400GH1SK;20000
	Rear	Standard Lever	400GH1SR;20000
		Safety Lever	400GH1SKR;20000
18000 RPM	Side	Standard Lever	400GH1S;18000
		Safety Lever	400GH1SK;18000
	Rear	Standard Lever	400GH1SR;18000
		Safety Lever	400GH1SKR;18000

Max. Rated Speed	Exhaust Direction	Lever Style	MODEL NUMBER
18000 RPM	Side	Standard Lever	507HLS1;18000
		Safety Lever	507HKS1;18000

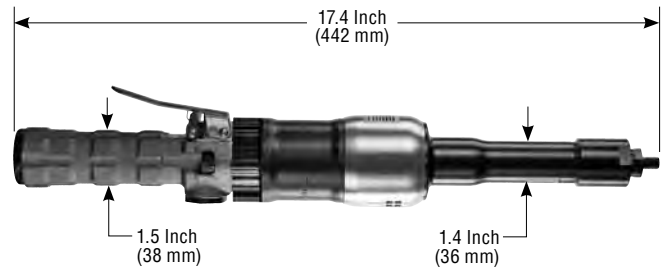
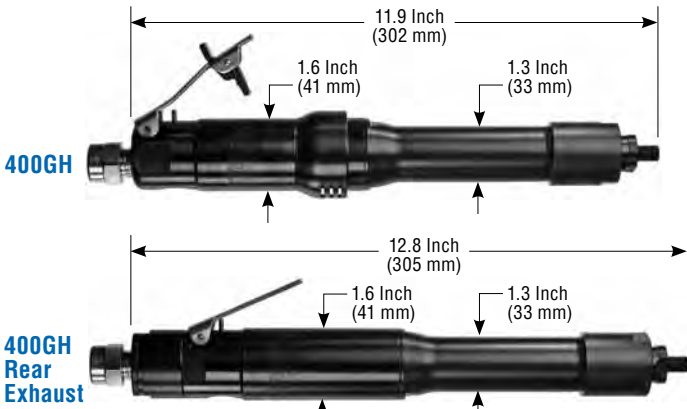

1.2 H.P. (900 W)



35 cfm (16.5 L/s)



3.2 Lbs. (1.4 Kg) Aluminum
3.8 Lbs. (1.7 Kg) Steel



3/8" NPT Inlet
1/2" (13 mm) Hose Size



1.5 H.P. (1.1 kW)



20 cfm (9.4 L/s) Free Speed
35 cfm (16.5 L/s) Max



6.5 Lbs. (3.0 Kg) Steel Only



1/2" NPT Inlet
1/2" (13 mm) Hose Size

STANDARD EQUIPMENT

- Tool
- Operating Instructions and Service Manual
- Wrenches (sizes based on options)

400GH Series Series Alternate Options

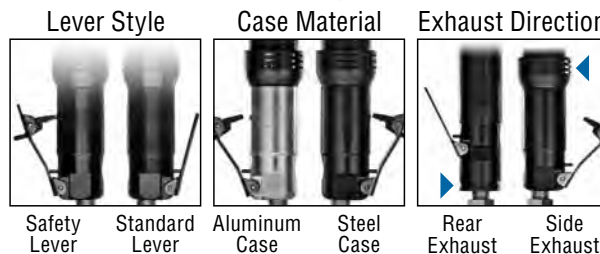

Cone Wheel Mounting



Horizontal Grinders for 5/8-11 Cone Wheels

400GH Series



507H Series

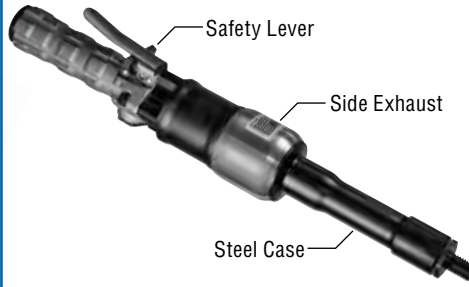

520H Series

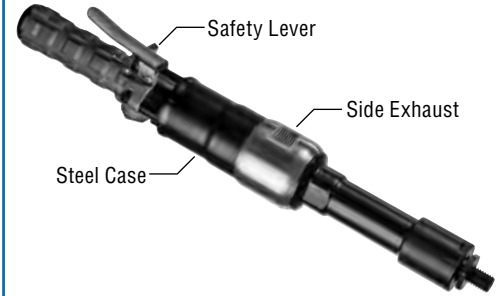

Max. Rated Speed	Exhaust Direction	Lever Style	MODEL NUMBER	Max. Rated Speed	Exhaust Direction	Lever Style	MODEL NUMBER	Max. Rated Speed	Exhaust Direction	Lever Style	MODEL NUMBER	
20000 RPM	Side	Standard Lever	400GH2S;20000	18000 RPM	Side	Standard Lever	507HLS2;18000	12000 RPM	Side	Standard Lever	520HLSCW;12000	
		Safety Lever	400GH2SK;20000			Safety Lever	507HKS2;18000			Safety Lever	520HKSCW;12000	
	Rear	Standard Lever	400GH2SR;20000			Rear	Standard Lever		400GH2SR;18000	Rear	Standard Lever	400GH2SR;18000
		Safety Lever	400GH2SRK;20000				Safety Lever		400GH2SRK;18000			

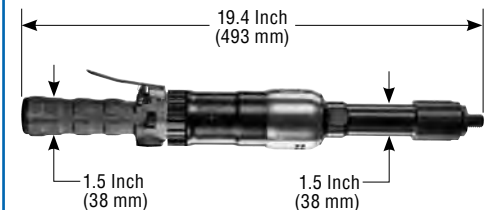
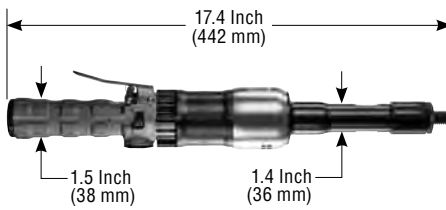
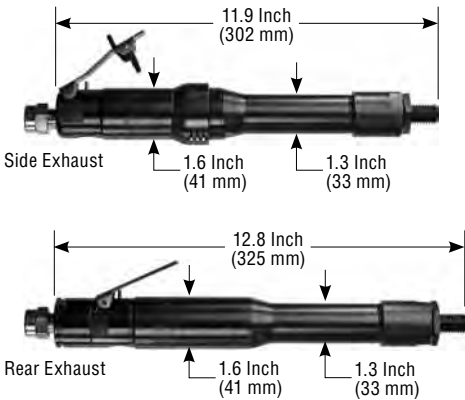

1.2 H.P. (900 W)



35 cfm (16.5 L/s)



1.5 H.P. (1.1 kW)



20 cfm (9.4 L/s) Free Speed
35 cfm (16.5 L/s) Max



2.0 H.P. (1.5 kW)



20 cfm (9.4 L/s) Free Speed
40 cfm (18.9 L/s) Max



3.2 Lbs. (1.4 Kg) Aluminum
3.8 Lbs. (1.7 Kg) Steel



3/8" NPT Inlet
1/2" (13 mm) Hose Size



6.5 Lbs. (3.0 Kg) Steel Only



1/2" NPT Inlet
1/2" (13 mm) Hose Size



8.4 Lbs. (3.8 Kg) Steel Only



1/2" NPT Inlet
1/2" (13 mm) Hose Size

STANDARD EQUIPMENT

- Tool
- Operating Instructions and Service Manual
- Wrenches (sizes based on options)

400GH Series Alternate Options

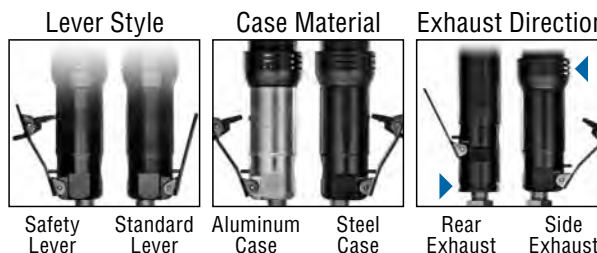

Cone Wheel Mounting



Horizontal Die Grinders (Collet Output)

300EH Series

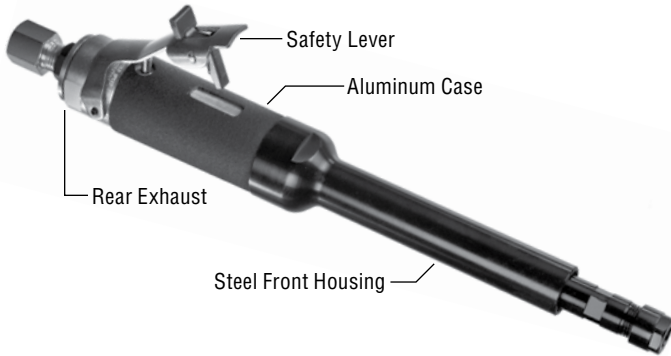

300EHK;25000;1/4

300GH Series

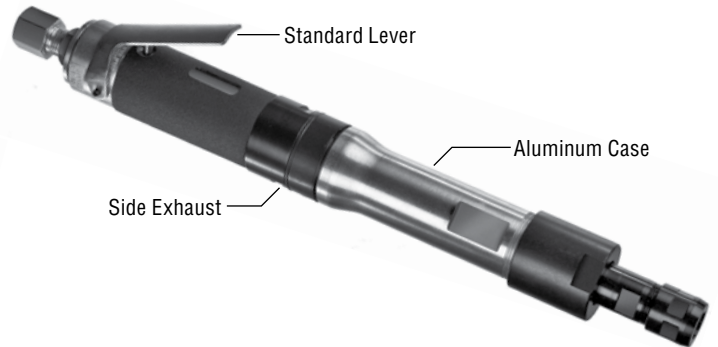

300GHD;25000;1/4

Collet Type/Capacity	Exhaust Direction	Max. Rated Speed	Lever Style	MODEL NUMBER
ER Style Insert Collet 1/4 Inch or (7 mm) Maximum	Rear	30000 RPM	Standard Lever	300EH;30000;1/4
			Safety Lever	300EHK;30000;1/4
		25000 RPM	Standard Lever	300EH;25000;1/4
			Safety Lever	300EHK;25000;1/4

Collet Type/Capacity	Exhaust Direction	Max. Rated Speed	Lever Style	MODEL NUMBER
1/4 Inch Standard ER Style Insert Collet 3/8 Inch or (10 mm) Maximum	Side	30000 RPM	Standard Lever	300GHD;30000;1/4
			Safety Lever	300GHDK;30000;1/4
			Standard Lever	300GHDR;30000;1/4
			Safety Lever	300GHDRK;30000;1/4
	Rear	25000 RPM	Standard Lever	300GHD;25000;1/4
			Safety Lever	300GHDK;25000;1/4
			Standard Lever	300GHDR;25000;1/4
			Safety Lever	300GHDRK;25000;1/4

HORIZONTAL GRINDERS

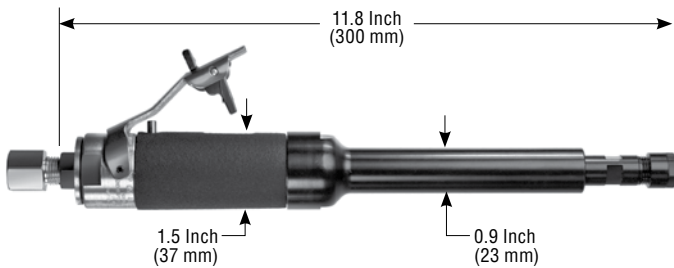

HP 0.7 H.P. (600 W)

cfm 25 cfm (11.8 L/s) Max

Lbs 2.0 Lbs. (0.9 Kg) Aluminum
2.4 Lbs. (1.1 Kg) Steel

SUPPLY 1/4" NPT Inlet
3/8" (10 mm) Hose Size

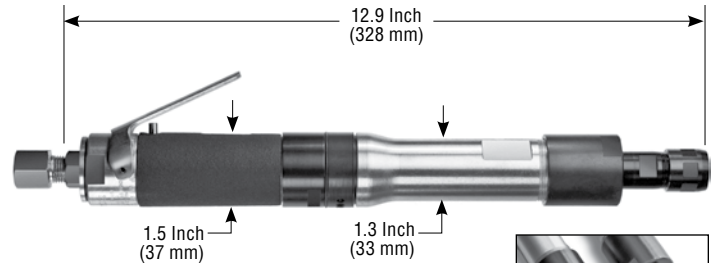

HP 0.7 H.P. (600 W)

cfm 25 cfm (11.8 L/s) Max

Lbs 2.4 Lbs. (1.1 Kg) Aluminum
2.8 Lbs. (1.3 Kg) Steel

SUPPLY 1/4" NPT Inlet
3/8" (10 mm) Hose Size



Insert Style or 2 Pc. Collets are available.

STANDARD EQUIPMENT

- Tool
- Operating Instructions and Service Manual
- Wrenches (sizes based on options)

300EH & 300GH Series Alternate Options

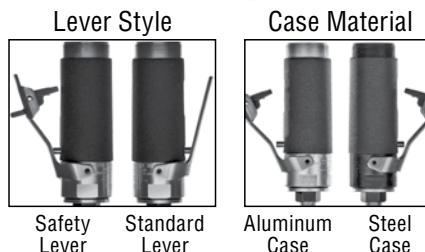

Inserted Tool Mounting



Horizontal Die Grinders (Collet Output)

400GH Series



400GHKSD;20000;1/4

507H Series

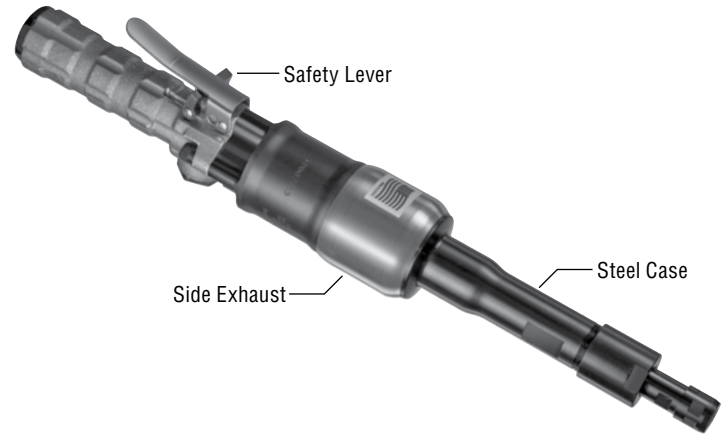

500HKSD;18000;1/4

Collet Type/Capacity	Exhaust Direction	Max. Rated Speed	Lever Style	MODEL NUMBER	Collet Type/Capacity	Exhaust Direction	Max. Rated Speed	Lever Style	MODEL NUMBER	
1/4 Inch Standard ER Style Insert Collet 3/8 Inch or (10mm) Maximum	Side	20000 RPM	Standard Lever	400GHSD;20000;1/4	1/4 Inch Standard 3/8 Inch or (10 mm) Maximum	Side	18000 RPM	Standard Lever	507HLS;18000;1/4	
			Safety Lever	400GHKSD;20000;1/4					Safety Lever	507HKSD;18000;1/4CXZ
			Rear	Standard Lever				400GHSRD;20000;1/4	Standard Lever	
				Safety Lever				400GHKSRD;20000;1/4		
	Side	18000 RPM	Standard Lever	400GHSD;18000;1/4						
			Safety Lever	400GHKSD;18000;1/4						
			Rear	Standard Lever				400GHSRD;18000;1/4		
				Safety Lever				400GHKSRD;18000;1/4		

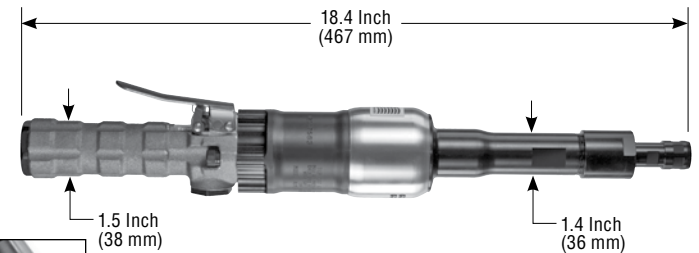
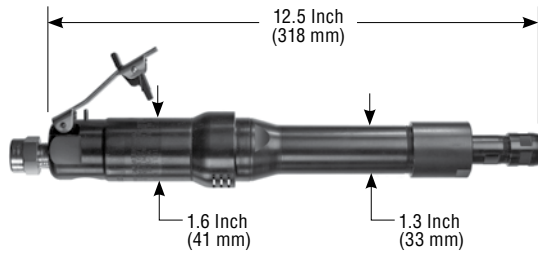

1.2 H.P.
(900 W)



35 cfm (16.5 L/s)



3.2 Lbs. (1.4 Kg) Aluminum
3.8 Lbs. (1.7 Kg) Steel



3/8" NPT Inlet
1/2" (13 mm) Hose Size



1.5 H.P.
(1.1 kW)



35 cfm
(16.5 L/s) Max



6.5 Lbs. (3.0 Kg) Steel Only



1/2" NPT Inlet
1/2" (13 mm) Hose Size

STANDARD EQUIPMENT

- Tool
- Operating Instructions and Service Manual
- Wrenches (sizes based on options)

400GH Series Alternate Options

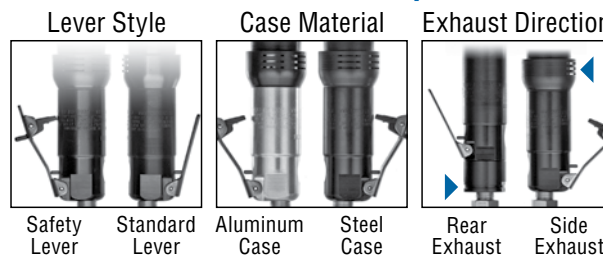

Inserted Tool Mounting



Geared Horizontal Polishers/Sanders

300GH(X)M & 400GH(X)M Series

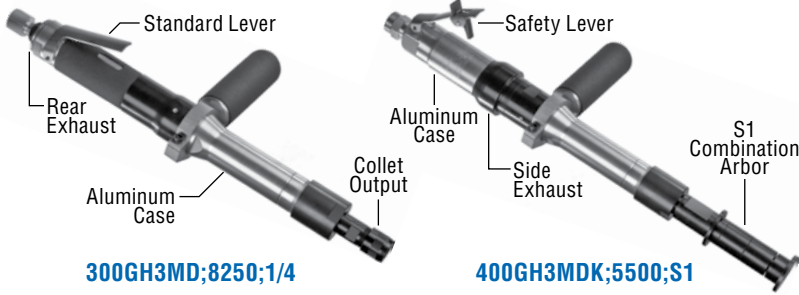

300GH3MD;8250;1/4

400GH3MDK;5500;S1

500H1M Series



500H1MK;4000;T5/8

		300GH(X)M Series		400GH(X)M Series					
Output	Gear Ratio/ Max. Rated Speed	Lever Style	MODEL NUMBER	MODEL NUMBER	Output	Gear Ratio/ Max. Rated Speed	Lever Style	MODEL NUMBER	
1/4 Inch Standard ER Style Insert Collet 3/8 Inch (8 mm) Maximum	3:1 (300GH3M 8250 RPM) (400GH3M 5500 RPM)	Standard Lever	300GH3MD;8250;1/4	400GH3MD;5500;1/4					
		Safety Lever	300GH3MDK;8250;1/4	400GH3MDK;5500;1/4					
	5:1 (300GH5M 6000 RPM) (400GH5M 4000 RPM)	Standard Lever	300GH5MD;6000;1/4	400GH5MD;4000;1/4					
		Safety Lever	300GH5MDK;6000;1/4	400GH5MDK;4000;1/4					
	8:1 (300GH8M 3750 RPM) (400GH8M 2500 RPM)	Standard Lever	300GH8MD;3750;1/4	400GH8MD;2500;1/4					
		Safety Lever	300GH8MDK;3750;1/4	400GH8MDK;2500;1/4					
S1 Combination Arbor 1"-4" Wide Surface Conditioning Abrasives	3:1 (300GH3M 8250 RPM) (400GH3M 5500 RPM)	Standard Lever	300GH3M;8250;S1	400GH3M;5500;S1	S1 Combination Arbor 1"-4" Wide Surface Conditioning Abrasives	4:1 (4000 RPM)	Standard Lever	500H1ML;4000;S1	500H1MK;4000;S1
		Safety Lever	300GH3MK;8250;S1	400GH3MK;5500;S1			Safety Lever	500H1MK;4000;S1	
	5:1 (300GH5M 6000 RPM) (400GH5M 4000 RPM)	Standard Lever	300GH5M;6000;S1	400GH5M;4000;S1					
		Safety Lever	300GH5MK;6000;S1	400GH5MK;4000;S1					
	8:1 (300GH8M 3750 RPM) (400GH8M 2500 RPM)	Standard Lever	300GH8M;3750;S1	400GH8M;2500;S1					
		Safety Lever	300GH8MK;3750;S1	400GH8MK;2500;S1					
T5/8 Mounting Wheels with a 5/8-11 Thread	3:1 (300GH3M 8250 RPM) (400GH3M 5500 RPM)	Standard Lever	300GH3M;8250;T5/8	400GH3M;5500;T5/8	T5/8 Mounting Wheels with a 5/8-11 Thread	4:1 (4000 RPM)	Standard Lever	500H1ML;4000;T5/8	500H1MK;4000;T5/8
		Safety Lever	300GH3MK;8250;T5/8	400GH3MK;5500;T5/8			Safety Lever	500H1MK;4000;T5/8	
	5:1 (300GH5M 6000 RPM) (400GH5M 4000 RPM)	Standard Lever	300GH5M;6000;T5/8	400GH5M;4000;T5/8					
		Safety Lever	300GH5MK;6000;T5/8	400GH5MK;4000;T5/8					
	8:1 (300GH8M 3750 RPM) (400GH8M 2500 RPM)	Standard Lever	300GH8M;3750;T5/8	400GH8M;2500;T5/8					
		Safety Lever	300GH8MK;3750;T5/8	400GH8MK;2500;T5/8					

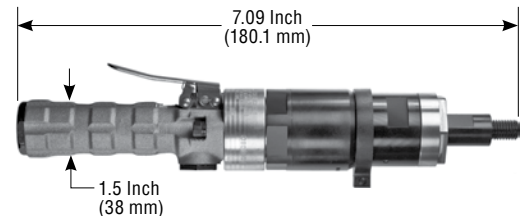
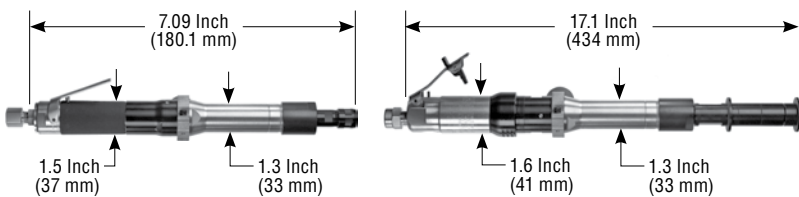

HP 0.7 H.P. (600 kW)
cfm 25 cfm (11.8 L/s) Max
Lbs 3.4 Lbs. (1.5 Kg) Aluminum
3.8 Lbs. (1.7 Kg) Steel
SUPPLY 1/4" NPT Inlet
3/8" (10 mm) Hose Size

HP 1.2 H.P. (900 W)
cfm 35 cfm (16.5 L/s)
Lbs 4.7 Lbs. (2.1 Kg) Aluminum
5.4 Lbs. (2.4 Kg) Steel
SUPPLY 1/2" NPT Inlet
1/2" (13 mm) Hose Size

HP 1.5 H.P. (1.1 kW)
cfm 35 cfm (16.5 L/s) Max
Lbs 6.7 Lbs. (3.0 Kg)
SUPPLY 1/2" NPT Inlet
1/2" (13 mm) Hose Size

STANDARD EQUIPMENT

- Tool
- Operating Instructions and Service Manual
- Wrenches (sizes based on options)

300GH(X)M, 400GH(X)M Series Alternate Options

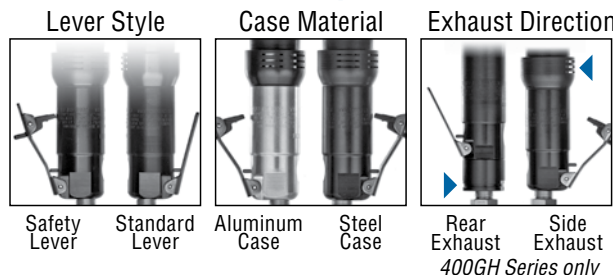

Mounting





HORIZONTAL GRINDERS

Extended Grinders

Page Number	Tool Configuration	Abrasive Size	Model Series	Power Output
50	Small Diameter Neck for Narrow Applications	<ul style="list-style-type: none"> Cone Wheels (3/8-24) – 2 Inch Max. Mounted Stones or Burrs 	400EH	1.2 H.P. (900 W)
51	Rugged Extension and Front End Design	<ul style="list-style-type: none"> Cone Wheels (3/8-24) – 2 Inch Max. Cone Wheels (5/8-11) – 2 Inch Max. Mounted Stones or Burrs 4 Inch Type 1 Wheels 	400GEH 407GEH	
52	Heavy Duty Front End Design for Larger Cone or Type 1 Wheels	<ul style="list-style-type: none"> Cone Wheels (5/8-11) 6 Inch Type 1 Wheels 	520HGEH	2.0 H.P. (1.5 kW)
53			65HGEH	4.0 H.P. (3.0 kW)
54	Extreme Duty Extension Grinder	<ul style="list-style-type: none"> Cone Wheels (5/8-11) 	65NEH	4.0 H.P. (3.0 kW)

LEVER STYLES FOR 400EH AND 400GEH SERIES TOOLS



MOUNTING OF WHEELS

Proper Mounting of Smaller Type 1 Wheels

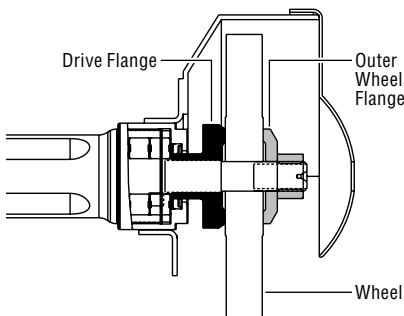

Proper Mounting of Cone Wheels

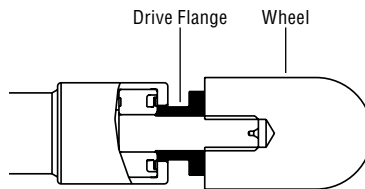

Proper Mounting of Inserted Tooling (Burrs/Mounted Stones)

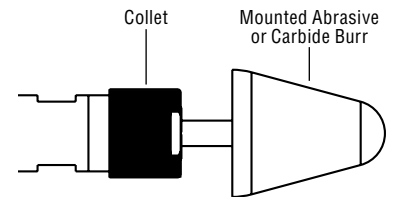

EXHAUST DIRECTION

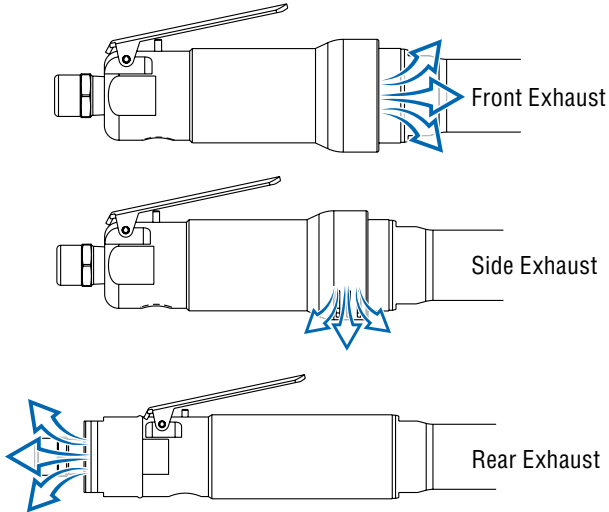

Rear exhaust overhose for the 400 Series
Only available on Rear Exhaust tools.

CASE MATERIAL FOR 400EH AND 400GEH SERIES TOOLS



The choice of case material affects the weight and durability of the tool. By it's nature, aluminum is lighter in weight than steel. Steel is more durable in aggressive environments.

EXTENSION LENGTH

The "+XX" dimension that is designated in the model number is considered the "Operational Extension Length". This dimension is the actual length of the extended housing from the front of the motor forward. The operator should use this dimension as a means to judge the length of necessary extension based on the application. This should not be confused with the "Overall Length" which includes the actual length of the motor and handle.

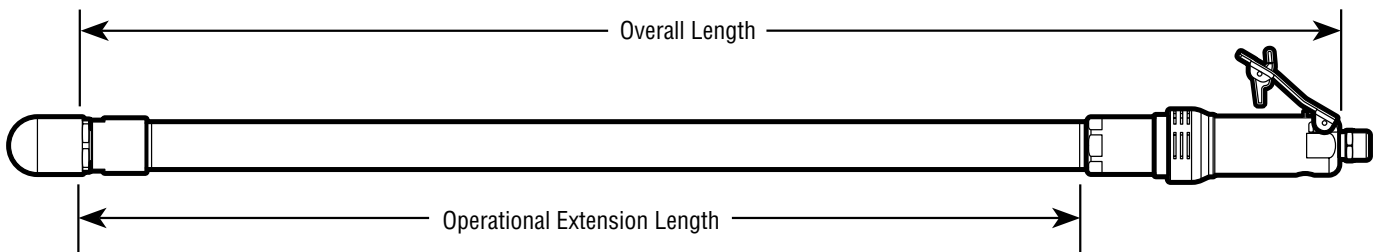

Narrow Neck Extended Grinders

400EH Series



Output	Max. Rated Speed	Lever Style	MODEL NUMBER			
			with 7 Inch Extension	with 13 Inch Extension	with 26 Inch Extension	with 36 Inch Extension
Collet ER Style Insert Collet 3/8 Inch (8mm) Maximum	20,000 RPM	Standard Lever	400EHS+7;20000;1/4	400EHS+13;20000;1/4	400EHS+26;20000;1/4	400EHS+36;20000;1/4
		Safety Lever	400EHSK+7;20000;1/4	400EHSK+13;20000;1/4	400EHSK+26;20000;1/4	400EHSK+36;20000;1/4
	18,000 RPM	Standard Lever	400EHS+7;18000;1/4	400EHS+13;18000;1/4	400EHS+26;18000;1/4	400EHS+36;18000;1/4
		Safety Lever	400EHSK+7;18000;1/4	400EHSK+13;18000;1/4	400EHSK+26;18000;1/4	400EHSK+36;18000;1/4
Cone Wheel 3/8-24 Cone Wheel Spindle	20,000 RPM	Standard Lever	400EHS1+7;20000	400EHS1+13;20000	400EHS1+26;20000	400EHS1+36;20000
		Safety Lever	400EHSK1+7;20000	400EHSK1+13;20000	400EHSK1+26;20000	400EHSK1+36;20000
	18,000 RPM	Standard Lever	400EHS1+7;18000	400EHS1+13;18000	400EHS1+26;18000	400EHS1+36;18000
		Safety Lever	400EHSK1+7;18000	400EHSK1+13;18000	400EHSK1+26;18000	400EHSK1+36;18000

Other Collet Sizes are Available

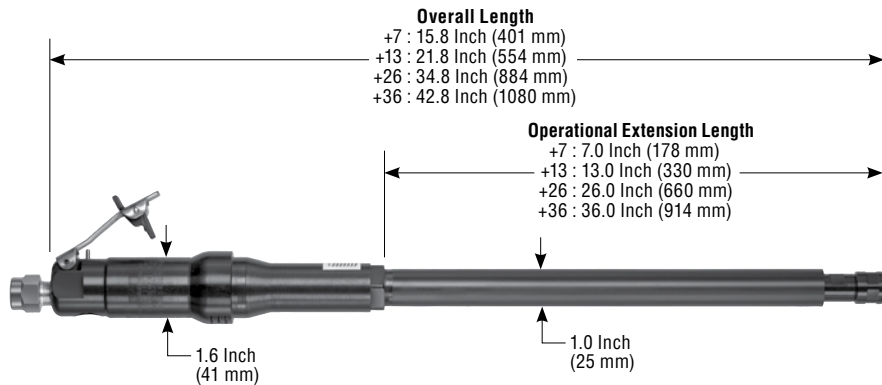

HP 1.2 H.P. (900 W)

Lbs +7: 4.8 Lbs. (2.2 Kg)
+13: 6.0 Lbs. (2.7 Kg)
+26: 8.7 Lbs. (3.9 Kg)
+36: 10.7 Lbs. (4.8 Kg)

cfm 35 cfm (16.5 L/s) Max

SUPPLY 3/8" NPT Inlet
1/2" (13mm) Hose Size

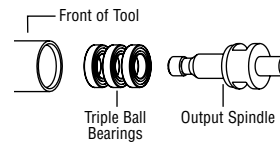

STANDARD EQUIPMENT

- Tool
- Operating Instructions and Service Manual
- Wrenches (sizes based on options)

400EH Series Alternate Options

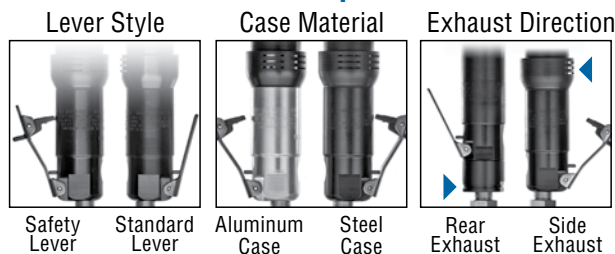

Abrasive Disk Mounting



Extended Grinders

400GEH & 407GEH Series



Output	Max. Rated Speed	Lever Style	MODEL NUMBER		
			with 15 Inch Extension	with 28 Inch Extension	with 38 Inch Extension
Collet ER Style Insert Collet 3/8 Inch (8mm) Maximum	20,000 RPM	Standard Lever	400GEHSD+15;20000;1/4	400GEHSD+28;20000;1/4	400GEHSD+38;20000;1/4
		Safety Lever	400GEHSDK+15;20000;1/4	400GEHSDK+28;20000;1/4	400GEHSDK+38;20000;1/4
	18,000 RPM	Standard Lever	400GEHSD+15;18000;1/4	400GEHSD+28;18000;1/4	400GEHSD+38;18000;1/4
		Safety Lever	400GEHSDK+15;18000;1/4	400GEHSDK+28;18000;1/4	400GEHSDK+38;18000;1/4
Cone Wheel 3/8-24 Cone Wheel Spindle	20,000 RPM	Standard Lever	400GEHS1+15;20000	400GEHS1+28;20000	400GEHS1+38;20000
		Safety Lever	400GEHSK1+15;20000	400GEHSK1+28;20000	400GEHSK1+38;20000
	18,000 RPM	Standard Lever	400GEHS1+15;18000	400GEHS1+28;18000	400GEHS1+38;18000
		Safety Lever	400GEHSK1+15;18000	400GEHSK1+28;18000	400GEHSK1+38;18000
Cone Wheel 5/8-11 Cone Wheel Spindle	20,000 RPM	Standard Lever	400GEHS2+15;20000	400GEHS2+28;20000	400GEHS2+38;20000
		Safety Lever	400GEHSK2+15;20000	400GEHSK2+28;20000	400GEHSK2+38;20000
	18,000 RPM	Standard Lever	400GEHS2+15;18000	400GEHS2+28;18000	400GEHS2+38;18000
		Safety Lever	400GEHSK2+15;18000	400GEHSK2+28;18000	400GEHSK2+38;18000
4" Type 1 Wheel 3/8-24 Type 1 Wheel	15,000 RPM	Standard Lever	407GEHS4+15;15000;401	407GEHS4+28;15000;401	407GEHS4+38;15000;401
		Safety Lever	407GEHSK4+15;15000;401	407GEHSK4+28;15000;401	407GEHSK4+38;15000;401

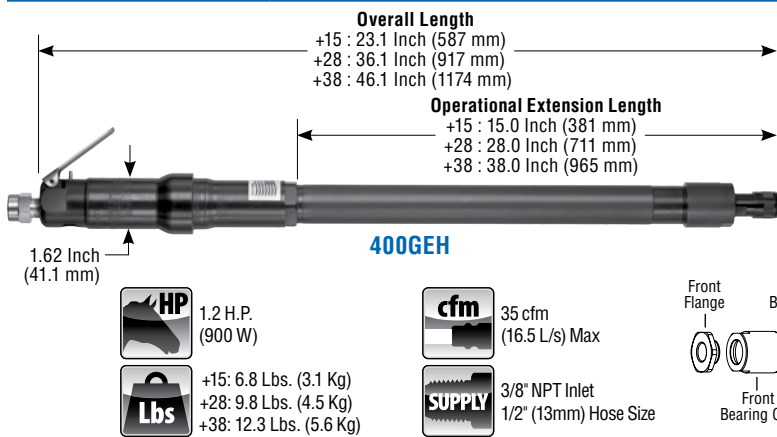

Other Collet Sizes are Available

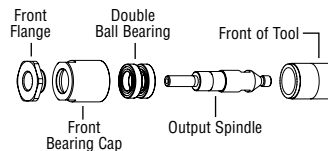

EXTENDED GRINDERS

STANDARD EQUIPMENT

- Tool
- Operating Instructions and Service Manual
- Wrenches (sizes based on options)

400GEH & 407GEH Series Alternate Options

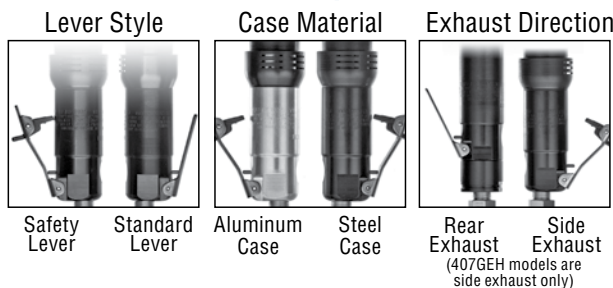

Abrasive Disk Mounting



Extended Grinders

520HGEH Series



+38 Length Shown - Other Lengths Available

520HGEHKCW+38;12000

520HGEHK+38;8000;601

Additionally Extended Versions
(We can assemble extensions
together for longer versions -
contact us for details)

Output	Max. Rated Speed	Lever Style	MODEL NUMBER		
			with 15 Inch Extension	with 28 Inch Extension	with 38 Inch Extension
Cone Wheel 5/8-11 Cone Wheel Spindle	12,000 RPM	Standard Lever	520HGEHLCW+15;12000	520HGEHLCW+28;12000	520HGEHLCW+38;12000
		Safety Lever	520HGEHKCW+15;12000	520HGEHKCW+28;12000	520HGEHKCW+38;12000
		Spade Handle	520HGEHGCW+15;12000	520HGEHGCW+28;12000	520HGEHGCW+38;12000
6" Type 1 Wheel 5/8-11 Type 1 Wheel Spindle	8,000 RPM	Standard Lever	520HGEHL+15;8000;601	520HGEHL+28;8000;601	520HGEHL+38;8000;601
		Safety Lever	520HGEHK+15;8000;601	520HGEHK+28;8000;601	520HGEHK+38;8000;601
		Spade Handle	520HGEHG+15;8000;601	520HGEHG+28;8000;601	520HGEHG+38;8000;601

Overall Length

+15 : 30.2 Inch (767 mm)
+28 : 43.2 Inch (1097 mm)
+38 : 53.2 Inch (1351 mm)

Operational Extension Length

+15 : 15.0 Inch (381 mm)
+28 : 28.0 Inch (711 mm)
+38 : 38.0 Inch (965 mm)

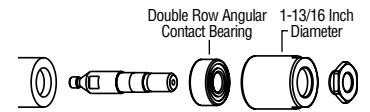

Heavy Duty Front End Design to Accommodate All Cone Wheels

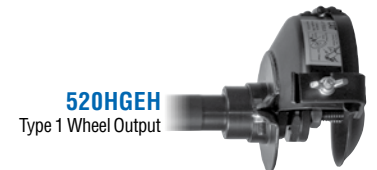
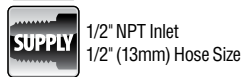
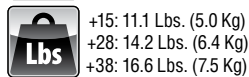
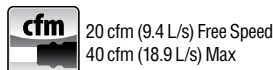

STANDARD EQUIPMENT

- Tool
- Operating Instructions and Service Manual
- Wrenches (sizes based on options)

520HGEH Series Alternate Options



Abrasive Disk Mounting



Extended Grinders

65HGEH Series



+38 Length Shown - Other Lengths Available

Additionally Extended Versions
(We can assemble extensions
together for longer versions -
contact us for details)

Output	Lever Style	MODEL NUMBER		
		with 15 Inch Extension	with 28 Inch Extension	with 38 Inch Extension
Cone Wheel 5/8-11 Cone Wheel Spindle	Standard Lever	65HGEHLCW+15;8000	65HGEHLCW+28;8000	65HGEHLCW+38;8000
	Safety Lever	65HGEHKCW+15;8000	65HGEHKCW+28;8000	65HGEHKCW+38;8000
	Spade Handle	65HGEHGCW+15;8000	65HGEHGCW+28;8000	65HGEHGCW+38;8000
6" Type 1 Wheel 5/8-11 Type 1 Wheel Spindle	Standard Lever	65HGEHL+15;8000;601	65HGEHL+28;8000;601	65HGEHL+38;8000;601
	Safety Lever	65HGEHK+15;8000;601	65HGEHK+28;8000;601	65HGEHK+38;8000;601
	Spade Handle	65HGEHG+15;8000;601	65HGEHG+28;8000;601	65HGEHG+38;8000;601

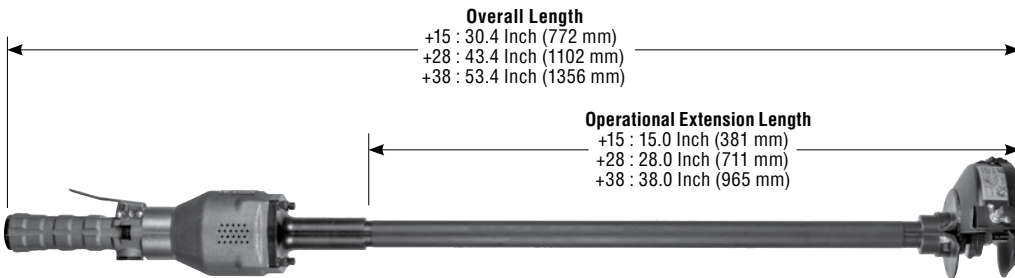

HP 4.0 H.P.
(3000 W)

Lbs +15: 14.1 Lbs. (6.4 Kg)
+28: 17.2 Lbs. (7.8 Kg)
+38: 19.6 Lbs. (8.9 Kg)

cfm 25 cfm (11.8 L/s) Free Speed
75 cfm (35.2 L/s) Max

SUPPLY 1/2" NPT Inlet
1/2" (13mm) Hose Size

65HGEHCW
5/8-11 Cone Wheel Output

65HGEH
Type 1 Wheel Output

STANDARD EQUIPMENT

- Tool
- Operating Instructions and Service Manual
- Wrenches (sizes based on options)

65HGEH Series Alternate Options



Abrasive Disk Mounting



Extended Grinders

65NEH Series

Extreme Duty Extended Grinder



65NEHCW+28;8000

+28 Length Shown - Other Lengths Available

Output	Lever Style	with 28 Inch Extension	with 38 Inch Extension
		Cone Wheel 5/8-11 Cone Wheel Spindle	Standard Lever
	Safety Lever	65NEHCW+28;8000	65NEHCW+38;8000
	Spade Handle	65NEHGCW+28;8000	65NEHGCW+38;8000

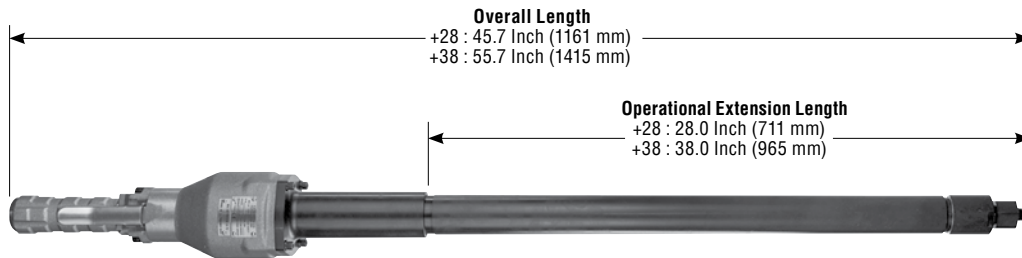

4.0 H.P.
(3000 W)



25 cfm (11.8 L/s) Free Speed
75 cfm (35.2 L/s) Max

65NEHCW
5/8-11 Cone Wheel Output



+28: 24.3 Lbs (11.0 Kg)
+38: 28.1 Lbs (12.7 Kg)



1/2" NPT Inlet
1/2" (13mm) Hose Size

STANDARD EQUIPMENT

- Tool
- Operating Instructions and Service Manual
- Wrench (size based on options)

65NEH Series Alternate Options



Standard Lever



Safety Lever



Spade Handle





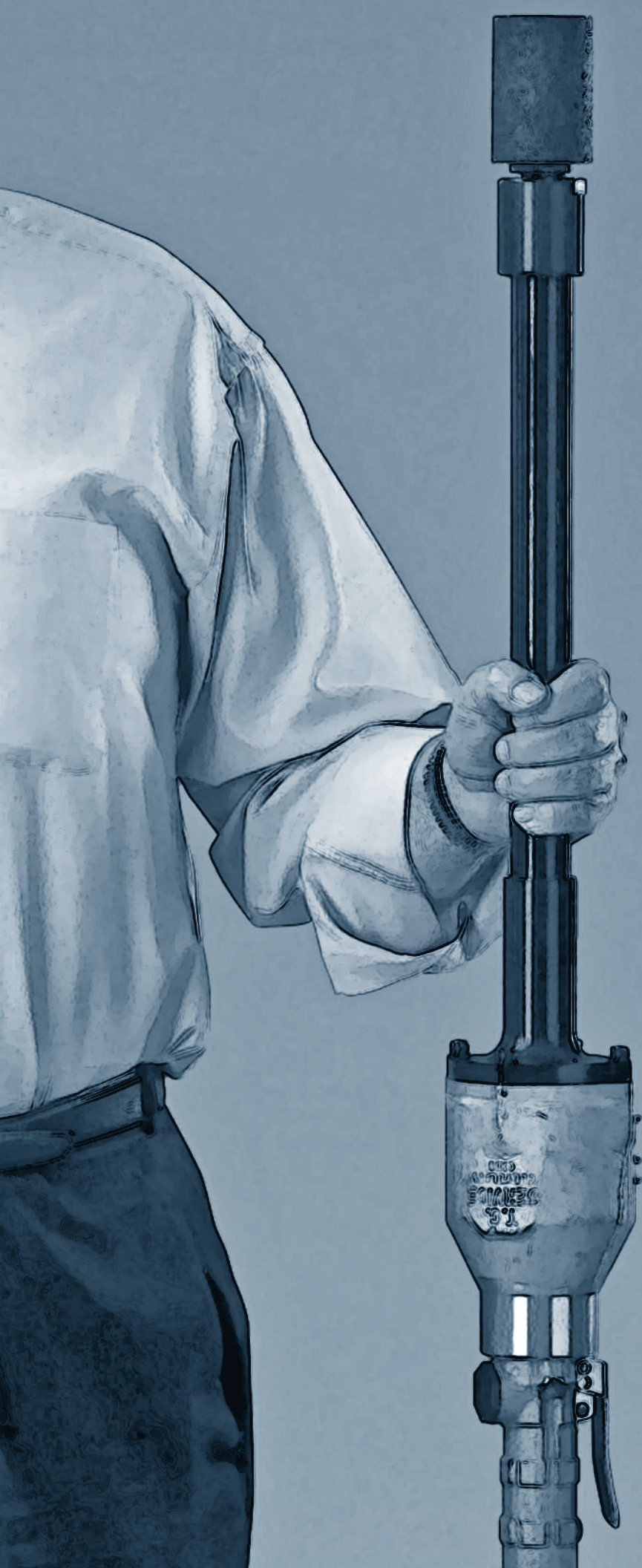



Abrasive Disk Mounting

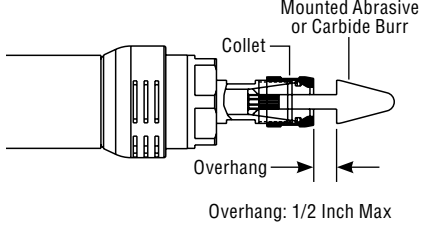

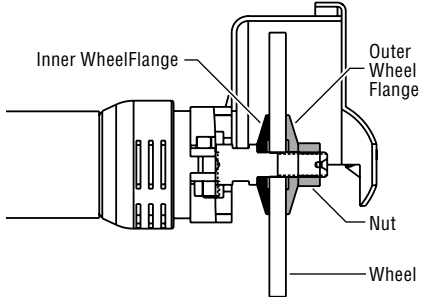

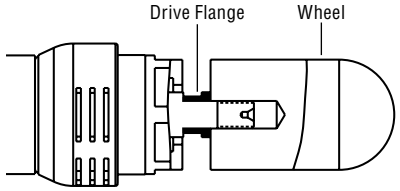
EXTENDED GRINDERS

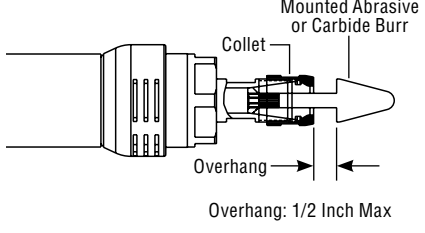
Horizontal Die Grinders

Page Number	Application	Abrasive Type/Size	Model Series	Power Output	Mounting of Abrasives
58		<ul style="list-style-type: none"> • Carbide Burrs • Mounted Stones • Flap Wheels • Sanding Abrasives w/Shank Mounting 	300GE 307GE 300HGE 307HGE	0.7 H.P. (600 W)	 <p style="text-align: center;">Overhang: 1/2 Inch Max</p>
59		<ul style="list-style-type: none"> • Carbide Burrs • Mounted Stones • Flap Wheels • Sanding Abrasives w/Shank Mounting (3/8" Shank Size Max.) 	400GE 400HGE 400GT (collet) 400HGE+3 400HGE+6	1.2 H.P. (900 W)	
60		<ul style="list-style-type: none"> • Type 1 Wheels 	400GT 407GT 400GT+3 400GT+6	1.2 H.P. (900 W)	
61		<ul style="list-style-type: none"> • Cone Wheels 	400GTCW 407GTCW	1.2 H.P. (900 W)	
62		<ul style="list-style-type: none"> • Flap Wheels • Sanding Abrasives w/Shank Mounting (3/8" Shank Size Max.) 	300HGE3M 300HGE5M 300HGE8M 400HGE3M 400HGE5M 400HGE8M	0.7 H.P. (600 W) 1.2 H.P. (900 W)	 <p style="text-align: center;">Overhang: 1/2 Inch Max</p>
63		<ul style="list-style-type: none"> • Flap Wheels • Sanding Abrasives (5/8" or 1" ID Mount) 	300GT3M 300GT5M 300GT8M 400GT3M 400GT5M 400GT8M	0.7 H.P. (600 W) 1.2 H.P. (900 W)	

See Model Page for Abrasive Mounting Details.

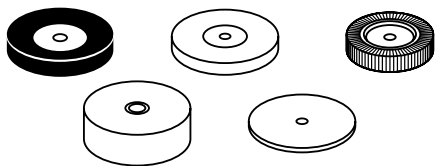

Sanding Abrasives

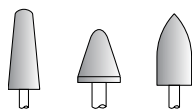

Mounted Stones



Carbide Burrs

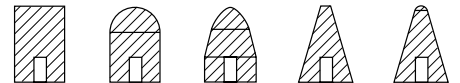

Cone Wheels

LEVER STYLE



Safety Lever Standard Lever

EXHAUST DIRECTION

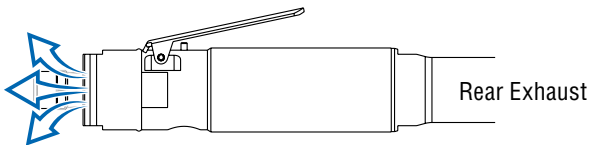
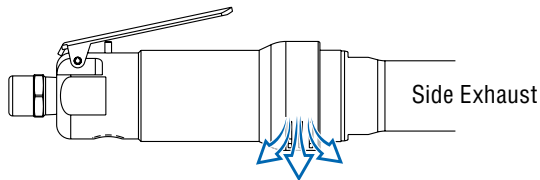

Rear exhaust overhose for the 300 Series
Only available on Rear Exhaust tools.



Rear exhaust overhose for the 400 Series
Only available on Rear Exhaust tools.

CASE MATERIAL



Aluminum Case Material Steel Case Material

The choice of case material affects the weight and durability of the tool. By its nature, aluminum is lighter in weight than steel. Steel is more durable in aggressive environments.



Die Grinders (Collet Output)

300GE Series & 307GE Series



300GEK;30000;1/4

300HGE Series & 307HGE Series



300HGE;30000;1/4

Collet Type/Capacity	Exhaust Direction	Max. Rated Speed	Lever Style	MODEL NUMBER
ER Style Insert Collet 3/8 Inch (8 mm) Maximum	Rear	30,000 RPM	Standard Lever	300GE;30000;1/4
			Safety Lever	300GEK;30000;1/4
		25,000 RPM	Standard Lever	300GE;25000;1/4
			Safety Lever	300GEK;25000;1/4
		20,000 RPM	Standard Lever	307GE;20000;1/4
			Safety Lever	307GEK;20000;1/4
18,000 RPM	Standard Lever	307GE;18000;1/4		
	Safety Lever	307GEK;18000;1/4		

Collet Type/Capacity	Exhaust Direction	Max. Rated Speed	Lever Style	MODEL NUMBER
Double Front Bearing ER Style Insert Collet 3/8 Inch (8 mm) Maximum	Rear	30,000 RPM	Standard Lever	300HGER;30000;1/4
			Safety Lever	300HGERK;30000;1/4
		25,000 RPM	Standard Lever	300HGER;25000;1/4
			Safety Lever	300HGERK;25000;1/4
		20,000 RPM	Standard Lever	307HGER;20000;1/4
			Safety Lever	307HGERK;20000;1/4
	Side	30,000 RPM	Standard Lever	300HGE;30000;1/4
			Safety Lever	300HGEK;30000;1/4
		25,000 RPM	Standard Lever	300HGE;25000;1/4
			Safety Lever	300HGEK;25000;1/4
		20,000 RPM	Standard Lever	307HGE;20000;1/4
			Safety Lever	307HGEK;20000;1/4
18,000 RPM	Standard Lever	307HGE;18000;1/4		
	Safety Lever	307HGEK;18000;1/4		

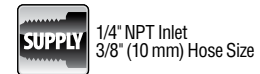
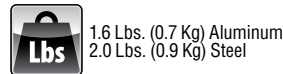
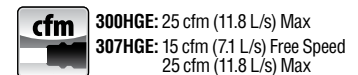
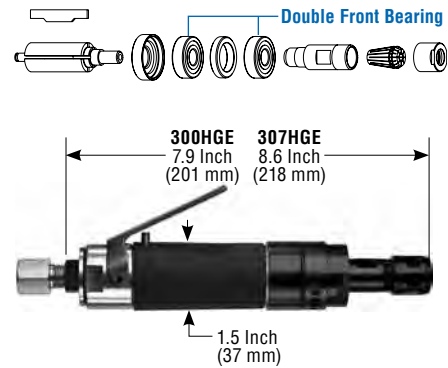
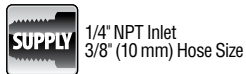
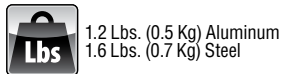
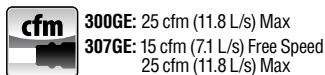
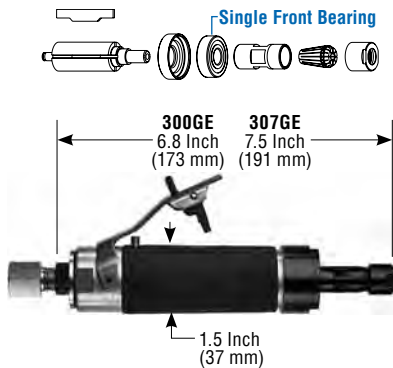

STANDARD EQUIPMENT

- Tool
- Operating Instructions and Service Manual
- Wrenches (sizes based on options)

300GE, 307GE, 300HGE & 307HGE Alternate Options

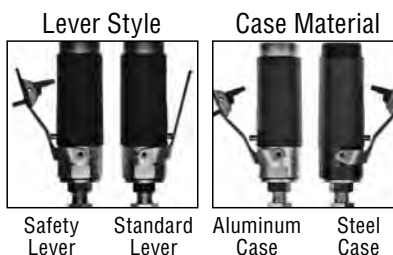

Inserted Tool Mounting



The 300GE is available with a front exhaust.

Die Grinders (Collet Output)

400GE Series



400GESK;20000;1/4

400HGE Series



400HGSR;20000;1/4

400GT Series

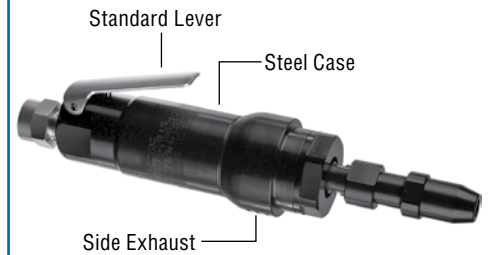

400GTS4;20000;1/4

Collet Type/Capacity	Exhaust Direction	Max. Rated Speed	Lever Style	MODEL NUMBER	Collet Type/Capacity	Exhaust Direction	Max. Rated Speed	Lever Style	MODEL NUMBER	Collet Type/Capacity	Exhaust Direction	Max. Rated Speed	Lever Style	MODEL NUMBER
ER Style Insert Collet	Side	20,000 RPM	Standard	400GES;20000;1/4	Double Front Bearing	Side	20,000 RPM	Standard	400HGES;20000;1/4	Bullet Shaped TC-1010 Collet	Side	20,000 RPM	Standard	400GTS;20000;1/4
		18,000 RPM	Safety	400GESK;20000;1/4			18,000 RPM	Safety	400HGSK;20000;1/4			18,000 RPM	Safety	400GTSK;20000;1/4
	18,000 RPM	Standard	400GES;18000;1/4	18,000 RPM		Standard	400HGES;18000;1/4	18,000 RPM	Standard		400GTS;18000;1/4			
	18,000 RPM	Safety	400GESK;18000;1/4	18,000 RPM		Safety	400HGSK;18000;1/4	18,000 RPM	Safety		400GTSK;18000;1/4			
3/8 Inch (8 mm) Maximum	Rear	20,000 RPM	Standard	400GESR;20000;1/4	ER Style Insert Collet	Rear	20,000 RPM	Standard	400HGSR;20000;1/4	1/4 Inch Only	Rear	20,000 RPM	Standard	400GTSR;20000;1/4
		18,000 RPM	Safety	400GESRK;20000;1/4			18,000 RPM	Safety	400HGRK;20000;1/4			18,000 RPM	Safety	400GTSRK;20000;1/4
	18,000 RPM	Standard	400GESR;18000;1/4	18,000 RPM		Standard	400HGSR;18000;1/4	18,000 RPM	Standard		400GTSR;18000;1/4			
	18,000 RPM	Safety	400GESRK;18000;1/4	18,000 RPM		Safety	400HGRK;18000;1/4	18,000 RPM	Safety		400GTSRK;18000;1/4			

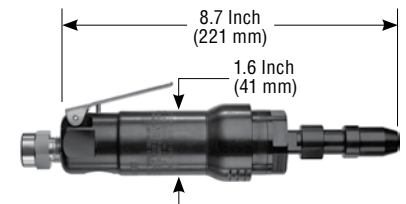
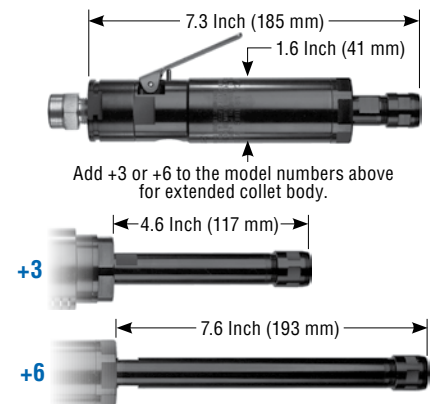
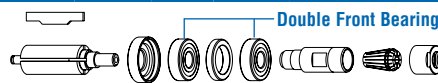
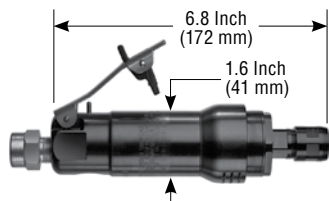

HP 1.2 H.P. (900 W)
cfm 35 cfm (16.5 L/s) Max
Lbs 1.8 Lbs. (0.8 Kg) Aluminum
2.4 Lbs. (1.1 Kg) Steel
SUPPLY 3/8" NPT Inlet
1/2" (13mm) Hose Size

HP 1.2 H.P. (900 W)
cfm 35 cfm (16.5 L/s) Max
Lbs 1.8 Lbs. (0.8 Kg) Aluminum
2.4 Lbs. (1.1 Kg) Steel
SUPPLY 3/8" NPT Inlet
1/2" (13mm) Hose Size

HP 1.2 H.P. (900 W)
cfm 35 cfm (16.5 L/s) Max
Lbs 2.0 Lbs. (0.9 Kg) Aluminum
2.6 Lbs. (1.2 Kg) Steel
SUPPLY 3/8" NPT Inlet
1/2" (13mm) Hose Size

STANDARD EQUIPMENT

- Tool
- Operating Instructions and Service Manual
- Wrenches (sizes based on options)

400GE, 400GT & 400HGE Alternate Options

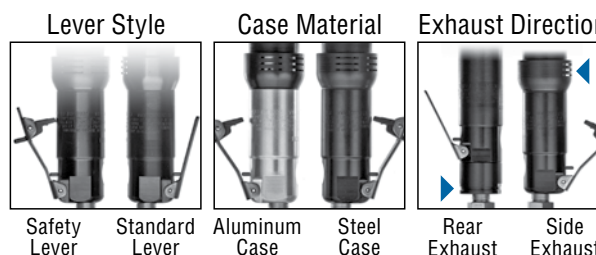

Front Exhaust option is available on all 400 Series Die Grinders.

Inserted Tool Mounting



Die Grinders (Type 1, Type 1 Cut-Off, Type 41 Wheels)

400GT / 400GT+3 / 400GT+6 Series



407GT Series



Guard/Wheel Size	Max. Rated Speed	Exhaust Direction	Lever Style	MODEL NUMBER	Guard/Wheel Size	Max. Rated Speed	Exhaust Direction	Lever Style	MODEL NUMBER
3 Inch (75 mm)	18,000 RPM	Side	Standard Lever	400GTS;18000;301	4 Inch (100 mm)	15,000 RPM	Side	Standard Lever	407GTS;15000;401
			Safety Lever	400GTSK;18000;301				Safety Lever	407GTSK;15000;401
		Rear	Standard Lever	400GTSR;18000;301					
			Safety Lever	400GTSRK;18000;301					

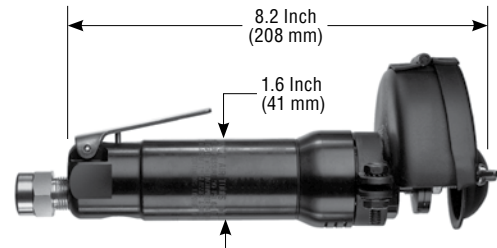
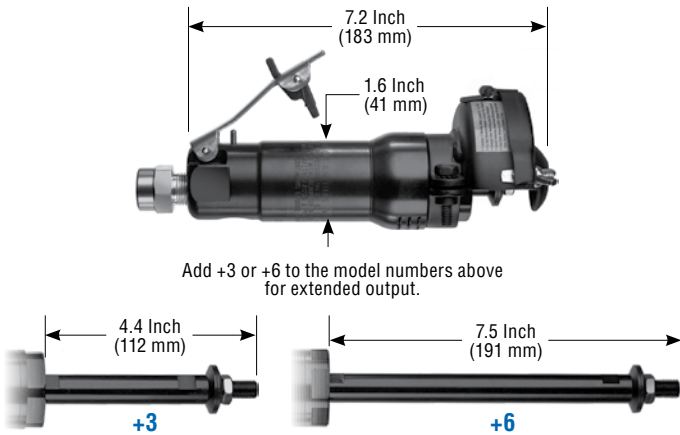

1.2 H.P. (900 W)	35 cfm (16.5 L/s) Max
2.4 Lbs. (1.1 Kg) Aluminum 3.0 Lbs. (1.4 Kg) Steel	3/8" NPT Inlet 1/2" (13mm) Hose Size

1.2 H.P. (900 W)	35 cfm (16.5 L/s) Max
2.8 Lbs. (1.3 Kg) Aluminum 3.4 Lbs. (1.5 Kg) Steel	3/8" NPT Inlet 1/2" (13mm) Hose Size

STANDARD EQUIPMENT

- Tool
- Operating Instructions and Service Manual
- Wrenches (sizes based on options)

400GT & 407GT Alternate Options

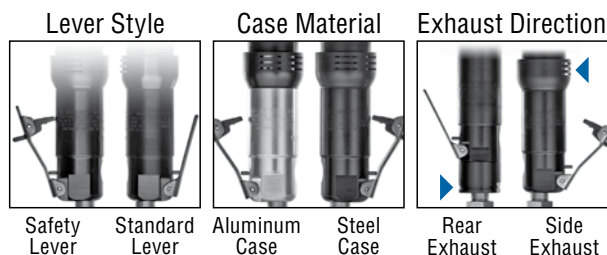

Type 1 Wheel



Die Grinders (3/8-24 Cone Wheels)

400GTCW Series

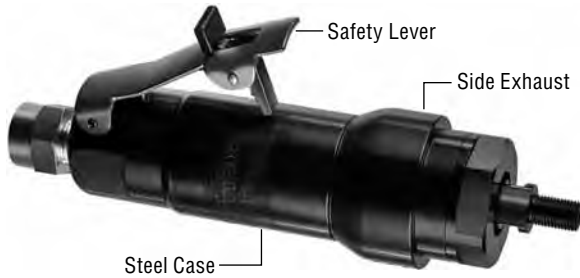

400GTSKCW;18000

407GTCW Series

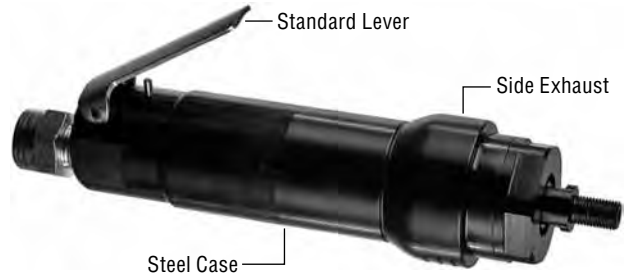

407GTSCW;15000

Max. Rated Speed	Exhaust Direction	Lever Style	MODEL NUMBER	Max. Rated Speed	Exhaust Direction	Lever Style	MODEL NUMBER		
18,000 RPM	Side	Standard Lever	400GTSCW;18000	15,000 RPM	Side	Standard Lever	407GTSCW;15000		
		Safety Lever	400GTSKCW;18000			Safety Lever	407GTSKCW;15000		
	Rear	Standard Lever	400GTSRCW;18000						
		Safety Lever	400GTSRKCW;18000						

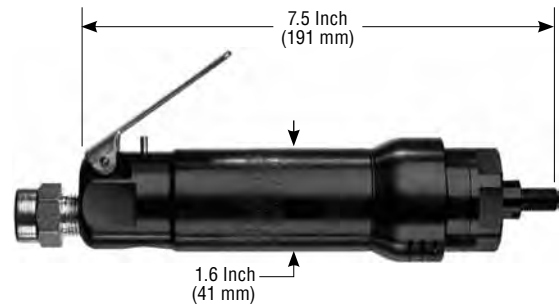
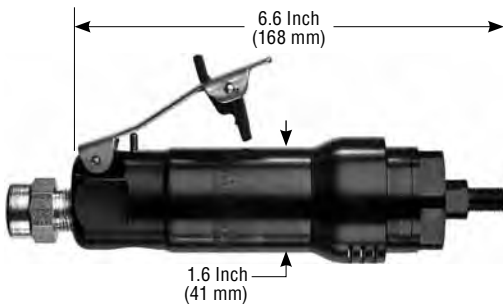

1.2 H.P. (900 W)	35 cfm (16.5 L/s) Max
1.9 Lbs. (0.9 Kg) Aluminum 2.5 Lbs. (1.1 Kg) Steel	3/8" NPT Inlet 1/2" (13mm) Hose Size

1.2 H.P. (900 W)	35 cfm (16.5 L/s) Max
2.0 Lbs. (0.9 Kg) Aluminum 2.6 Lbs. (1.2 Kg) Steel	3/8" NPT Inlet 1/2" (13 mm) Hose Size

STANDARD EQUIPMENT

- Tool
- Operating Instructions and Service Manual
- Wrenches (sizes based on options)

400GTCW & 407GTCW Alternate Options

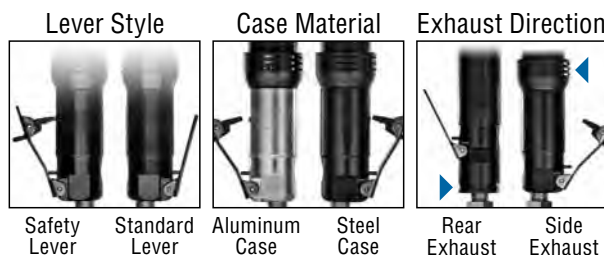

Cone Wheel Mounting



Geared Die Grinders (Collet Output)

300HGE(X)M Series

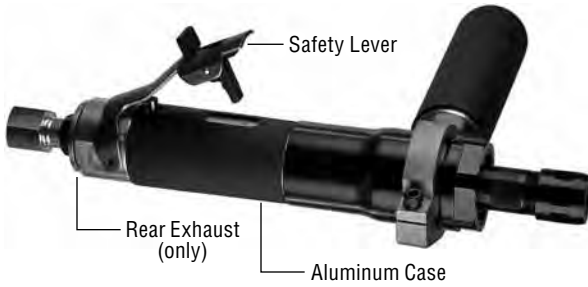

300HGE3MRK;8250;1/4

400HGE(X)M Series

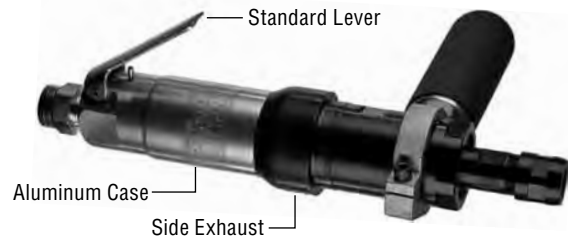

400HGE3M;5500;1/4

Output	Gear Ratio/Max. Rated Speed	Exhaust Direction	Lever Style	300HGE(X)M Series MODEL NUMBER	400HGE(X)M Series MODEL NUMBER	
Double Front Bearing ER Style Insert Collet 3/8 Inch (8 mm) Maximum	3:1 300HGE3M - 8250 RPM 400HGE3M - 5500 RPM	Side Exhaust	Standard Lever		400HGE3M;5500;1/4	
			Safety Lever		400HGE3MK;5500;1/4	
		Rear Exhaust	Standard Lever		300HGE3MR;8250;1/4	400HGE3MR;5500;1/4
			Safety Lever		300HGE3MRK;8250;1/4	400HGE3MRK;5500;1/4
	5:1 300HGE5M - 6000 RPM 400HGE5M - 4000 RPM	Side Exhaust	Standard Lever		400HGE5M;4000;1/4	
			Safety Lever		400HGE5MK;4000;1/4	
		Rear Exhaust	Standard Lever		300HGE5MR;6000;1/4	400HGE5MR;4000;1/4
			Safety Lever		300HGE5MRK;6000;1/4	400HGE5MRK;4000;1/4
	8:1 300HGE8M - 3750 RPM 400HGE8M - 2500 RPM	Side Exhaust	Standard Lever		400HGE8M;2500;1/4	
			Safety Lever		400HGE8MK;2500;1/4	
		Rear Exhaust	Standard Lever		300HGE8MR;3750;1/4	400HGE8MR;2500;1/4
			Safety Lever		300HGE8MRK;3750;1/4	400HGE8MRK;2500;1/4

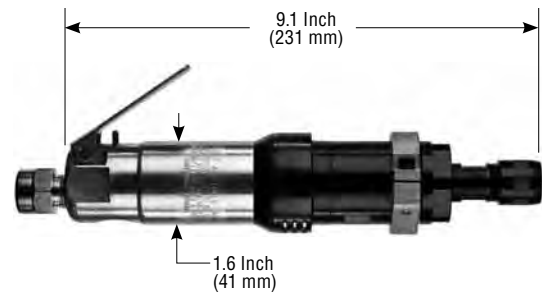
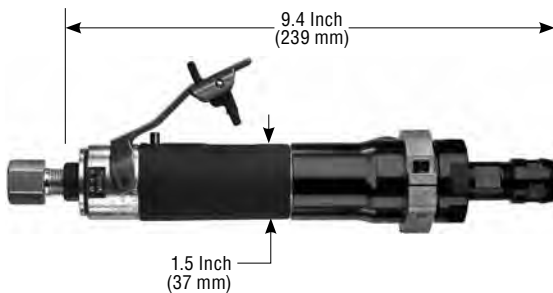

0.7 H.P.
(600 W)



25 cfm
(11.8 L/s) Max



2.4 Lbs. (1.1 Kg) Aluminum
3.0 Lbs. (1.4 Kg) Steel



1/4" NPT Inlet
3/8" (10 mm) Hose Size



1.2 H.P.
(900 W)



35 cfm
(16.5 L/s) Max



3.1 Lbs. (1.4 Kg) Aluminum
3.7 Lbs. (1.7 Kg) Steel



3/8" NPT Inlet
1/2" (13mm) Hose Size

STANDARD EQUIPMENT

- Tool
- Operating Instructions and Service Manual
- Wrenches (sizes based on options)

300HGE(X)M & 400HGE(X)M Alternate Options

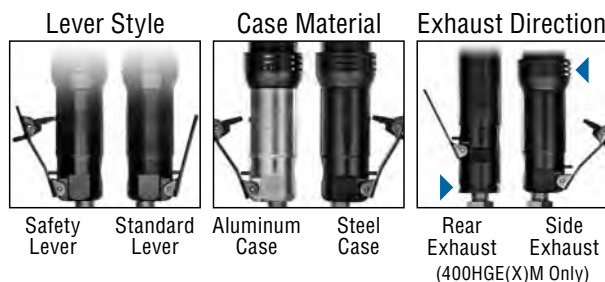

Inserted Tool Mounting



Geared Die Grinders for Surface Conditioning Abrasives

300GT(X)M Series



300GT3MK;8250;T5/8

400GT(X)M Series



400GT3M;5500;S1

Output	Gear Ratio/Max. Rated Speed	Exhaust Direction	Lever Style	300GT(X)M Series MODEL NUMBER	400GT(X)M Series MODEL NUMBER
S1 Combination Arbor 1" - 4" Wide Surface Conditioning Abrasives	3:1 300GT3M: 8250 RPM 400GT3M: 5500 RPM	Side Exhaust	Standard Lever		400GT3M;5500;S1
		Side Exhaust	Safety Lever		400GT3MK;5500;S1
		Rear Exhaust	Standard Lever	300GT3MR;8250;S1	400GT3MR;5500;S1
		Rear Exhaust	Safety Lever	300GT3MRK;8250;S1	400GT3MRK;5500;S1
	5:1 300GT5M: 6000 RPM 400GT5M: 4000 RPM	Side Exhaust	Standard Lever		400GT5M;4000;S1
		Side Exhaust	Safety Lever		400GT5MK;4000;S1
		Rear Exhaust	Standard Lever	300GT5MR;6000;S1	400GT5MR;4000;S1
		Rear Exhaust	Safety Lever	300GT5MRK;6000;S1	400GT5MRK;4000;S1
	8:1 300GT8M: 3750 RPM 400GT8M: 2500 RPM	Side Exhaust	Standard Lever		400GT8M;2500;S1
		Side Exhaust	Safety Lever		400GT8MK;2500;S1
		Rear Exhaust	Standard Lever	300GT8MR;3750;S1	400GT8MR;2500;S1
		Rear Exhaust	Safety Lever	300GT8MRK;3750;S1	400GT8MRK;2500;S1
T5/8 Mounting Wheels That Have a 5/8-11 Thread	3:1 300GT3M: 8250 RPM 400GT3M: 5500 RPM	Side Exhaust	Standard Lever		400GT3M;5500;T5/8
		Side Exhaust	Safety Lever		400GT3MK;5500;T5/8
		Rear Exhaust	Standard Lever	300GT3MR;8250;T5/8	400GT3MR;5500;T5/8
		Rear Exhaust	Safety Lever	300GT3MRK;8250;T5/8	400GT3MRK;5500;T5/8
	5:1 300GT5M: 6000 RPM 400GT5M: 4000 RPM	Side Exhaust	Standard Lever		400GT5M;4000;T5/8
		Side Exhaust	Safety Lever		400GT5MK;4000;T5/8
		Rear Exhaust	Standard Lever	300GT5MR;6000;T5/8	400GT5MR;4000;T5/8
		Rear Exhaust	Safety Lever	300GT5MRK;6000;T5/8	400GT5MRK;4000;T5/8
	8:1 300GT8M: 3750 RPM 400GT8M: 2500 RPM	Side Exhaust	Standard Lever		400GT8M;2500;T5/8
		Side Exhaust	Safety Lever		400GT8MK;2500;T5/8
		Rear Exhaust	Standard Lever	300GT8MR;3750;T5/8	400GT8MR;2500;T5/8
		Rear Exhaust	Safety Lever	300GT8MRK;3750;T5/8	400GT8MRK;2500;T5/8

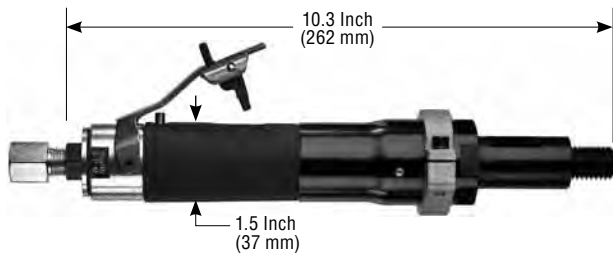

0.7 H.P. (600 W)	25 cfm (11.8 L/s) Max
2.8 Lbs. (1.3 Kg) Aluminum 3.5 Lbs. (1.6 Kg) Steel	1/4" NPT Inlet 3/8" (10 mm) Hose Size

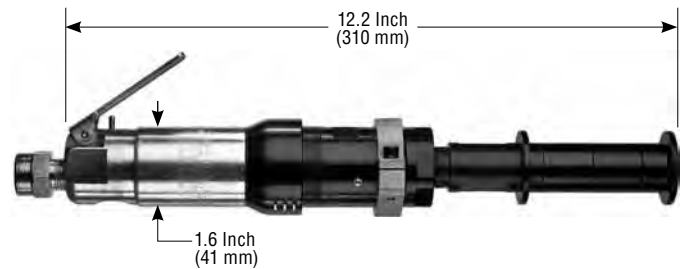

1.2 H.P. (900 W)	35 cfm (16.5 L/s) Max
3.9 Lbs (1.8 Kg) Aluminum 4.5 Lbs (2.0 Kg) Steel	3/8" NPT Inlet 1/2" (13 mm) Hose Size

STANDARD EQUIPMENT

- Tool
- Operating Instructions and Service Manual
- Wrenches (sizes based on options)







300GT(X)M & 400GT(X)M Alternate Options

Lever Style		Case Material		Exhaust Direction	
Safety Lever	Standard Lever	Aluminum Case	Steel Case	Rear Exhaust	Side Exhaust (400GT(X)M Only)

Sanding Abrasive Mounting

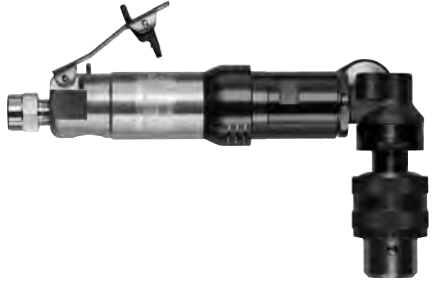

Air Drills

Page Number	Model Number	Power	Maximum Operating Speed	Description		
66	300D(X)M	0.7 HP (600 W)	825-8250 RPM	Inline Drills		
	400D(X)M	1.2 HP (900 W)	550-5500 RPM			
67	400D(X)MP	1.2 HP (900 W)	550-5500 RPM			
	500D2M	1.5 HP (1.1 kW)	1000 RPM			
68	300DRA(X)M	0.7 HP (600 W)	390-4000 RPM		Right Angle Drills	
	300DRAE(X)M					
	400DRA(X)M	1.2 HP (900 W)	260-2900 RPM			
	400DRAE(X)M					
69	400FD(X)M	1.2 HP (900 W)	550-5500 RPM	Floor Drills		
	500FD1M	1.5 HP (1.1 kW)	4000 RPM			

EXTENDED NECK VS STANDARD

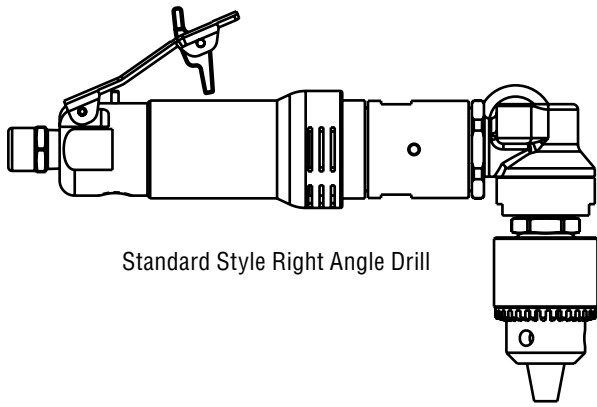

Standard Style Right Angle Drill

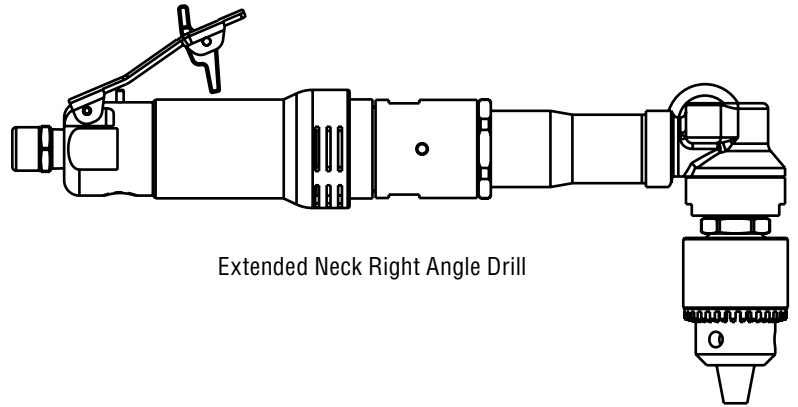

Extended Neck Right Angle Drill

CASE MATERIAL

The choice of case material affects the weight and durability of the tool. By its nature, aluminum is lighter in weight than steel. Steel is more durable in aggressive environments.



Aluminum Case Material Steel Case Material

LEVER STYLE



Safety Lever Standard Lever

EXHAUST DIRECTION

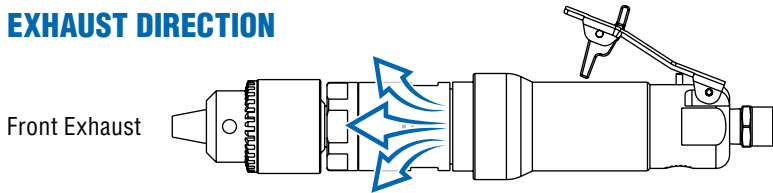

Front Exhaust

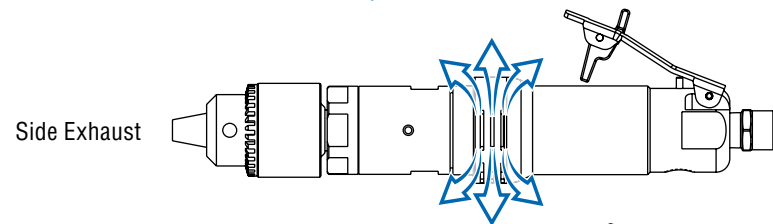

Side Exhaust

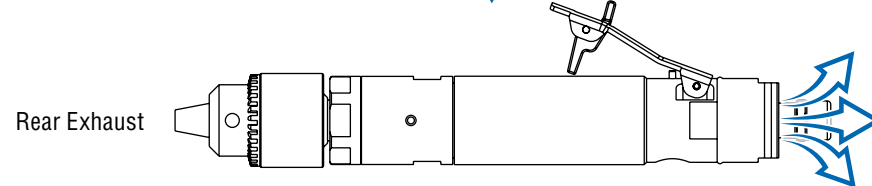

Rear Exhaust



Rear exhaust overhose for the 300 Series
Only available on Rear Exhaust tools.



Rear exhaust overhose for the 400 Series
Only available on Rear Exhaust tools.

Inline Air Drills

300D(X)M Series

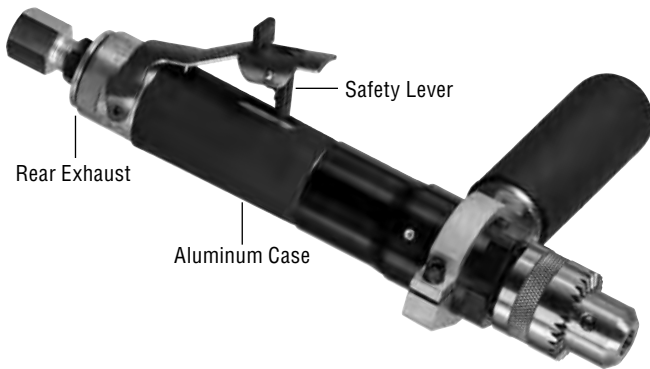
300D3MK;8250;D3/8

400D(X)M Series

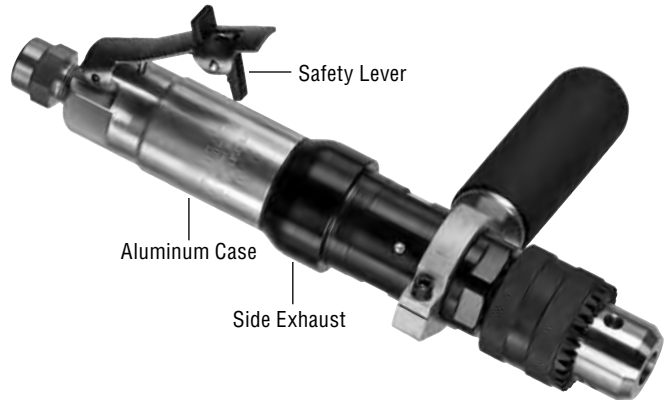
400D3MK;5500;D1/2

Output	Gear Ratio/Rated Speed	Lever Style	300 Series MODEL NUMBER	400 Series MODEL NUMBER
300 Series: 3/8" (10 mm) Drill Chuck 400 Series: 1/2" (13 mm) Drill Chuck	3:1 300 Series: 8250 RPM 400 Series: 5500 RPM	Standard Lever	300D3M;8250;D3/8	400D3M;5500;D1/2
		Safety Lever	300D3MK;8250;D3/8	400D3MK;5500;D1/2
	5:1 300 Series: 6000 RPM 400 Series: 4000 RPM	Standard Lever	300D5M;6000;D3/8	400D5M;4000;D1/2
		Safety Lever	300D5MK;6000;D3/8	400D5MK;4000;D1/2
	8:1 300 Series: 3750 RPM 400 Series: 2500 RPM	Standard Lever	300D8M;3750;D3/8	400D8M;2500;D1/2
		Safety Lever	300D8MK;3750;D3/8	400D8MK;2500;D1/2
	21:1 300 Series: 1350 RPM 400 Series: 900 RPM	Standard Lever	300D21M;1350;D3/8	400D21M;900;D1/2
		Safety Lever	300D21MK;1350;D3/8	400D21MK;900;D1/2
	36:1 300 Series: 825 RPM 400 Series: 550 RPM	Standard Lever	300D36M;825;D3/8	400D36M;550;D1/2
		Safety Lever	300D36MK;825;D3/8	400D36MK;550;D1/2

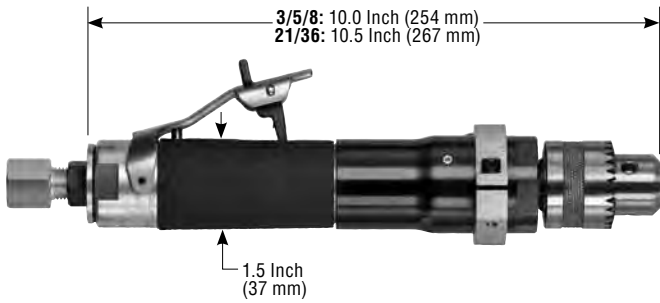
 0.7 H.P.
(600 kW)

 25 cfm
(11.8 L/s) Max

 3/5/8: 3.2 Lbs. (1.4 Kg)
21/36: 3.4 Lbs (1.5 Kg)

 1/4" NPT Inlet
3/8" (10 mm) Hose Size

 1.2 H.P.
(900 W)

 35 cfm
(16.5 L/s) Max

 3/5/8: 4.1 Lbs. (1.9 Kg)
21/36: 4.3 Lbs (1.9 Kg)

 3/8" NPT Inlet
1/2" (13 mm) Hose Size

STANDARD EQUIPMENT

- Tool
- Operating Instructions and Service Manual

300D(X)M & 400D(X)M Series Alternate Options

Case Material



Aluminum Case Steel Case

Lever Style



Safety Lever Regular Lever

Pistol Grip Air Drills
400D(X)MP Series

400D3MP;5500;D1/2
500D2M Series

500D2M;1000;D3/4

Output	Gear Ratio / Rated Speed	MODEL NUMBER	Output	Gear Ratio / Rated Speed	MODEL NUMBER
1/2" (13 mm) Drill Chuck	3:1 / 5500 RPM	400D3MP;5500;D1/2	1/2" (13 mm) Drill Chuck	16:1 / 1000 RPM	500D2M;1000;D1/2
	5:1 / 4000 RPM	400D5MP;4000;D1/2	3/4" (19 mm) Drill Chuck		500D2M;1000;D3/4
	8:1 / 2500 RPM	400D8MP;2500;D1/2			
	21:1 / 900 RPM	400D21MP;900;D1/2			
	36:1 / 550 RPM	400D36MP;550;D1/2			

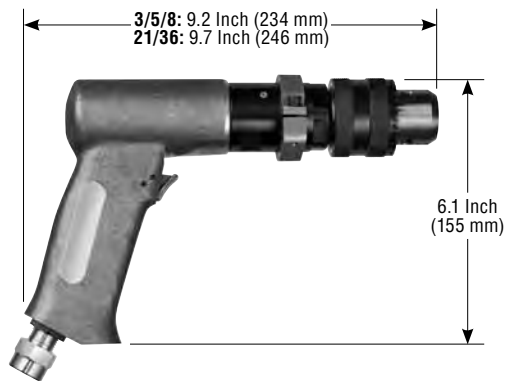

1.2 H.P. (900 W)
 3/5/8: 4.4 Lbs. (2.0 Kg)
 21/36: 4.6 Lbs (2.1 Kg)

35 cfm (16.5 L/s) Max
 3/8" NPT Inlet
 1/2" (13mm) Hose Size

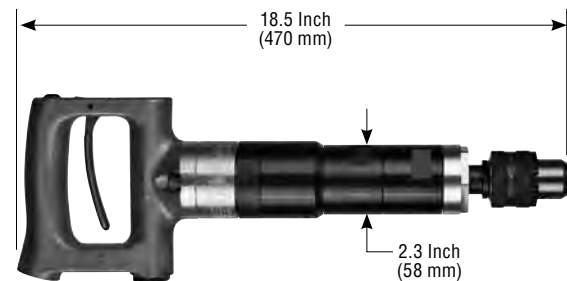

1.5 H.P. (1125 W)
 11.0 Lbs. (5.0 Kg)

35 cfm (16.5 L/s) Max
 1/2" NPT Inlet
 1/2" (13mm) Hose Size

STANDARD EQUIPMENT

- Tool
- Operating Instructions and Service Manual

Right Angle Drills

300DRA(X)M & 300DRAE(X)M Series

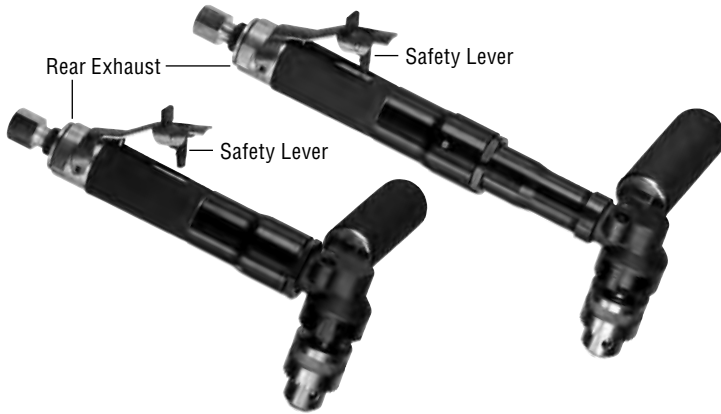

300DRA3MK;4000;D3/8

300DRAE3MK;4000;D3/8

400DRA(X)M & 400DRAE(X)M Series

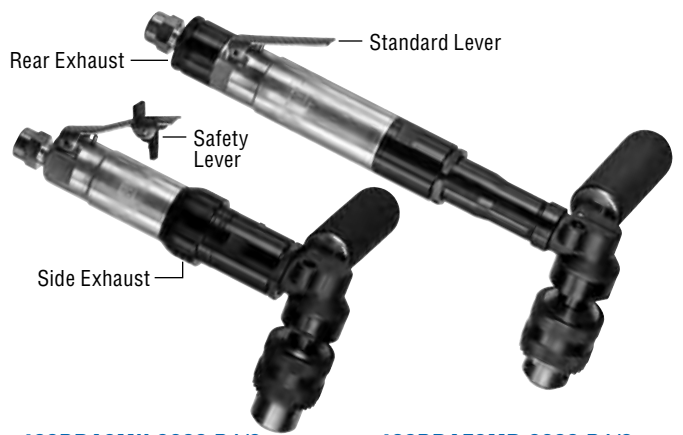

400DRA3MK;2900;D1/2

400DRAE3MR;2900;D1/2

Output	Gear Ratio/Rated Speed	Lever Style	300DRA(X)M MODEL NUMBER	300DRAE(X)M MODEL NUMBER	400DRA(X)M MODEL NUMBER	400DRAE(X)M MODEL NUMBER
300 Series 3/8" (10 mm) Drill Chuck	3:1 300 Series: 4000 RPM 400 Series: 2900 RPM	Standard Lever	300DRA3M;4000;D3/8	300DRAE3M;4000;D3/8	400DRA3M;2900;D1/2	400DRAE3M;2900;D1/2
		Safety Lever	300DRA3MK;4000;D3/8	300DRAE3MK;4000;D3/8	400DRA3MK;2900;D1/2	400DRAE3MK;2900;D1/2
	5:1 300 Series: 3000 RPM 400 Series: 2200 RPM	Standard Lever	300DRA5M;3000;D3/8	300DRAE5M;3000;D3/8	400DRA5M;2200;D1/2	400DRAE5M;2200;D1/2
		Safety Lever	300DRA5MK;3000;D3/8	300DRAE5MK;3000;D3/8	400DRA5MK;2200;D1/2	400DRAE5MK;2200;D1/2
400 Series 1/2" (13 mm) Drill Chuck	8:1 300 Series: 1800 RPM 400 Series: 1300 RPM	Standard Lever	300DRA8M;1800;D3/8	300DRAE8M;1800;D3/8	400DRA8M;1300;D1/2	400DRAE8M;1300;D1/2
		Safety Lever	300DRA8MK;1800;D3/8	300DRAE8MK;1800;D3/8	400DRA8MK;1300;D1/2	400DRAE8MK;1300;D1/2
	21:1 300 Series: 660 RPM 400 Series: 440 RPM	Standard Lever	300DRA21M;660;D3/8	300DRAE21M;660;D3/8	400DRA21M;440;D1/2	400DRAE21M;440;D1/2
		Safety Lever	300DRA21MK;660;D3/8	300DRAE21MK;660;D3/8	400DRA21MK;440;D1/2	400DRAE21MK;440;D1/2
36:1 300 Series: 390 RPM 400 Series: 260 RPM	Standard Lever	300DRA36M;390;D3/8	300DRAE36M;390;D3/8	400DRA36M;260;D1/2	400DRAE36M;260;D1/2	
	Safety Lever	300DRA36MK;390;D3/8	300DRAE36MK;390;D3/8	400DRA36MK;260;D1/2	400DRAE36MK;260;D1/2	

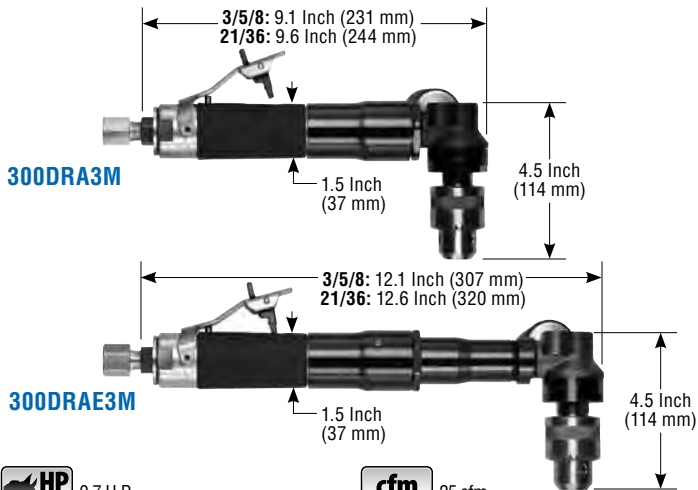

HP 0.7 H.P. (600 kW)

cfm 25 cfm (11.8 L/s) Max

Lbs 3/5/8: 3.7 Lbs. (1.7 Kg): Short
21/36: 3.9 Lbs. (1.8 Kg): Short
3/5/8: 4.3 Lbs. (1.9 Kg): Extended
21/36: 4.5 Lbs. (2.0 Kg): Extended

SUPPLY 1/4" NPT Inlet
3/8" (10 mm) Hose Size

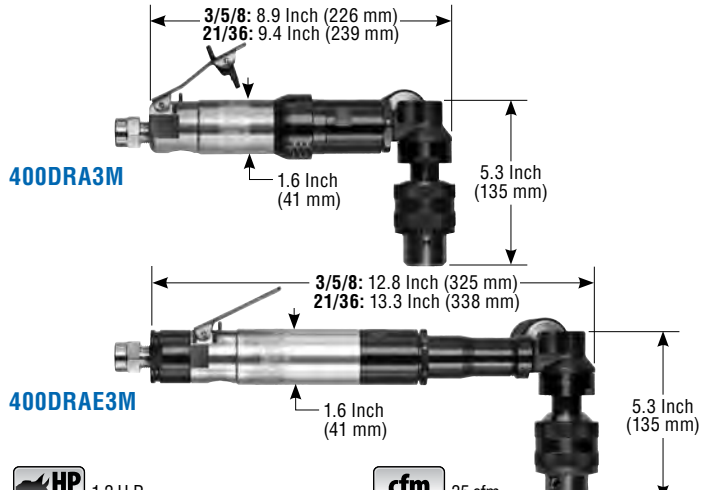

HP 1.2 H.P. (900 W)

cfm 35 cfm (16.5 L/s) Max

Lbs 3/5/8: 4.5 Lbs. (2.0 Kg): Short
21/36: 4.7 Lbs. (2.1 Kg): Short
3/5/8: 5.1 Lbs. (2.3 Kg): Extended
21/36: 5.3 Lbs. (2.4 Kg): Extended

SUPPLY 3/8" NPT Inlet
1/2" (13 mm) Hose Size

STANDARD EQUIPMENT

- Tool
- Operating Instructions and Service Manual

300DRA(X)M, 300DRAE(X)M, 400DRA(X)M, 400DRAE(X)M Series Alternate Options

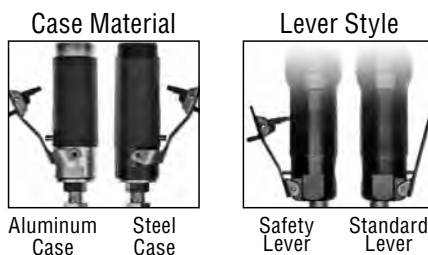

Aluminum Case

Steel Case

Safety Lever

Standard Lever

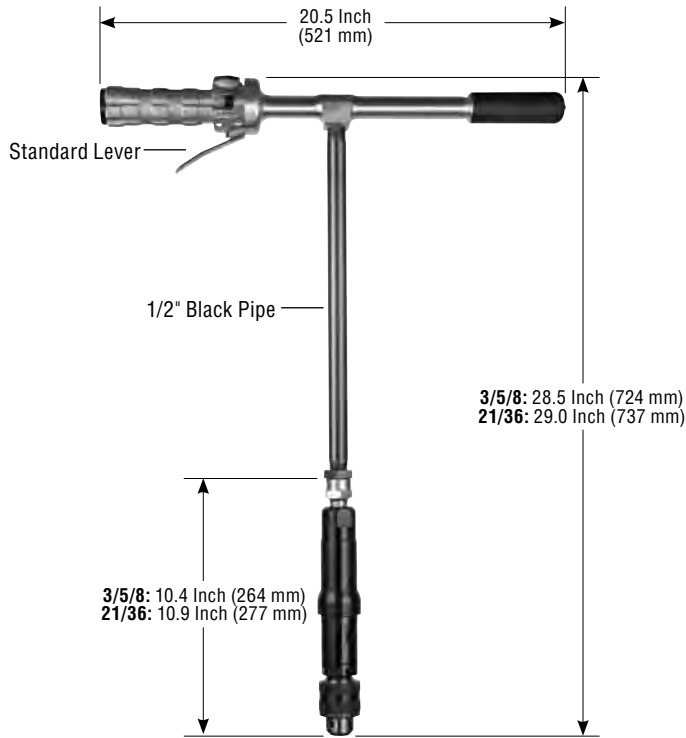
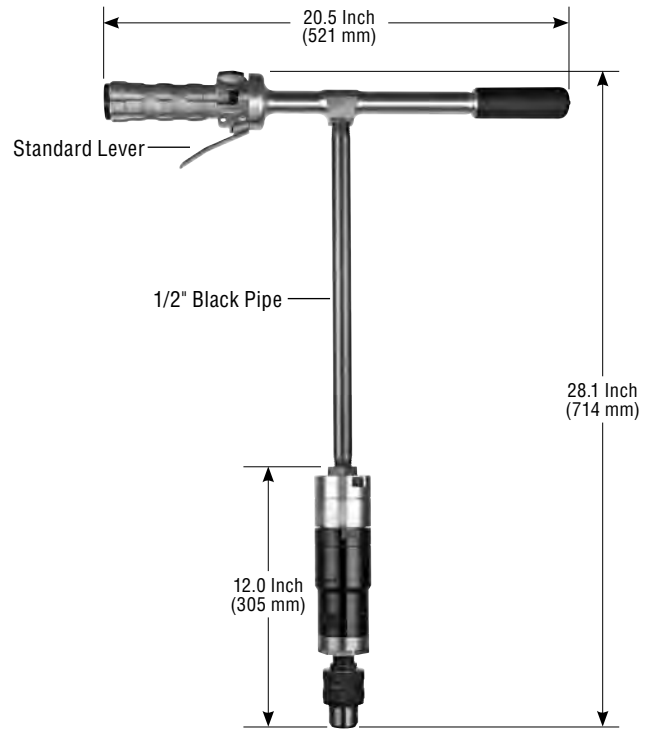
Floor Drills
400FD(X)M Series

400FD3ML;5500;D1/2;P15
500FD1M Series

500FD1ML;4000;D1/2;P15

Output	Gear Ratio / Rated Speed	Lever Style	MODEL NUMBER	Output	Gear Ratio / Rated Speed	MODEL NUMBER				
1/2" (13 mm) Drill Chuck	3:1 / 5500 RPM	Standard Lever	400FD3M;5500;D1/2;P15	1/2" (13 mm) Drill Chuck	4:1 / 4000 RPM	500FD1ML;4000;D1/2;P15				
		Safety Lever	400FD3MK;5500;D1/2;P15							
	5:1 / 4000 RPM	Standard Lever	400FD5M;4000;D1/2;P15	1/2" (13 mm) Drill Chuck	4:1 / 4000 RPM		500FD1ML;4000;D1/2;P15			
		Safety Lever	400FD5MK;4000;D1/2;P15							
	8:1 / 2500 RPM	Standard Lever	400FD8M;2500;D1/2;P15	1/2" (13 mm) Drill Chuck	4:1 / 4000 RPM			500FD1ML;4000;D1/2;P15		
		Safety Lever	400FD8MK;2500;D1/2;P15							
	21:1 / 900 RPM	Standard Lever	400FD21M;900;D1/2;P15	1/2" (13 mm) Drill Chuck	4:1 / 4000 RPM				500FD1ML;4000;D1/2;P15	
		Safety Lever	400FD21MK;900;D1/2;P15							
	36:1 / 550 RPM	Standard Lever	400FD36M;550;D1/2;P15	1/2" (13 mm) Drill Chuck	4:1 / 4000 RPM					500FD1ML;4000;D1/2;P15
		Safety Lever	400FD36MK;550;D1/2;P15							

1.2 H.P. (900 W)
 3/5/8: 8.3 Lbs. (3.8 Kg)
 21/36: 8.5 Lbs (3.8 Kg)

35 cfm (16.5 L/s) Max
 1/2" NPT Inlet
 3/8" (10mm) Hose Size

1.5 H.P. (1125 W)
 10.8 Lbs (4.9 Kg)

35 cfm (16.5 L/s) Max
 1/2" NPT Inlet
 1/2" (13mm) Hose Size

STANDARD EQUIPMENT

- Tool
- Operating Instructions and Service Manual

Belt Sander

300BL/K

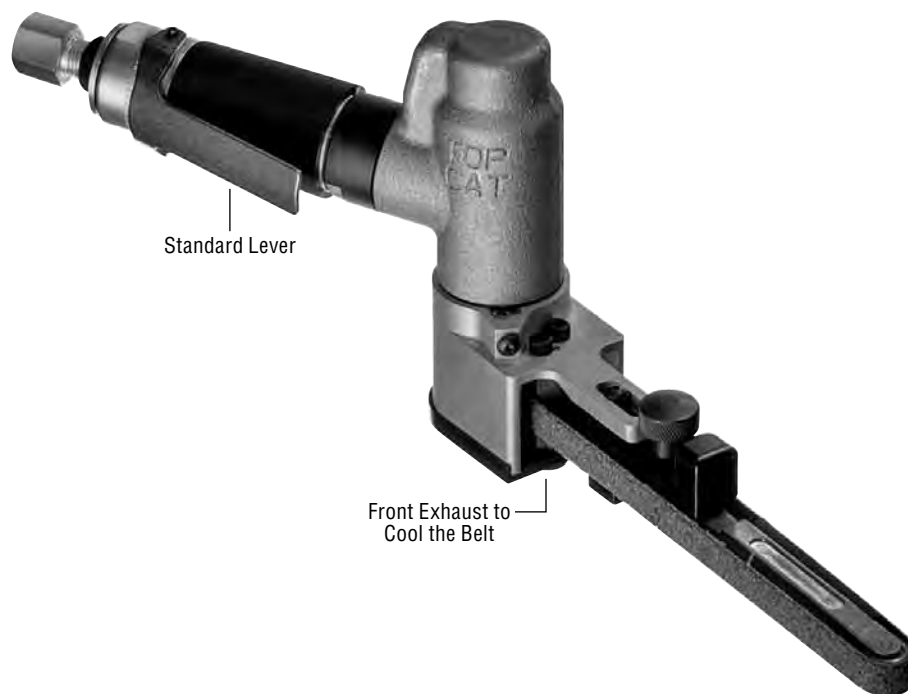

Belt Capacity	Max. SFPM	Lever Style	Model Number
5/8 or 3/4 Inch X 18 Inch	5700 SFPM	Standard Lever	300BL
		Safety Lever	300BK

The 300B Series is offered in a version with a 4550 Max SFPM.

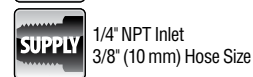
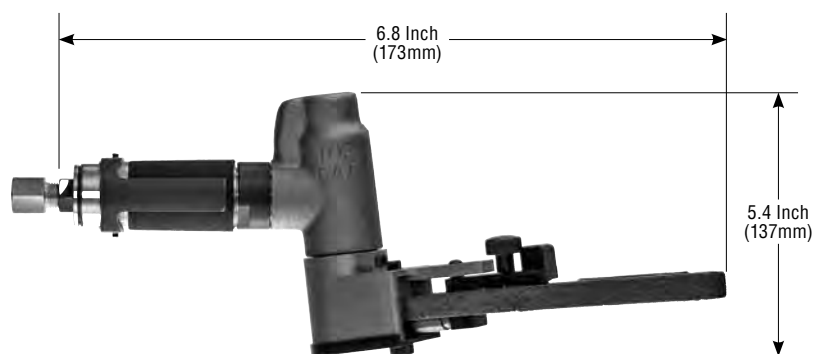

STANDARD EQUIPMENT

- Tool
- Operating Instructions and Service Manual
- Wrenches (sizes based on options)

Bench Grinder

66BVG

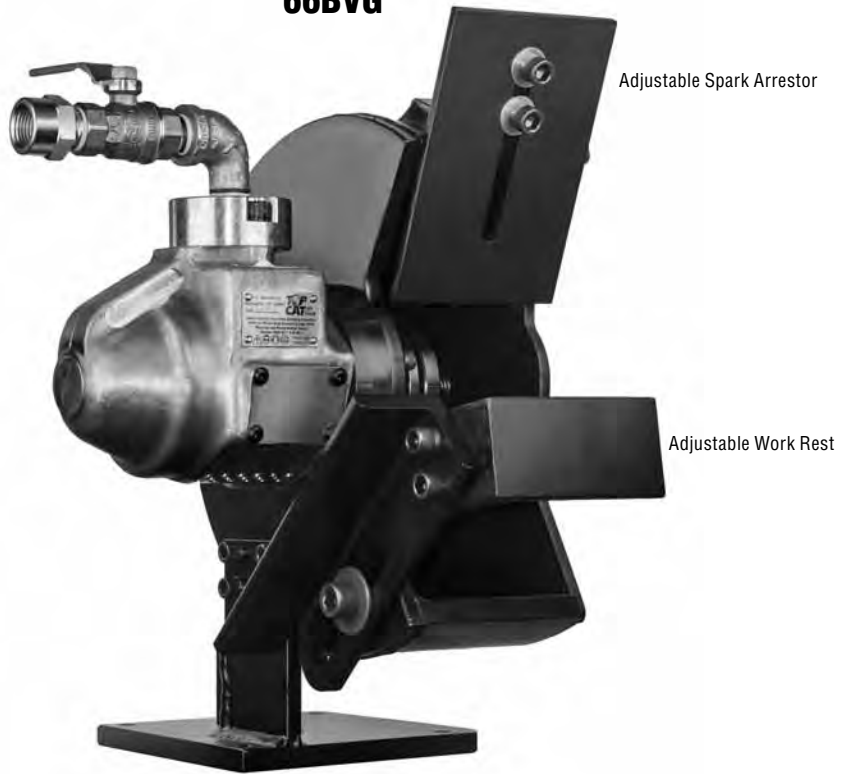

MODEL NUMBER
66BVG;6000;9

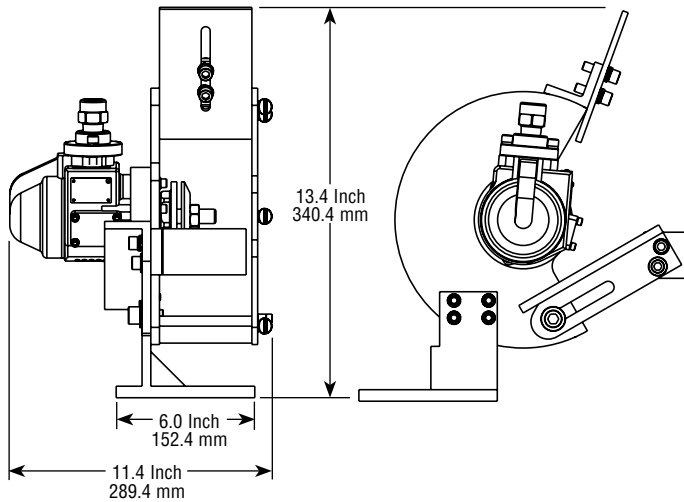

HP 4.0 H.P.
(3000 W)

Lbs 51.0 Lbs (23.0 Kg)

cfm 25 cfm (11.8 L/s) Free
75 cfm (35.4 L/s) Max

SUPPLY 1/2" NPT Inlet
1/2" (13mm) Hose Size

STANDARD EQUIPMENT

- Tool
- Operating Instructions and Service Manual
- Wrenches (sizes based on options)



Reinforced Type 1 Cut-Off Wheel (Type 41)



Diamond Wheel

Abrasive Cutting Tools



65VBW;5000;12

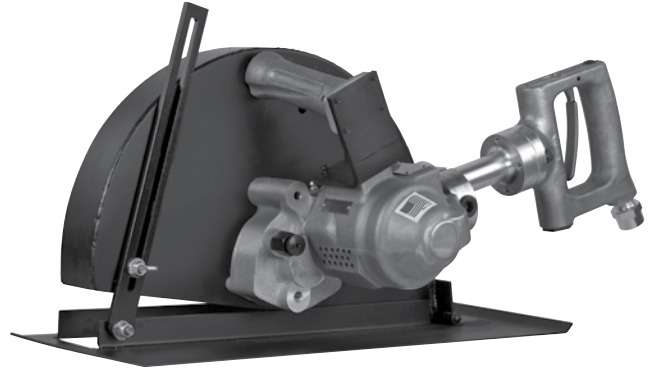

662VBW;3300;14

Guard Size	Spindle Type	Operating Speed	MODEL NUMBER	Guard Size	Spindle Type	Operating Speed	MODEL NUMBER
9 Inch	5/8-11	6000 RPM	65VBW;6000;941				
12 Inch	1" Spline	5000 RPM	65VBW;5000;1241	12 Inch	1" Spline	3300 RPM	662VBW;3300;1241
14 Inch		4000 RPM	65VBW;4000;1441	14 Inch			662VBW;3300;1441

Dimensions shown are for 12" guard. Other guards vary slightly.

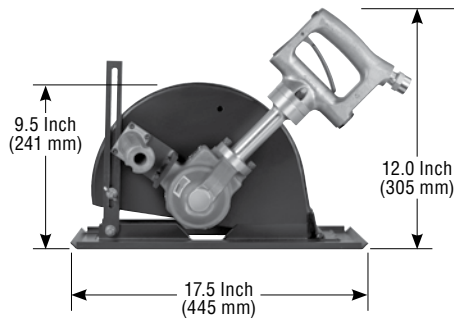

Dimensions shown are for 14" guard. Other guards vary slightly.

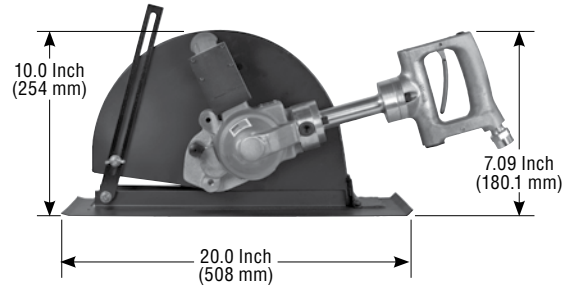

4.0 H.P.
(3000 W)



25 cfm (11.8 L/s) Free
75 cfm (35.4 L/s) Max



65VBW: 23.9 Lbs. (10.8 Kg)
662VBW: 28.3 Lbs. (12.8 Kg)



1/2" NPT Inlet
1/2" (13mm) Hose Size

STANDARD EQUIPMENT

- Tool
- Operating Instructions and Service Manual
- Wrenches (sizes based on options)





Model Number	Depth of Cut		
	Guard Size		
	9 Inch (230mm)	12 Inch (300mm)	14 inch (360mm)
65VBW	2.5 Inch (64mm)	3.3 Inch (84mm)	4.3 Inch (109mm)
662VBW	N/A		



Wet Cutting Attachment







Scalers & Needle Scalers

SCALERS Page Number	Tool Configuration	Model Series
75	<ul style="list-style-type: none"> • 1/2 Square Style Chisel  	TC-1
	<ul style="list-style-type: none"> • 1/4 Octagon Style Chisel  	TC-182
NEEDLE SCALERS Page Number	Tool Configuration	Model Series
76	<ul style="list-style-type: none"> • 1/2 Square Style Chisel  	TC-1-N
	<ul style="list-style-type: none"> • 1/4 Octagon Style Chisel  	TC-182-N

HANDLES



Chipping Hammers

CHIPPING HAMMERS Page Number	Tool Configuration	Model Series
77	<ul style="list-style-type: none"> • 0.401 Round Shank Chisel  • 0.371 Hex Shank Chisel  	80 Series
	<ul style="list-style-type: none"> • 0.680 Round Shank Chisel  • 0.580 Hex Shank Chisel  	TC-183

METHODS OF CHISEL RETENTION

80 Series

Beehive Retainer

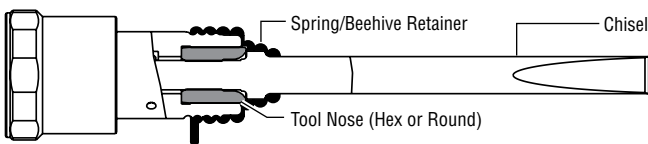

TC-183 Series

Chisel Retainer

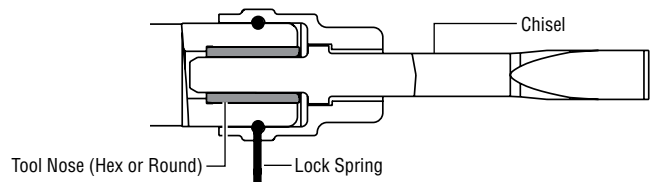

Scalers

TC-1 Series



TC-1-L

Spring Style Chisel Retainer



Standard Lever



Safety Lever



Push Handle



Pistol Handle



Flow Through Handle

TC-182 Series



TC-182-L

Collar Style Chisel Retainer

Chisel Type	Handle Type	MODEL NUMBER	Chisel Type	Handle Type	MODEL NUMBER
 1/2" Square	Lever	TC-1-L	 1/4" Octagon	Lever	TC-182-L
	Safety Lever	TC-1-K		Safety Lever	TC-182-K
	Push	TC-1-P		Push	TC-182-P
	Pistol	TC-1-W		Pistol	TC-182-W
	Flow Through	TC-1-FT		Flow Through	TC-182-FT
Pipe-Extended Lever	TC-1-FL;PL48	Pipe-Extended Lever	TC-182-FL;PL48		



Floor Scraper
TC-1-FL;PL48

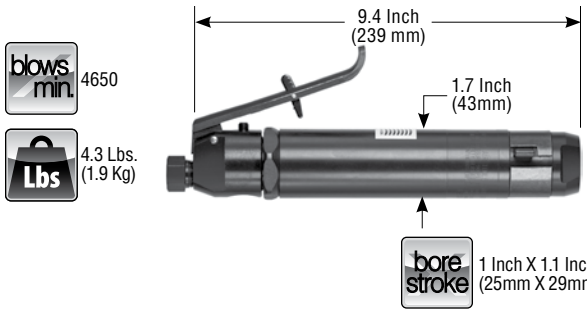

blows min. 4650

Lbs 4.3 Lbs. (1.9 Kg)

9.4 Inch (239 mm)

1.7 Inch (43 mm)

bore stroke 1 Inch X 1.1 Inch (25mm X 29mm)

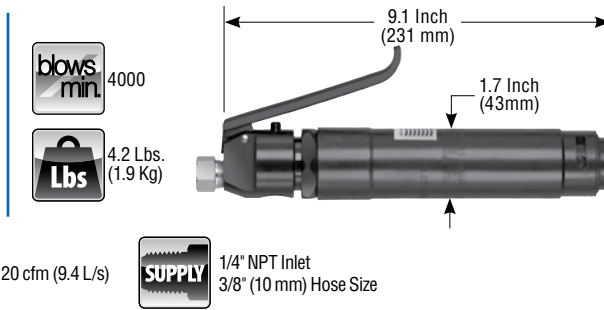

blows min. 4000

Lbs 4.2 Lbs. (1.9 Kg)

9.1 Inch (231 mm)

1.7 Inch (43 mm)

20 cfm (9.4 L/s)

SUPPLY 1/4" NPT Inlet
3/8" (10 mm) Hose Size

Chisels – 1/2 Inch Square Shank

Description	Cutting Edge	Overall Length	Part Number
Narrow Flat Chisel	3/4" (19mm)	7" (178mm)	839051
Narrow Flat Chisel	3/4" (19mm)	12" (305mm)	839341
Narrow Flat Chisel	3/4" (19mm)	18" (457mm)	839335
Wide Angle Chisel	1 3/8" (34.9mm)	7" (178mm)	839050
Wide Angle Chisel	1 3/8" (34.9mm)	12" (305mm)	839299
Wide Angle Chisel	1 3/8" (34.9mm)	18" (457mm)	839334
Blank Chisel	7" (178mm)	839052	
Blank Chisel	12" (305mm)	839053	
Blank Chisel	18" (457mm)	839054	
Wide Chisel	1 3/8" (34.9mm)	7" (178mm)	839467
Wide Chisel	1 3/8" (34.9mm)	12" (305mm)	839469
2 Inch Wide Scraper	2" (50.8mm)	7" (178mm)	839468

Other Sizes And Styles Available

Chisels – 1/4 Inch Octagon

Description	Cutting Edge	Overall Length	Part Number
Narrow Flat Chisel	3/4" (19mm)	7" (17.8cm)	839601
Narrow Flat Chisel	3/4" (19mm)	12" (30.5cm)	839601-12
Blank Chisel	7" (17.8cm)	839605	
Blank Chisel	12" (30.5cm)	839605-12	
Wide Chisel	1 3/8" (34.9mm)	7" (17.8cm)	839602
Wide Angle Chisel	1 3/8" (34.9mm)	7" (17.8cm)	839604
Wide Angle Chisel	1 3/8" (34.9mm)	12" (30.5cm)	839604-12

Other Sizes And Styles Available

Needle Scalers

TC-1 Series



TC-1-NL

TC-182 Series



TC-182-NL



Standard Lever

Safety Lever

Push Handle

Pistol Handle

Flow Through Handle

Handle Type	MODEL NUMBER	Handle Type	MODEL NUMBER
Lever	TC-1-NL	Lever	TC-182-NL
Safety Lever	TC-1-NK	Safety Lever	TC-182-NK
Push	TC-1-NP	Push	TC-182-NP
Pistol	TC-1-NW	Pistol	TC-182-NW

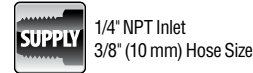
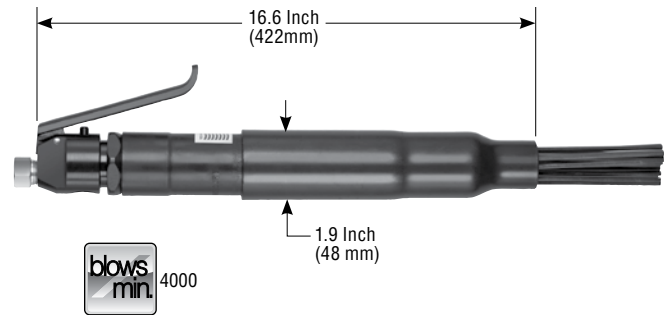
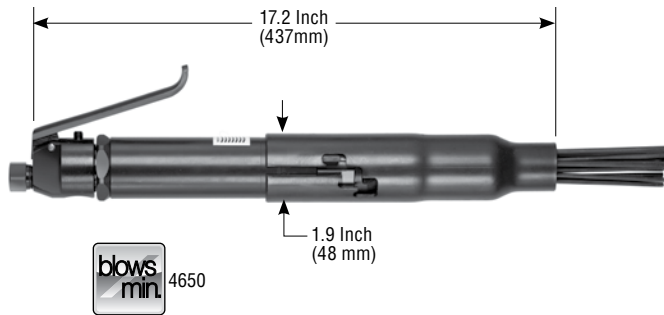

Chisels – 1/2 Inch Square Shank

Description	Cutting Edge	Overall Length	Part Number
Narrow Flat Chisel	3/4" (19mm)	7" (178mm)	839051
Narrow Flat Chisel	3/4" (19mm)	12" (305mm)	839341
Narrow Flat Chisel	3/4" (19mm)	18" (457mm)	839335
Wide Angle Chisel	1 3/8" (34.9mm)	7" (178mm)	839050
Wide Angle Chisel	1 3/8" (34.9mm)	12" (305mm)	839299
Wide Angle Chisel	1 3/8" (34.9mm)	18" (457mm)	839334
Blank Chisel		7" (178mm)	839052
Blank Chisel		12" (305mm)	839053
Blank Chisel		18" (457mm)	839054
Wide Chisel	1 3/8" (34.9mm)	7" (178mm)	839467
Wide Chisel	1 3/8" (34.9mm)	12" (305mm)	839469
2 Inch Wide Scraper	2" (50.8mm)	7" (178mm)	839468

Other Sizes And Styles Available

Chisels – 1/4 Inch Octagon

Description	Cutting Edge	Overall Length	Part Number
Narrow Flat Chisel	3/4" (19mm)	7" (17.8cm)	839601
Narrow Flat Chisel	3/4" (19mm)	12" (30.5cm)	839601-12
Blank Chisel		7" (17.8cm)	839605
Blank Chisel		12" (30.5cm)	839605-12
Wide Chisel	1 3/8" (34.9mm)	7" (17.8cm)	839602
Wide Angle Chisel	1 3/8" (34.9mm)	7" (17.8cm)	839604
Wide Angle Chisel	1 3/8" (34.9mm)	12" (30.5cm)	839604-12

Other Sizes And Styles Available

Chipping Hammers

80 Series

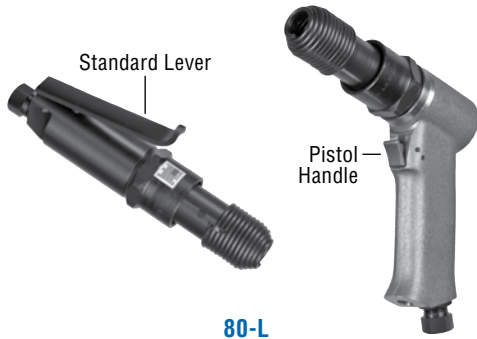

80-L

TC-183 Series



TC-183-L

Handle Type	Handle Type	MODEL NUMBER	Handle Type	Handle Type	MODEL NUMBER
0.371 Hex Shank 	Lever	80L;HEX	0.580 Hex Shank 	Lever	TC-183-L;HEX
	Safety Lever	80K;HEX		Safety Lever	TC-183-K;HEX
	Pistol	80W;HEX		Push	TC-183-P;HEX
0.401 Round Shank 	Lever	80L;RND		Pistol	TC-183-W;HEX
	Safety Lever	80K;RND		Lever	TC-183-L;RND
	Pistol	80W;RND		Safety Lever	TC-183-K;RND
			Push	TC-183-P;RND	
			Pistol	TC-183-W;RND	

bore stroke 0.6 Inch X 1.4 Inch (15mm X 36mm)

Lbs 2.8 Lbs. (1.3 Kg)

cfm 15 cfm (7.1 L/s)

SUPPLY 1/4" NPT Inlet
3/8" (10 mm) Hose Size

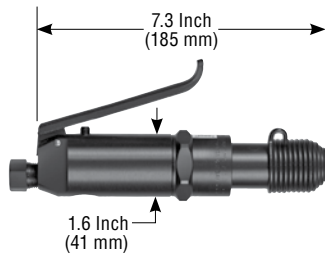

bore stroke 0.9 Inch X 3.0 Inch (23mm X 76mm)

Lbs 5.5 Lbs. (2.5 Kg)

cfm 25 cfm (11.8 L/s) Max

SUPPLY 1/4" NPT Inlet
3/8" (10 mm) Hose Size



Handle Types



Chisels – 0.401 Round

Description	Cutting Edge	Overall Length	Part Number
Flat Chisel	1/2" (12.7mm)	7" (178mm)	595002
Blank Chisel		7" (178mm)	595005

Other Sizes And Styles Available

Chisels – 0.371 Hexagon

Description	Cutting Edge	Overall Length	Part Number
Flat Chisel	1/2" (12.7mm)	12" (305mm)	595016

Other Sizes And Styles Available

Chisels – 0.580 Hexagon

Description	Cutting Edge	Overall Length	Part Number
Flat Chisel	1" (25.4mm)	9" (229cm)	839008
Flat Chisel	1" (25.4mm)	12" (30.5cm)	839009
Flat Chisel	1" (25.4mm)	18" (457cm)	839010
Moil Point		9" (229cm)	839018
Wide Flat	2" (50.8mm)	12" (30.5cm)	839016

Other Sizes And Styles Available

Chisels – 0.680 Round

Description	Cutting Edge	Overall Length	Part Number
Flat Chisel	1" (25.4mm)	9" (229cm)	839014
Flat Chisel	1" (25.4mm)	12" (30.5cm)	839083
Flat Chisel	1" (25.4mm)	18" (457cm)	839045
Moil Point		9" (229cm)	839023
Wide Flat	1.5" (38.1mm)	9" (229cm)	839019
Wide Flat	2" (50.8mm)	9" (229cm)	839017

Other Sizes And Styles Available

Motors

Top Cat Air Motors

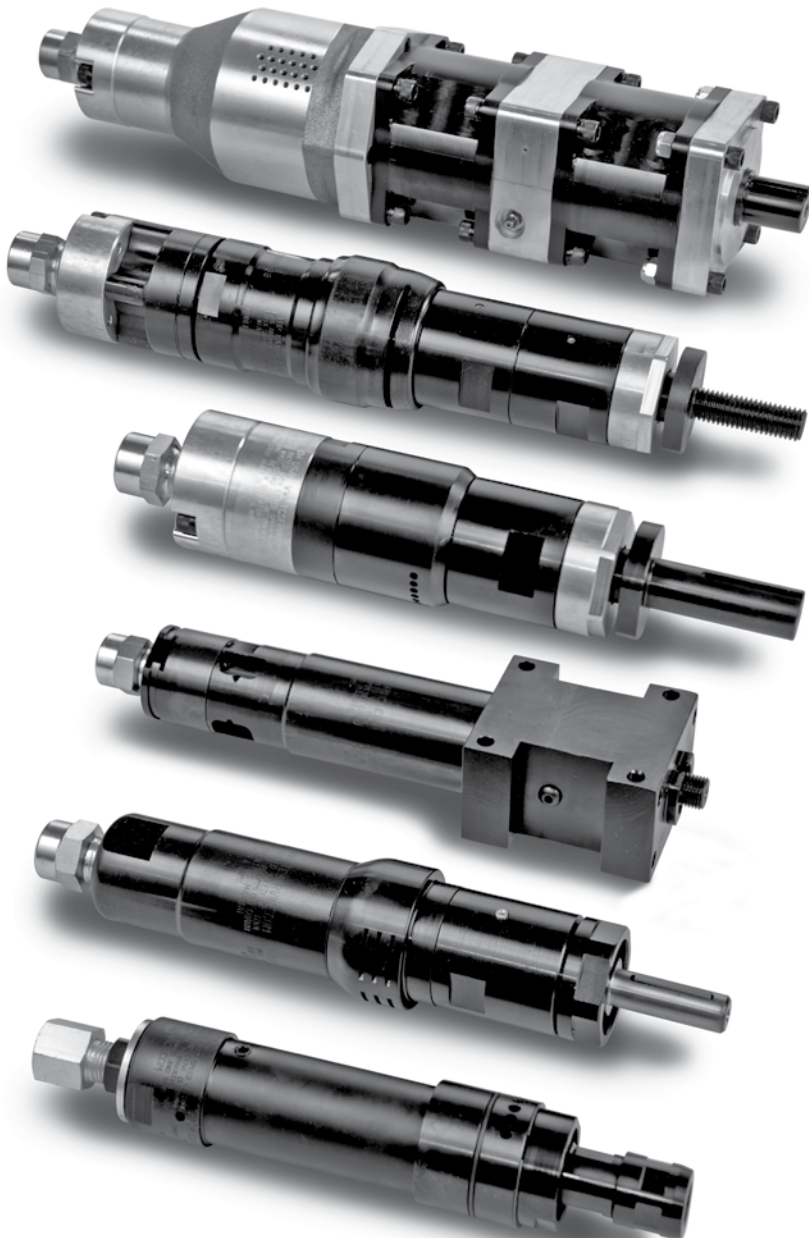

79

300 SERIES MOTORS

- 0.7 H.P.
- 150-30000 Speed Range



80

400 SERIES MOTORS

- 1.2 H.P.
- 120-20000 Speed Range



81

500 & 520 SERIES MOTORS

- 1.5 and 2.0 H.P.
- 125-4000 Speed Range



82

664 SERIES MOTORS

- 4.0 H.P.
- 85-850 Speed Range

MOTORS

Motors

0.7 H.P. Motors

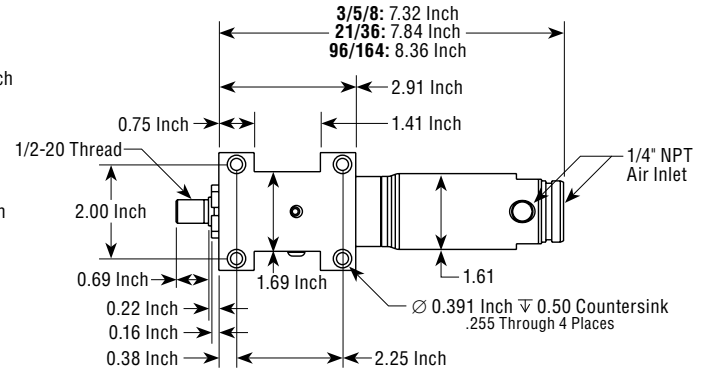
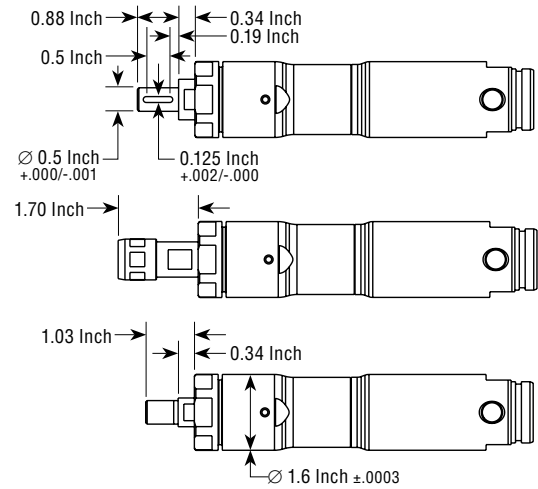

Output	Gear Ratio	RPM		Stall Torque		Weight	Round Housing	Flange and Base Mounting
		at Max H.P.	Free Speed	ft. lbs.	Nm		MODEL NUMBER	MODEL NUMBER
1/2 Inch Keyed	3:1	4125	8250	2.6	3.5	2.50 Lbs. (1.13 Kg)	300H3MSFT;8250;K500	300H3MSBRFT;8250;K500
	5:1	3000	6000	3.5	4.8		300H5MSFT;6000;K500	300H5MSBRFT;6000;K500
	8:1	1875	3750	5.8	7.9		300H8MSFT;3750;K500	300H8MSBRFT;3750;K500
	21:1	650	1300	16.0	21.8	5.00 Lbs. (2.27 Kg)	300H21MSFT;1300;K500	300H21MSBRFT;1300;K500
	36:1	400	800	26.7	36.3		300H36MSFT;800;K500	300H36MSBRFT;800;K500
	98:1	150	300	73.7	99.8		300H98MSFT;300;K500	300H98MSBRFT;300;K500
1/2 X 20 Threaded	164:1	75	150	123.2	167.0	7.50 Lbs. (3.39 Kg)	300H164MSFT;150;K500	300H164MSBRFT;150;K500
	3:1	4125	8250	2.6	3.5	2.46 Lbs. (1.11 Kg)	300H3MSFT;8250;T520	300H3MSBRFT;8250;T520
	5:1	3000	6000	3.5	4.8		300H5MSFT;6000;T520	300H5MSBRFT;6000;T520
	8:1	1875	3750	5.8	7.9		300H8MSFT;3750;T520	300H8MSBRFT;3750;T520
	21:1	650	1300	16.0	21.8	4.76 Lbs. (2.16 Kg)	300H21MSFT;1300;T520	300H21MSBRFT;1300;T520
	36:1	400	800	26.7	36.3		300H36MSFT;800;T520	300H36MSBRFT;800;T520
98:1	150	300	73.7	99.8	300H98MSFT;300;T520		300H98MSBRFT;300;T520	
Collet	164:1	75	150	123.2	167.0	6.69 Lbs. (3.03 Kg)	300H164MSFT;150;T520	300H164MSBRFT;150;T520
	1:1	15000	30000	0.8	1.1	1.80 Lbs. (0.82 Kg)	300HGSEFT;30000;1/4	
	1:1	12500	25000	0.8	1.1		300HGSEFT;25000;1/4	
	1:1	9000	18000	0.8	1.1	2.55 Lbs. (1.16 Kg)	307HGSEFT;18000;1/4	
	3:1	4125	8250	2.6	3.5	2.57 Lbs. (1.16 Kg)	300HGE3MSFT;8250;1/4	300HGE3MSBRFT;8250;1/4
	5:1	3000	6000	3.5	4.8		300HGE5MSFT;6000;1/4	300HGE5MSBRFT;6000;1/4
	8:1	1875	3750	5.8	7.9		300HGE8MSFT;3750;1/4	300HGE8MSBRFT;3750;1/4
	21:1	650	1300	16.0	21.8	4.87 Lbs. (2.21 Kg)	300HGE21MSFT;1300;1/4	300HGE21MSBRFT;1300;1/4
	36:1	400	800	26.7	36.3		300HGE36MSFT;800;1/4	300HGE36MSBRFT;800;1/4
	98:1	150	300	73.7	99.8		300HGE98MSFT;300;1/4	300HGE98MSBRFT;300;1/4
164:1	75	150	123.2	167.0	7.17 Lbs. (3.24 Kg)	300HGE164MSFT;150;1/4	300HGE164MSBRFT;150;1/4	

Note: The Flange & Base Mounting option adds 1.22 Lbs. (0.55 Kg) to weight

Motors

1.2 H.P. Motors

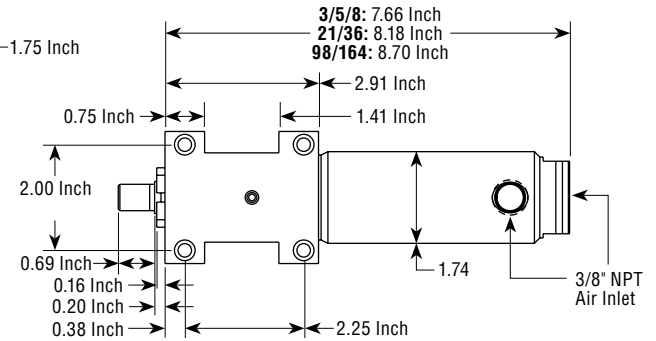
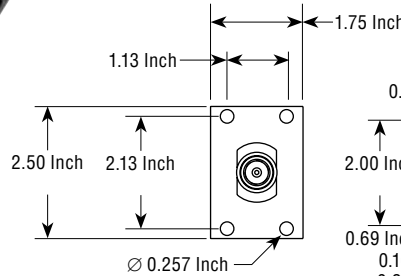
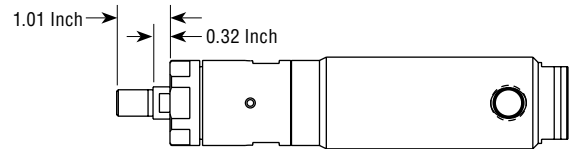
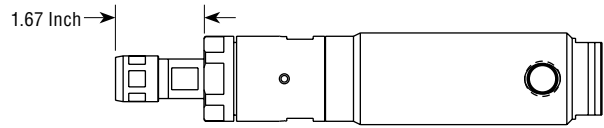
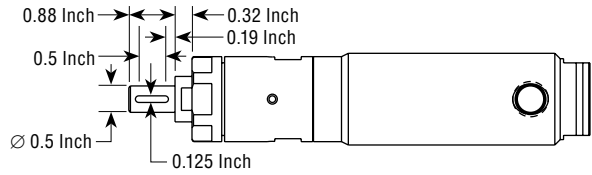

Output	Gear Ratio	RPM		Stall Torque		Weight	Round Housing	Flange and Base Mounting
		at Max H.P.	Free Speed	ft. lbs.	Nm		MODEL NUMBER	MODEL NUMBER
1/2 Inch Keyed	3:1	2250	5500	4.6	6.3	3.23 Lbs. (1.46 Kg)	400H3MSFT;5500;K500	400H3MSBRFT;5500;K500
	5:1	2000	4000	6.2	8.4		400H5MSFT;4000;K500	400H5MSBRFT;4000;K500
	8:1	1250	2500	10.3	14.0		400H8MSFT;2500;K500	400H8MSBRFT;2500;K500
	21:1	450	900	28.4	38.6	5.53 Lbs. (2.51 Kg)	400H21MSFT;900;K500	400H21MSBRFT;900;K500
	36:1	275	550	47.5	64.6		400H36MSFT;550;K500	400H36MSBRFT;550;K500
	98:1	100	200	131.1	177.7		400H98MSFT;200;K500	400H98MSBRFT;200;K500
	164:1	60	120	219.1	297.1		400H164MSFT;120;K500	400H164MSBRFT;120;K500
1/2 X 20 Threaded	3:1	2250	5500	4.6	6.3	3.12 Lbs. (1.41 Kg)	400H3MSFT;5500;T520	400H3MSBRFT;5500;T520
	5:1	2000	4000	6.2	8.4		400H5MSFT;4000;T520	400H5MSBRFT;4000;T520
	8:1	1250	2500	10.3	14.0		400H8MSFT;2500;T520	400H8MSBRFT;2500;T520
	21:1	450	900	28.4	38.6	5.37 Lbs. (2.43 Kg)	400H21MSFT;900;T520	400H21MSBRFT;900;T520
	36:1	275	550	47.5	64.6		400H36MSFT;550;T520	400H36MSBRFT;550;T520
	98:1	100	200	131.1	177.7		400H98MSFT;200;T520	400H98MSBRFT;200;T520
	164:1	60	120	219.1	297.1		400H164MSFT;120;T520	400H164MSBRFT;120;T520
Collet	1:1	10000	20000	1.3	1.8	2.53 Lbs. (1.15 Kg)	400HGESFT;20000;1/4	
	1:1	9000	18000	1.3	1.8		400HGESFT;18000;1/4	
	1:1	7500	15000	1.3	1.8	2.67 Lbs. (1.21 Kg)	407HGESFT;15000;1/4	
	1:1	6000	12000	1.3	1.8		407HGESFT;12000;1/4	
	3:1	2250	5500	4.6	6.3	3.30 Lbs. (1.49 Kg)	400HGE3MSFT;5500;1/4	400HGE3MSBRFT;5500;1/4
	5:1	2000	4000	6.2	8.4		400HGE5MSFT;4000;1/4	400HGE5MSBRFT;4000;1/4
	8:1	1250	2500	10.3	14.0		400HGE8MSFT;2500;1/4	400HGE8MSBRFT;2500;1/4
	21:1	450	900	28.4	38.6	5.55 Lbs. (2.51 Kg)	400HGE21MSFT;900;1/4	400HGE21MSBRFT;900;1/4
	36:1	275	550	47.5	64.6		400HGE36MSFT;550;1/4	400HGE36MSBRFT;550;1/4
	98:1	100	200	131.1	177.7		400HGE98MSFT;200;1/4	400HGE98MSBRFT;200;1/4
	164:1	60	120	219.1	297.1		400HGE164MSFT;120;1/4	400HGE164MSBRFT;120;1/4

Note: The Flange & Base Mounting option adds 1.22 Lbs. (0.55 Kg) to weight

Motors

500 Series Motors



500H1MFT;K750



500H1MFT;T625



500H2MFT;T625

Output	Gear Ratio	RPM		Stall Torque		Weight	MODEL NUMBER
		at Max H.P.	Free Speed	ft. lbs.	Nm		
3/4 Inch Keyed	4:1	2000	4000	7.3	9.9	6.58 Lbs. (2.98 Kg)	500H1MFT;4000;K750
	16:1	500	1000	29.3	39.8	8.18 Lbs. (3.71 Kg)	500H2MFT;1000;K750
	64:1	125	250	117.3	159.9	9.78 Lbs. (4.43 Kg)	500H3MFT;250;K750
5/8 X 11 Threaded	4:1	2000	4000	7.3	9.9	6.15 Lbs. (2.79 Kg)	500H1MFT;4000;T625
	18:1	500	1000	29.3	39.8	7.75 Lbs. (3.51 Kg)	500H2MFT;1000;T625
	64:1	125	250	117.3	159.9	9.35 Lbs. (4.24 Kg)	500H3MFT;250;T625

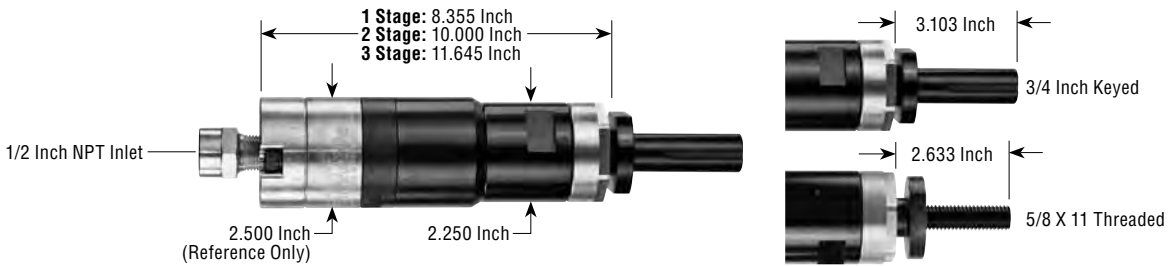

520 Series Motors



520H1MFT ;K750



520H2MFT;T625

Output	Gear Ratio	RPM		Stall Torque		Weight	MODEL NUMBER
		at Max H.P.	Free Speed	ft. lbs.	Nm		
3/4 Inch Keyed	4:1	1500	3000	14.7	20.0	8.47 Lbs. (3.84 Kg)	520H1MFT;3000;K750
	16:1	375	750	58.7	79.8	10.07 Lbs. (4.56 Kg)	520H2MFT;750;K750
	64:1	90	180	234.7	319.2	11.67 Lbs. (5.29 Kg)	500H3MFT;180;K750
5/8 X 11 Threaded	4:1	1500	3000	14.7	20.0	8.04 Lbs. (3.64 Kg)	520H1MFT;3000;T625
	16:1	375	750	58.7	79.8	9.64 Lbs. (4.37 Kg)	520H2MFT;750;T625
	64:1	90	180	234.7	319.2	11.24 Lbs. (5.09 Kg)	500H3MFT;180;T625

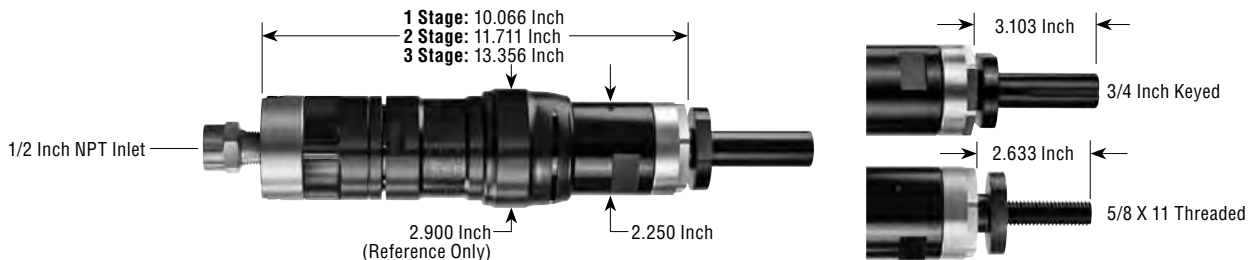

Motors

664 Series Motors



664H1MFT



664H2MFT;T625

Output	Gear Ratio	RPM		Stall Torque		Weight	MODEL NUMBER
		at Max H.P.	Free Speed	ft. lbs.	Nm		
3/4 Inch Keyed	10:1	425	850	73.2	99.2	15.08 Lbs. (6.83 Kg)	664H1MFT;850;K1
	100:1	42	85	720.3	976.6	22.89 Lbs. (10.37 Kg)	664H2MFT;85;K1

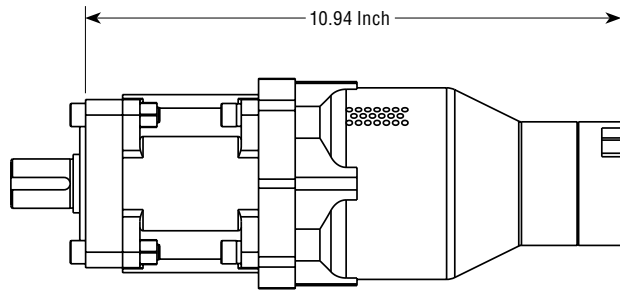

664H1MFT

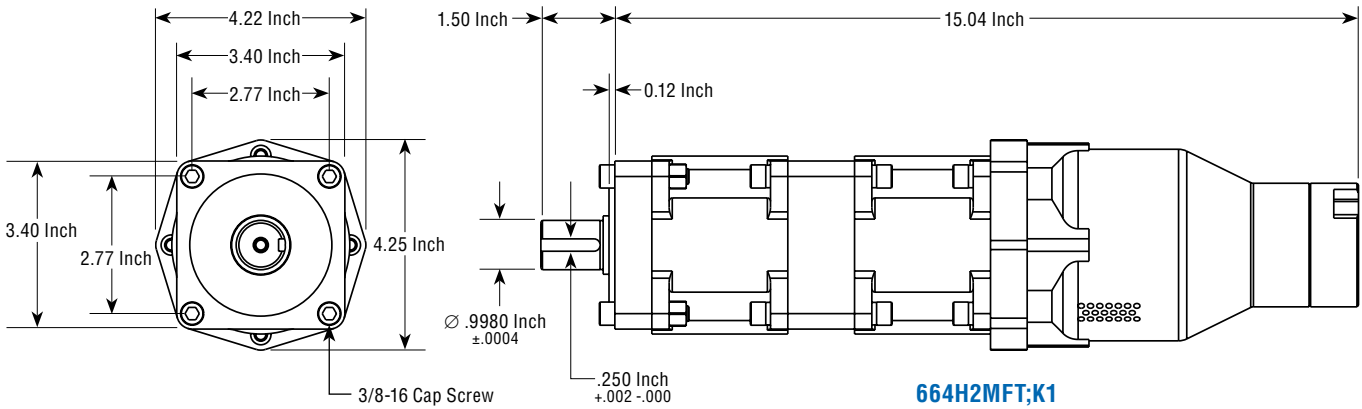

664H2MFT;K1

MOTORS

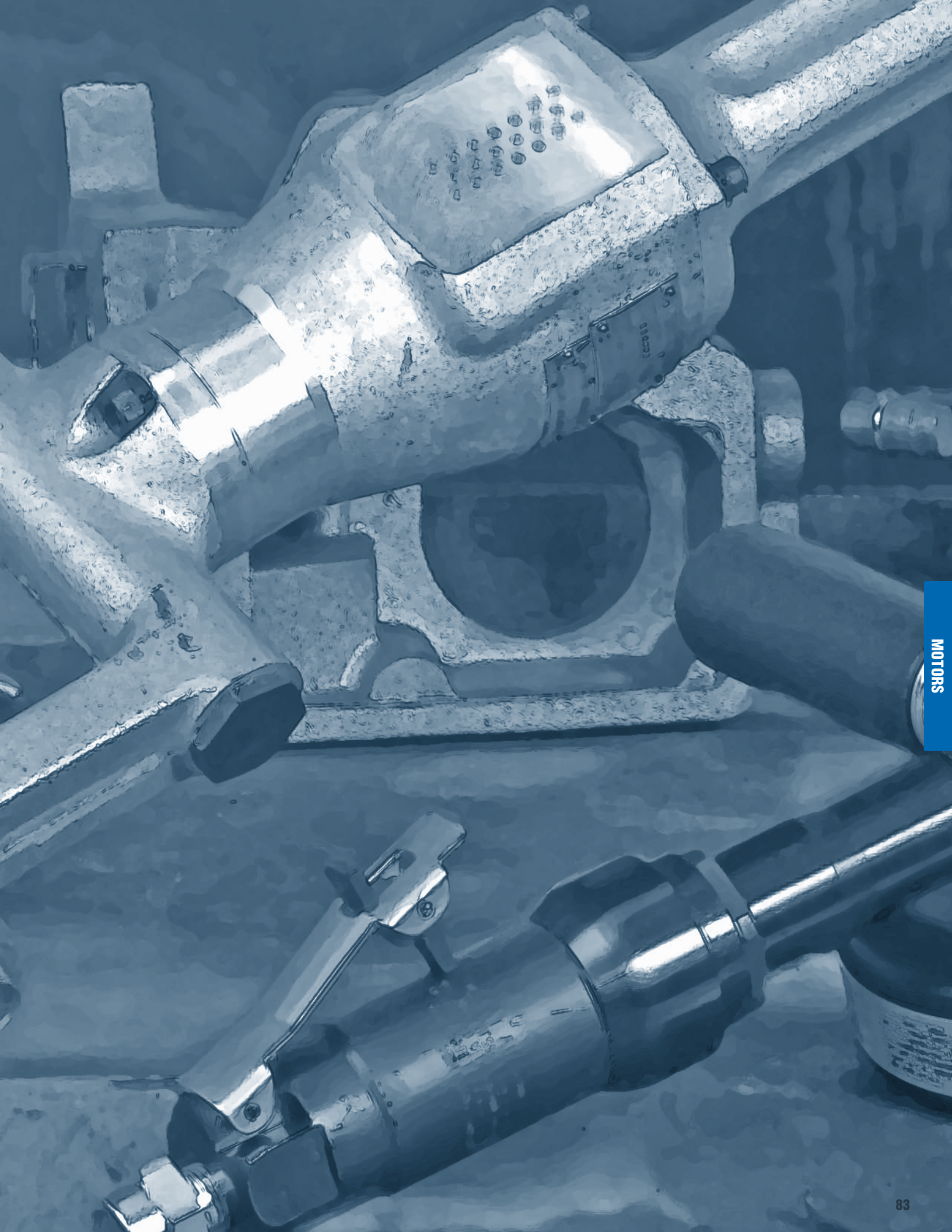

Sanding Pads



SANDING PADS FOR VERTICAL SANDERS

Model	Size	Part Number	Max. Rated Speed
520V	7 Inch	849913	8500 RPM
	9 Inch	849914	6500 RPM
56S	7 Inch	849913	8500 RPM
	9 Inch	849914	6500 RPM

5/8-11 Nut	849259
Pin Wrench	102-SPWR

SANDING PADS FOR RIGHT ANGLE SANDERS

Model	Spindle Output	Size	Part Number	Max. Rated Speed
300RA(E)(X)M	5/8-11 Output Spindle	5 Inch	849848	10000 RPM
400RA(E) & 407RA(E)	3/8-24 Output Spindle	4 Inch	889271-A	12000 RPM
		5 Inch	849848-A	10000 RPM
	5/8-11 Output Spindle	4 Inch	889271	12000 RPM
		5 Inch	849848	10000 RPM
400RA(E)(X)M	5/8-11 Output Spindle	7 Inch	849913	8500 RPM
4520RA & 4620RA	5/8-11 Output Spindle	7 Inch	849913	8500 RPM
4620RA(X)M	5/8-11 Output Spindle	7 Inch	849913	8500 RPM
520RA	5/8-11 Output Spindle	7 Inch	849913	8500 RPM

3/8-24 Nut	849259-A
5/8-11 Nut	849259
Pin Wrench	102-SPWR

Other Accessories

SCREEN HANDLE BUSHINGS

Description	Part Number
1/4" NPT Male to 1/4" NPT Female	400-27
3/8" NPT Male to 3/8" NPT Female	841552
3/8" NPT Male to 1/4" NPT Female	841553
1/2" NPT Male to 1/2" NPT Female	841555

COLLETS

Type	Description	Part Number
2 Pc. Collets (Split Style Collets)	3/8-24 Type 1 Spindle to 1/4" Collet	TC-1010
	3/8-24 Type 1 Spindle to 3/8" Collet	TC-1010-3/8
	3/8-24 Cone Spindle to 1/4" Collet	TC-1012A
	5/8-11 Cone Spindle to 1/4" Collet	TC-1104
3 Pc. Collet (Insert Style Collet)	3/8-24 Cone Spindle to XX Collet	AA-H209-XX

Note: The XX in the AA-H209 represents the insert size. (ex.- 1/4, 6MM,3/8, etc.)

CONE WHEEL ADAPTERS

Model	Description	Part Number
400GH4/407GH4/500H4/507H4	3/8-24 Type 1 Spindle to 3/8-24 Cone	400-77
520H 56H/65H	5/8-11 Type 1 Spindle to 5/8-11 Cone	700-4CW

Guards



GUARDS FOR VERTICAL GRINDERS

Type 27 Wheel Guards			Type 28 Wheel Guards		
Model	Size	Part Number	Model	Size	Part Number
520V	7 Inch	NV-G-727	520V	7 Inch	NV-G-728
	9 Inch	NV-G-927		9 Inch	NV-G-928
54V	7 Inch	700-200	54V	7 Inch	700-200-28
	9 Inch	700-201		9 Inch	700-201-28
64V	7 Inch	700-200	64V	7 Inch	700-200-28
	9 Inch	700-201		9 Inch	700-201-28

GUARDS FOR RIGHT ANGLE GRINDERS

Depressed Center Wheel (Type 27) Guards			Type 1 Cut-Off Wheel (Type 41) Guards		
Model	Size	Part Number	Model	Size	Part Number
300RA	4 Inch	HRGD-427	300RA	4 Inch	HRGD-441
	4 1/2 Inch	HRGD-4527		4 1/2 Inch	HRGD-4541
300RAE	4 Inch	HRGD-427	300RAE	4 Inch	HRGD-441
	4 1/2 Inch	HRGD-4527		4 1/2 Inch	HRGD-4541
400RA	4 Inch	HRGD-427	400RA	4 Inch	HRGD-441
	4 1/2 Inch	HRGD-4527		4 1/2 Inch	HRGD-4541
	5 Inch	HRGD-527		5 Inch	HRGD-541
400RAE	4 Inch	HRGD-427	400RAE	4 Inch	HRGD-441
	4 1/2 Inch	HRGD-4527		4 1/2 Inch	HRGD-4541
	5 Inch	HRGD-527		5 Inch	HRGD-541
	6 Inch	HRGD-627		6 Inch	HRGD-641
410RA	4 Inch	HRGD-427	410RA	4 Inch	HRGD-441
	4 1/2 Inch	HRGD-4527		4 1/2 Inch	HRGD-4541
410RAE	4 Inch	HRGD-427	410RAE	4 Inch	HRGD-441
	4 1/2 Inch	HRGD-4527		4 1/2 Inch	HRGD-4541
320RA	4 Inch	ERGD-427	320RA	4 Inch	ERGD-441
420RA		NRA-727	420RA		NRA-1041
520RA	7 Inch	NRA-727	520RA	10 Inch	NRA-1041
	9 Inch	NRA-927			

CUP WHEEL GUARDS

Type 11 Wheel Guards		
Model	Size	Part Number
520V	4 Inch	NV-G-411
58C	4 Inch	560-46
	5 Inch	560-45
	6 Inch	412988
68C	5 Inch	560-45
	6 Inch	412988

GUARDS FOR HORIZONTAL GRINDERS

Type 1 Wheels Guards		
Model	Size	Part Number
400GH4	3 Inch	HG3-01
407GH4	4 Inch	HG4-01
500H4	3 Inch	HG3-01
507H4	4 Inch	HG4-01
520H	4 Inch	5204-01
	6 Inch	5206-01
56H	6 Inch	650-HS-56A
	8 Inch	650-HS-58A
65H	6 Inch	650-HS-56A
	8 Inch	650-HS-58A

GUARDS FOR EXTENDED GRINDERS

Type 1 Wheels Guards		
Model	Size	Part Number
400GEH4	3 Inch	HG3-01
407GEH4	4 Inch	HG4-01
520HGEH	4 Inch	5204-01
	6 Inch	5206-01
65HGEH	6 Inch	5206-01

GUARDS FOR DIE GRINDERS

Type 1 Wheels Guards		
Model	Size	Part Number
400GT4	3 Inch	4503-01
407GT4	4 Inch	4504-01

Maintenance Tools

MAINTENANCE TOOLS Bearing Drivers/Spindle Holders

Vertical Grinders

Model	Description	Bearing	Part Number
54V/58C/64V/68C	Bearing Driver	700-7 (Front)	1100-834
	Bearing Driver	700-9 (Rear)	1100-808
	Spindle Holder		1100-650

Right Angle Grinders/Sanders

Model	Description	Bearing	Part Number
300RA(E)	Bearing Driver	400-9	1100-802
320RA	Bearing Driver	400-9	1100-802
330RA / 340RA	Bearing Driver	400-9	1100-802
3101RA	Bearing Driver	400-9	1100-802
400RA(E)/410RA(E)	Bearing Driver	H9	1100-802
420RA	Bearing Driver	H9	1100-802
4101RA	Bearing Driver	H9	1100-802
4520RA/4620RA	Bearing Driver	H9	1100-802

Horizontal Grinders

Model	Description	Bearing	Part Number
300EH	Bearing Driver	400-9	1100-802
300GH	Bearing Driver	400-9	1100-802
	Coupling Nut Holder		1100-862
400GH	Bearing Driver	H9	1100-802
	Coupling Nut Holder		1100-862
56H/65H	Bearing Driver	550-10H (Middle)	1100-822
	Bearing Driver	700-9 (Rear)	1100-808
	Spindle Holder		1100-650

MAINTENANCE TOOLS Bearing Drivers/Spindle Holders

Extended Grinders

Model	Description	Bearing	Part Number
400EH/400GEH	Bearing Driver	H9	1100-802
	Coupling Nut Holder		1100-862
520HGEH	Coupling Nut Holder		1100-862
65HGEH	Bearing Driver	700-9 (Rear)	1100-808
	Spindle Holder		1100-650
	Coupling Nut Holder		1100-862

Die Grinders

Model	Description	Bearing	Part Number
300GE/300HGE	Bearing Driver	400-9	1100-802
400GE/400HGE/400GT	Bearing Driver	H9	1100-802

MAINTENANCE TOOLS Depressed Center Wheel Adapters

Vertical Grinders

Model	Wheel Size	Description	Part Number
54V/64V/520V	7 Inch or 9 Inch	Depressed Center Wheel Adapter	849269

Right Angle Grinders

Model	Wheel Size	Description	Part Number
300RA(E)/400RA(E)/410RA(E)	4"	3/8-24 (Long Spindle) to 3/8 ID Adapter Set	490-K
		3/8-24 (Long Spindle) to 5/8 ID Adapter Set	AA-ADT27-354
320RA/420RA		3/8-24 (Short Spindle) to 3/8 ID Adapter Set	490-KR
300RA(E)/400RA(E)/410RA(E)	4 1/2"	3/8-24 (Long Spindle) to 7/8 ID Adapter Set	AA-ADT27-375
400RA(E)	5"	5/8-11 to 7/8 ID Adapter Set	AA-ADT27-575
400RAE	6"		
520RA	7 Inch or 9 Inch	Depressed Center Wheel Adapter	849269

Repair Kits

Vertical Grinders/Sanders

Model	Description	Part Number
520V	Repair Kit	510254
54V/56S/58C	Repair Kit	510077
64V/68C	Repair Kit	510088
727V/711C	Repair Kit	510488

Horizontal Grinders/Sanders

Model	Description	Part Number
300EH	Repair Kit	510310
300GHD	Repair Kit	510314
300GH3M	Repair Kit	510314
	Gear Train Kit	510344
300GH5M / 300GH8M	Repair Kit	510314
	Gear Train Kit	510346
400GH/407GH	Repair Kit	510286
400GH3M	Repair Kit	510286
	Gear Train Kit	510344
400GH5M / 400GH8M	Repair Kit	510286
	Gear Train Kit	510346
500H1M	Repair Kit	510490
507H	Repair Kit	510492
520H	Repair Kit	510494
56H	Repair Kit	510081
65H	Repair Kit	510082

Extended Grinders

Model	Description	Part Number
400EH	Repair Kit	510250
400GEH	Repair Kit	510252
520HGEH	Repair Kit	510280
65HGEH	Repair Kit	510306
65NEH	Repair Kit	510496

Right Angle Grinders/Sanders

Model	Description	Part Number
300RA	Motor Repair Kit	510312
	Head Repair Kit	510318
300RAE	Motor Repair Kit	510312
	Head Repair Kit	510320
300RA3M	Motor Repair Kit	510312
	Gear Train Kit	510344
	Head Repair Kit	510318
300RA5M / 300RA8M	Motor Repair Kit	510312
	Gear Train Kit	510346
	Head Repair Kit	510318
300RAE3M	Motor Repair Kit	510312
	Gear Train Kit	510344
	Head Repair Kit	510320
300RAE5M / 300RAE8M	Motor Repair Kit	510312
	Gear Train Kit	510346
	Head Repair Kit	510320
300VGE	Repair Kit	510312
320RA (Threaded Output)	Motor Repair Kit	510312
	Head Repair Kit	510330
320RA (Collet Output)	Motor Repair Kit	510312
	Head Repair Kit	510332
330RA/340RA (Threaded Output)	Motor Repair Kit	510312
	Head Repair Kit	510336
330RAD/340RAD (Collet Output)	Motor Repair Kit	510312
	Head Repair Kit	510334
400RA/407RA/410RA	Motor Repair Kit	510284
	Head Repair Kit	510318
400RAE/407RAE/410RAE	Motor Repair Kit	510284
	Head Repair Kit	510338
400RA3M	Motor Repair Kit	510284
	Gear Train Kit	510344
	Head Repair Kit	510318
400RA5M/ 400RA8M	Motor Repair Kit	510284
	Gear Train Kit	510346
	Head Repair Kit	510318
400RAE3M	Motor Repair Kit	510284
	Gear Train Kit	510344
	Head Repair Kit	510320
400RAE5M/ 400RAE8M	Motor Repair Kit	510284
	Gear Train Kit	510346
	Head Repair Kit	510320
420RA (Threaded Output)	Motor Repair Kit	510284
	Head Repair Kit	510330
420RAD (Collet Output)	Motor Repair Kit	510284
	Head Repair Kit	510332
520RA	Motor Repair Kit	510260-A
3101RA	Motor Repair Kit	510312
	Head Repair Kit	510338
4101RA	Motor Repair Kit	510284
	Head Repair Kit	510338
4520RA	Motor Repair Kit	510284
	Head Repair Kit	510308
4620RA	Motor Repair Kit	510284
	Head Repair Kit	510308
4620RA3M	Motor Repair Kit	510284
	Gear Train Kit	510344
	Head Repair Kit	510308
4620RA5M / 4620RA8M	Motor Repair Kit	510284
	Gear Train Kit	510346
	Head Repair Kit	510308

GENERAL NOTE: Right angle head repair kits do not include the angle gears.

Repair Kits

Die Grinders/Sanders		
Model	Description	Part Number
300GE/307GE	Repair Kit	510312
300HGE/307HGE	Repair Kit	510300
300HGE3M/300GT3M	Motor Repair Kit	510486
	Gear Train Kit	510344
300HGE5M/300GT5M 300HGE8M/300GT8M	Repair Kit	510486
	Gear Train Kit	510346
400GE/407GE	Repair Kit	510284
400HGE/407HGE 400GT/407GT	Repair Kit	510282
400HGE3M/400GT3M	Motor Repair Kit	510412
	Gear Train Kit	510344
400HGE5M/400GT5M 400HGE8M/400GT8M	Motor Repair Kit	510412
	Gear Train Kit	510346

Bench Grinder		
Model	Description	Part Number
66VBG	Repair Kit	510484

Belt Sander		
Model	Description	Part Number
300VBL	Repair Kit	510312

Abrasive Cut Off Tools		
Model	Description	Part Number
65VBW	Repair Kit	510088
662VBW	Repair Kit	510498

Drills		
Model	Description	Part Number
300D3M	Motor Repair Kit	510312
	Gear Train Kit	510344
300D5M / 300D8M	Motor Repair Kit	510312
	Gear Train Kit	510346
300DRA3M	Motor Repair Kit	510312
	Gear Train Kit	510344
	Head Repair Kit	510318
300DRA5M / 300DRA8M	Motor Repair Kit	510312
	Gear Train Kit	510346
	Head Repair Kit	510318
300DRAE3M	Motor Repair Kit	510312
	Gear Train Kit	510344
	Head Repair Kit	510320
300DRAE5M / 300DRAE8M	Motor Repair Kit	510312
	Gear Train Kit	510346
	Head Repair Kit	510320
400D3M	Motor Repair Kit	510284
	Gear Train Kit	510344
400D5M / 400D8M	Motor Repair Kit	510284
	Gear Train Kit	510346
400DRA3M	Motor Repair Kit	510284
	Gear Train Kit	510344
	Head Repair Kit	510318
400DRA5M / 400DRA8M	Motor Repair Kit	510284
	Gear Train Kit	510346
	Head Repair Kit	510318
400DRAE3M	Motor Repair Kit	510284
	Gear Train Kit	510344
	Head Repair Kit	510320
400DRAE5M / 400DRAE8M	Motor Repair Kit	510284
	Gear Train Kit	510346
	Head Repair Kit	510320
400FD3M	Motor Repair Kit	510284
	Gear Train Kit	510344
400FD5M / 400FD8M	Motor Repair Kit	510284
	Gear Train Kit	510346
500FD1M	Repair Kit	510490

T.C. Service Co. has a growing worldwide network of quality Authorized Agents that provide the total package...sales, service and repair.

Our joint goal is to provide you with the best American-made pneumatic tools for your application. TOP CAT® is proud to deliver quality tools at a competitive price. Our knowledgeable Authorized Agents can offer the kind of customer service you deserve.

We strive to keep our Authorized Agents aware of our continued "Low Vibration" advancements, so they can offer tool selection recommendations. Technical assistance is always available. Our Authorized Agents work with us to address any "custom" tool needs you may encounter.

For over 30 years, air tools with the TOP CAT® trademark have represented the highest quality in design, performance and durability. Thank you for choosing TOP CAT®. We appreciate your business.

Warranty

SUBJECT TO THE TERMS AND CONDITIONS HEREINAFTER SET FORTH, T.C. SERVICE CO. WARRANTS PRODUCTS AND PARTS SOLD BY IT, INsofar AS THEY ARE OF ITS OWN MANUFACTURE, AGAINST DEFECTS OF MATERIAL AND WORKMANSHIP, UNDER USE AND SERVICE IN ACCORDANCE THE T.C. SERVICE CO.'S WRITTEN INSTRUCTIONS, RECOMMENDATIONS, AND RATINGS FOR INSTALLATION, OPERATION, MAINTENANCE, AND SERVICE OF PRODUCTS, FOR A PERIOD OF ONE YEAR FROM THE DATE OF SHIPMENT BY T.C. SERVICE CO., OR ANY OF T.C. SERVICE CO.'S AUTHORIZED DISTRIBUTORS. THIS WARRANTY DOES NOT APPLY TO MISUSED, ABUSED, MODIFIED, OR TO USE ATTRIBUTED TO NORMAL WEAR OF THE TOOL.

THIS WARRANTY IS LIMITED TO THE REPAIR OR REPLACEMENT, AS T.C. SERVICE CO. MAY ELECT, OF ANY DEFECTIVE PARTS, REGARDING WHICH, UPON DISCOVERY OF THE DEFECTS, THE PURCHASER HAS GIVEN IMMEDIATE WRITTEN NOTICE. INSTALLATION AND TRANSPORTATION COSTS ARE NOT INCLUDED. T.C. SERVICE CO. SHALL HAVE THE OPTION OF REQUIRING THE RETURN TO IT OF THE DEFECTIVE MATERIAL, TRANSPORTATION PREPAID, FOR INSPECTION.

THIS WARRANTY IS IN LIEU OF ALL OTHER, EXPRESS OR IMPLIED, INCLUDING WITHOUT LIMITATION ANY WARRANTY OF MERCHANTABILITY OR FITNESS FOR ANY PURPOSE. THE FORGOING STATES THE PURCHASER'S SOLE AND EXCLUSIVE REMEDY AND T.C. SERVICE CO.'S SOLE AND EXCLUSIVE LIABILITY FOR ANY CLAIMS OF DAMAGE IN CONNECTION WITH THE SALE OF PRODUCTS OR PARTS HEREUNDER. T.C. SERVICE CO. WILL IN NO EVENT BE LIABLE FOR ANY CONSEQUENTIAL, INCIDENTAL, SPECIAL OR CONTINGENT DAMAGE OR EXPENSE ARISING DIRECTLY OR INDIRECTLY FROM ANY DEFECT IN ITS PRODUCTS OR PARTS OR FROM THE USE OF ANY DEFECTIVE PRODUCTS OR PARTS. NOR IS ANY OTHER PERSON AUTHORIZED TO ASSUME FOR T.C. SERVICE CO. ANY SUCH LIABILITY. T.C. SERVICE CO.'S LIABILITY FOR LOSSES OR DAMAGES ARISING OUT OF THE SUPPLY OR USE OF ITS PRODUCTS OR PARTS SHALL IN NO EVENT EXCEED THE PRICE CHARGED FOR SUCH PRODUCTS OR PARTS. THE GOVERNOR IS GUARANTEED FOR THE LIFE OF THE TOOL, IF NOT ABUSED.



T.C. Service Co.
38285 Pelton Road • Willoughby, Ohio 44094 U.S.A.
Phone: (440) 954-7500 • (800) 321-6876
Fax: (440) 954-7118 • (877) 800-3589
Visit our web site: www.tcservice.com
E-Mail: sales@tcservice.com

Model Listing	Description	Page
300B	Belt Sander	70
300D(X)M	Inline Drill	66
300DRA(X)M	Right Angle Drill	68
300DRAE(X)M	Extended Right Angle Drill	68
300EH	Extended Die Grinder	44
300GE	Die Grinder	58
300GH	Horizontal Grinder	44
300GH(X)M	Horizontal Sander/Polisher	46
300GT(X)M	Sander/Polisher	63
300HGE	Die Grinder	58
300HGE(X)M	Sander/Polisher	62
300RA	Right Angle Grinder	16, 22 & 30
300RA(X)M	Right Angle Sander/Polisher	36
300RAE	Extended Right Angle Grinder	17, 23 & 31
300RAE(X)M	Extended Right Angle Sander/Polisher	37
300VGE	Vertical Die Grinder	26
307GE	Die Grinder	58
307HGE	Die Grinder	58
307RA	Right Angle Grinder	30
307RAE	Right Angle Sander	31
3101RA	Right Angle Sander/Polisher	34
320RA	Right Angle Grinder	18, 25 & 33
330RA	Right Angle Die Grinder	24 & 32
340RA	Right Angle Die Grinder	24 & 32
400/410RA(X)M	Right Angle Sander/Polisher	36
400/410RAE(X)M	Extended Right Angle Sander/Polisher	37
400D(X)M	Inline Drill	66
400DRA(X)M	Right Angle Drill	68
400DRAE(X)M	Extended Right Angle Drill	68
400EH	Extended Grinder	50
400FD(X)M	Floor Drill	69
400GE	Die Grinder	59
400GEH	Extended Grinder	51
400GH	Horizontal Grinder	40, 42, 43 & 45
400GH(X)M	Horizontal Sander/Polisher	46
400GT	Die Grinder	59, 60 & 61
400GT(X)M	Sander/Polisher	63
400H(X)M	Power Supply Motor	80
400HGE	Die Grinder	59
400HGE(X)M	Sander/Polisher	62
400RA	Right Angle Grinder	16 & 30
400RAE	Right Angle Grinder	17 & 31
407GEH	Extended Grinder	51
407GH	Horizontal Grinder	40

Model Listing	Description	Page
407GT	Die Grinder	60 & 61
407RA	Right Angle Sander/Polisher	30
4101RA	Right Angle Sander/Polisher	34
410RA	Right Angle Grinder	22
410RAE	Right Angle Grinder	23
420RA	Right Angle Grinder	18, 25 & 33
4520RA	Right Angle Sander/Polisher	35
4620RA	Right Angle Sander/Polisher	35
4620RA(X)M	Right Angle Sander/Polisher	36
500D2M	Inline Drill	67
500FD1M	Floor Drill	69
500H1M	Power Supply Motor	81
500H2M	Power Supply Motor	81
500H3M	Power Supply Motor	81
507H	Horizontal Grinder	40, 42, 43 & 45
520H	Horizontal Grinder	41 & 43
520H1M	Power Supply Motor	81
520H2M	Power Supply Motor	81
520H3M	Power Supply Motor	81
520HGEH	Extended Grinder	52
520RA	Right Angle Grinder	19 & 35
520V	Vertical Grinder	7, 9 & 12
54V	Vertical Grinder	7
56H	Horizontal Grinder	41
56PC	Pile Cutter	11
56S	Vertical Sander	12
58C	Vertical Grinder	9
64V	Vertical Grinder	8
65H	Horizontal Grinder	41
65HGEH	Extended Grinder	53
65NEH	Extended Grinder	54
65VBW	Abrasive Cutting Machine	72
662VBW	Abrasive Cutting Machine	72
664	Power Supply Motor	82
66PC	Pile Cutter	11
66VBG	Bench Grinder	71
68C	Vertical Grinder	10
711C	Vertical Grinder	10
727V	Vertical Grinder	8
80-SERIES	Chipping Hammer	77
TC-1	Scaler	75, 76
TC-182	Scaler	75, 76
TC-183	Chipping Hammer	77

TOP CAT AIR TOOLS

Made in USA

**Quality tools that perform
and last, designed and built
to meet our Customer's needs.**

Top Cat air tools are designed and built at our facilities in northeast Ohio, U.S.A. We utilize the most modern design and manufacturing techniques and equipment to provide our experienced builders with the parts needed for YOUR top quality tools. Air tools that are built for hard work, long life and safe operation.

We offer our customers a solid commitment of technical support before and after the sale. We use our 50 plus years of experience to help you select the proper tool and tool set up to meet your application needs. Our customer/technical service professionals are always ready to answer questions about our tools and share knowledge that may help in your selection of Top Cat Tools.

From our facility or at yours, we offer tool seminars/demonstrations of proper and safe tool use and repair clinics. Clinics where customers learn the real value of genuine Top Cat replacement parts.

Can't find the right tool?

Have a unique application?

Check with us.

For over 50 years we have modified existing tool designs, designed/built specialty tools to meet your needs, and in each case provided quality tools that perform, offer versatility and stay in service for a long time.

The T.C. Pride

T.C. Service has a growing worldwide network of quality Authorized Agents that provide the total package, sales, service and repair.

Our joint goal is to provide you, our customers, with the best American made pneumatic tools for the required job. These tools are Top Cat quality, delivered quickly at a competitive price. Our Authorized Agents know our tools and they can offer the kind of customer service you deserve.

We strive to keep our Authorized Agents aware of our continued ergonomic advancements, so that they can make tool selection recommendations. Technical assistance is always available. Our Authorized Agents work with us to address any special tool needs you may encounter.

To order, contact your local T.C. Service, Top Cat Authorized Agent or call us for the Agent nearest you.



T.C. Service Co.
38285 Pelton Road • Willoughby, Ohio 44094 U.S.A.
Phone: (440) 954-7500 • (800) 321-6876
Fax: (440) 954-7118 • (877) 800-3589
Visit our web site: www.tcservice.com
E-Mail: sales@tcservice.com

©2013 T.C. Service Co., all rights reserved