



High Performance Lifting

COFFING[®] **HOISTS**

GENERAL
CATALOG

LIFETIME WARRANTY

The Industry's Best

Every hoist is thoroughly inspected and tested prior to shipment from the factory. Should any problem develop, return the complete hoist prepaid to your nearest Coffing Hoists Authorized Warranty Repair Station.

If inspection reveals that the problem is caused by defective workmanship or material, repairs will be made without charge and the hoist will be returned, transportation prepaid. This warranty does not apply where: **(1)** deterioration is caused by normal wear, abuse, improper or inadequate power supply, eccentric or side loading, overloading, chemical or abrasive actions, improper maintenance, or excessive heat; **(2)** problems resulted from repairs, modifications, or alterations made by persons other than factory or Coffing Authorized Warranty Repair Station personnel; **(3)** the hoist has been abused or damaged as a result of an accident; **(4)** repair parts or accessories other than those supplied by Coffing Hoists are used on the hoist. Equipment and accessories not of the seller's manufacture are warranted by the manufacturer. Except as stated herein, Coffing Hoists makes no other warranties, express or implied, including warranties of merchantability and fitness for a particular purpose.

COFFING® HOISTS

MODEL INDEX	4	
ELECTRIC CHAIN HOISTS		
EC Model		
<i>Cutaway View</i>	6	
<i>Features</i>	8	
<i>Hook & Lug Suspension Models</i>	10	
<i>Trolley Suspension Models</i>	12	
<i>Extended Duty Model</i>	14	
<i>Turnover Model</i>	15	
JLC Model		
<i>Features</i>	16	
<i>Hook & Lug Suspension Models</i>	17	
<i>Trolley Suspension Models</i>	18	
SLC Model		19
EMC & EMW Models		20
ESC Model		21
Wire Rope Models		
<i>Features & Specifications</i>	22	
<i>Cutaway View</i>	23	
MT Model Motorized Trolley		24
ACCESSORIES		25
SPECIAL APPLICATIONS		31
SPECIFYING MODEL NUMBERS		64
AIR POWERED HOISTS		
SLA Model		32
AC Model		33
CAH Small Frame Model		
<i>Features & Specifications</i>	34	
<i>Cutaway View</i>	35	
CAH Large Frame Model		
<i>Features & Specifications</i>	36	
<i>Cutaway View</i>	37	
HT Model Trolley		38
LT Model Trolley		39
AMT Model Air Motor Trolley		40
TMM-140 Air Manipulator		41
DETERMINING AIR HOIST REQUIREMENTS		42
ACCESSORIES		43
HAND CHAIN HOISTS		
LHH Model		45
CA & CB Models		46
CTH Model		47
AT Model		48
YLHA Model		49
CHAIN CONTAINERS		53
MANUAL TROLLEYS & BEAM CLAMPS		
CBT Model		50
CTA Model		51
CYA Model		52
VT-A Model		53
BC Model Beam Clamps		53
I-BEAM SPECIFICATIONS		65
RATCHET LEVER HOISTS		
RATCHET LEVER HOIST FEATURES		54
LSB-B Model		55
TB-602 & TB-603 Models		56
PA Model		57
MA & MAL Models		58
RA Model		59
G Series Model		60
Cable Models		61
A & AD Model Load Binders		62
GT Model Ratchet Lever Tool		62

COFFING HOISTS MODEL INDEX



COFFING
HOISTS



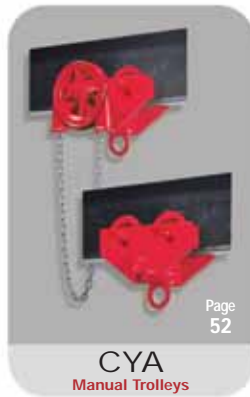



MODEL
EC

Electrical Cover —

Quick removal for easy access to motor and all electrical connections.

Hoist Motor —

High torque, H4 duty class motor with class F insulation; 60 hertz standard, 50 hertz available. Optional Variable Frequency Drives, or 2-speed motor available.

Suspension —

Easily changed from hook to lug, for use with plain, geared, or motorized trolley.

Chain Guide —

Resists jamming and keeps chain aligned with load sheave.

Internal Strain Relief —

Provides support for push button station.

Ergonomic Push Button Control —

Impact and chemical/corrosive atmosphere resistant. Our push button station fits operator's hand for thumb or two-handed operation. 24 Volt Control standard for operator safety. 115 Volt Control available upon request. NEMA 3R (weather resistant) standard.

Steel Chain —

Precision pitch, treated for optimum strength and wear resistance.

Load Blocks —

Double and triple chain models equipped with grease fitting in bottom block.

Latches —

Keeps load seated in hook. Standard on top and bottom hooks.

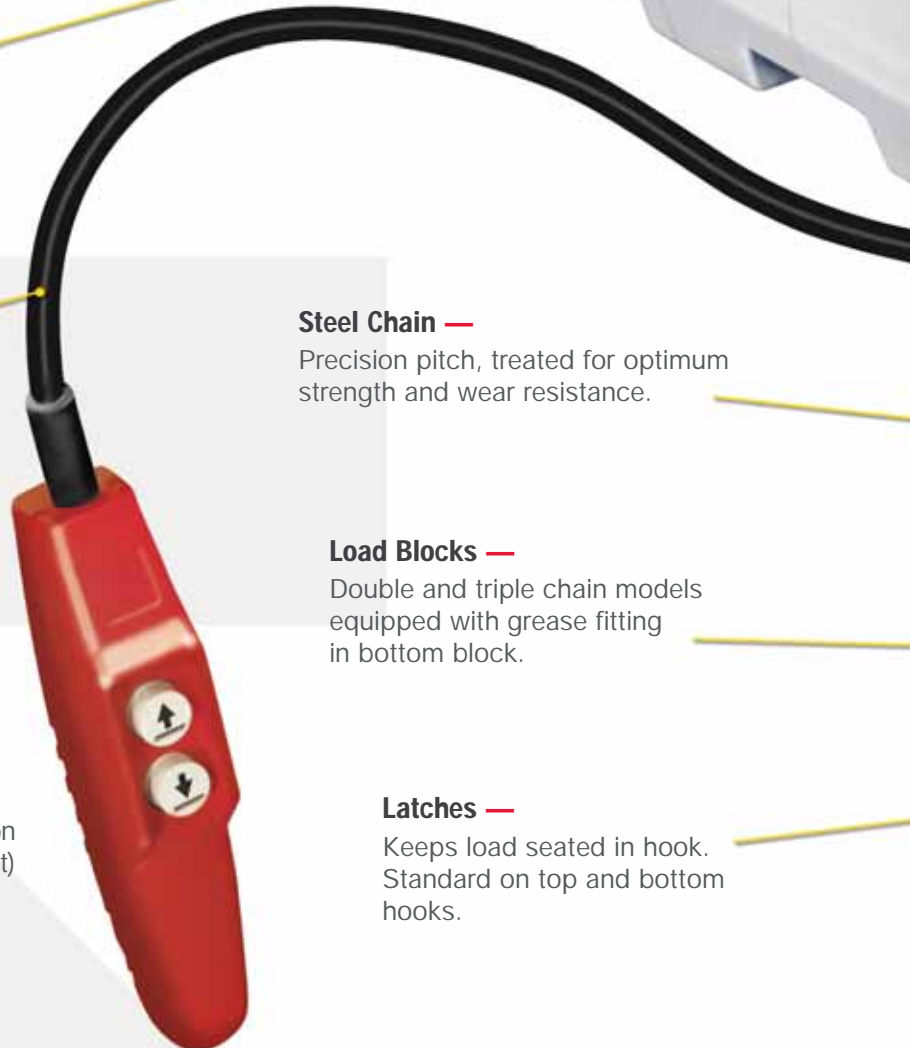

EC HOIST CUTAWAY VIEW

1/4 to 5 Ton
MODELS

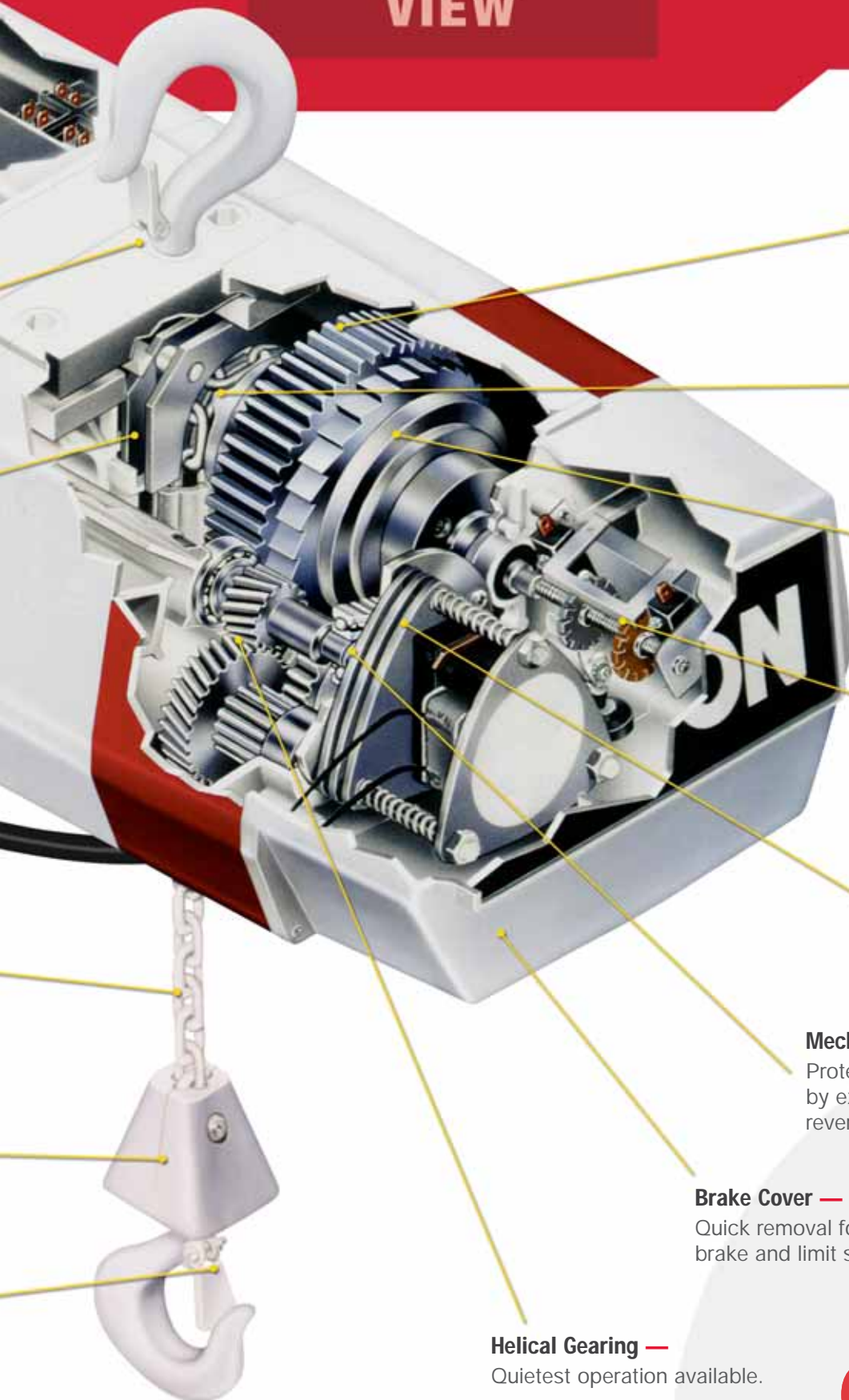

Alloy Steel Gears —

Precision machined and lubricated in oil bath for cooler, longer lasting operation.

Five-Pocket Load Sheave —

Provides improved or better chain engagement for smooth lifting and reduces chain wear.

Mechanical Load Brake —

Multiple disc type for load lowering control and additional reliability.

Limit Switches —

Adjustable upper and lower limit switches to regulate load travel.

Motor Brake —

Multiple disc, direct acting to stop load when push button is released and power off.

Mechanical Overload Device —

Protects against damage caused by excessive overloads and reverse phasing.

Brake Cover —

Quick removal for easy access to brake and limit switch.

Helical Gearing —

Quietest operation available.

COFFING[®]
HOISTS



MODEL

EC

EC HOIST FEATURES



MECHANICAL LOAD BRAKE

Weston type, controls load lowering and prevents load drift. Holds rated load independent of multiple disc motor brake.



MULTIPLE DISC MOTOR BRAKE

Heavy duty, direct acting design for positive load spotting and holding.



ERGONOMIC DESIGNED PUSH BUTTON STATION

Fits operator's hand for thumb or two-handed operation. 24 Volt Control standard for operator safety. 115 Volt Control available upon request. NEMA 3R (weather resistant). Constructed of glass-filled nylon for severe impact and chemical/corrosive atmosphere resistance.



COFFING
5-POCKET
SHEAVE

CONVENTIONAL
4-POCKET
SHEAVE



FIVE-POCKET LOAD SHEAVE

Increases chain and sheave engagement 25% over hoists with conventional four-pocket sheaves. Provides smoother lifting and reduces chain wear over four-pocket sheaves.



LIMIT SWITCHES

Adjustable to regulate upper and lower load travel. Brass nuts standard for improved switch setting and repeatability. Stainless steel limit switch shaft standard.



SOLID STATE STARTING SWITCH

Standard on single phase units. Provides greater reliability and starting consistency than centrifugal switches. Fewer components to wear out or fail.



GEARING & TRANSMISSION

First stage helical gearing on EC small frame; first and third stage helical gearing on EC large frame. Transmission gears are precision machined of alloy steel and run in oil bath for longer, quieter operation.



PANEL PLATE

Provides easy access to controls and motor leads for changing voltage on dual-voltage motors or performing hoist maintenance. Connection wires are numbered to assist maintenance.



OVERLOAD CLUTCH

Protects hoist, operator and supporting structures from damaging overloads, chain jamming, and reverse phasing.



CHAIN END STOP ASSEMBLY

Fits below dead end link on lifting chain for added measure of safety.

MODEL
ECThe **INDUSTRY
LEADER -
STRENGTH and
DEPENDABILITY****EC Hook & Lug Suspension Models****1/4 - 5 Ton****Made in USA**

COFFING EC Models - High performance hoists engineered for heavy duty industrial service. Designed for safety, the EC incorporates mechanical load brake, motor brake, and overload clutch as standard.

CAPACITIES & LIFTS - Rated loads from 1/4 to 5 Tons, with 10, 15, and 20-foot standard lifts. Other lifts available. Standard push button drop is 4-feet less than lift.

VOLTAGE & MOTOR OPTIONS - 115/230, 208 - single phase; 230/460, 208, 220/380, 575 - three phase. 60 hertz standard, 50 hertz available. Two-speed motors available (3 to 1 speed ratio).

SUSPENSION OPTIONS - Rigid or swivel top hook, lug, plain, geared, and motorized trolley available.

STANDARD FEATURES - Refer to pages 8 & 9.

SMALL FRAME DESIGN - Features housings of cast aluminum alloy construction for minimum weight. Engineered and designed for use with motors up to 1 HP.

LARGE FRAME DESIGN - Features load bearing housings of ductile iron construction for maximum strength. Non-load bearing housings of cast aluminum alloy for minimum weight. Engineered and designed for use with higher torque 2 and 3 HP three phase motors.

DURABLE CONSTRUCTION - Built in compliance with ASME/ANSI B30.16 and CSA standards.

ACCESSORIES & OPTIONS - Full line of accessories available, including Variable Frequency Drives. See pages 25-31.

LIFETIME WARRANTY

COFFING®
HOISTS

● SPECIFICATIONS ●

EC Hook & Lug Suspension Models

Capacity			Model Number	Frame *	No. of Chains	Motor HP	Lift Speed (fpm)		Headroom (in.)	Housing Dimensions (in.)			Net Wt. ** (lb.)
(lb.)	(kg) †	(Ton)					Single	Two ††		H	W	L	
500	250	1/4	EC-0516	S	1	1/4	16	5.3	16 7/8	8	11 5/8	23 3/8	100
500	250	1/4	EC-0532	S	1	1/2	32	10.7	16 7/8	8	11 5/8	23 3/8	108
500	250	1/4	EC-0564	S	1	1	64	21.3	16 7/8	8	11 5/8	23 3/8	116
1000	500	1/2	EC-1009	S	1	1/4	9	3	16 7/8	8	11 5/8	23 3/8	104
1000	500	1/2	EC-1016	S	1	1/2	16	5.3	16 7/8	8	11 5/8	23 3/8	106
1000	500	1/2	EC-1032	S	1	1	32	10.7	16 7/8	8	11 5/8	23 3/8	118
2000	1000	1	EC-2004	S	2	1/4	4	1.3	18 1/4	8	11 5/8	23 3/8	116
2000	1000	1	EC-2008	S	2	1/2	8	2.7	18 1/4	8	11 5/8	23 3/8	116
2000	1000	1	EC-2012	S	1	1	12	4	16 7/8	8	11 5/8	23 3/8	114
2000	1000	1	EC-2016	S	1	1	16	5.3	16 7/8	8	11 5/8	23 3/8	118
2000	1000	1	EC-2032	L	1	2	32	10.7	23	10 7/8	14 13/16	31 3/16	295
2000	1000	1	EC-2048	L	1	3	48	16	23	10 7/8	14 13/16	31 3/16	302
4000	2000	2	EC-4006	S	2	1	6	2	18 15/16	8	11 5/8	23 3/8	127
4000	2000	2	EC-4008	S	2	1	8	2.7	18 15/16	8	11 5/8	23 3/8	133
4000	2000	2	EC-4016	L	1	2	16	5.3	23	10 7/8	14 13/16	31 3/16	295
4000	2000	2	EC-4024	L	1	3	24	8	23	10 7/8	14 13/16	31 3/16	302
6000		3	EC-6005	S	3	1	5	1.7	23 1/4	8	12	26 3/8	200
6000	3000	3	EC-6010	L	2	2	10	3.3	27 3/8	10 7/8	14 13/16	31 3/16	340
6000	3000	3	EC-6016	L	2	3	16	5.3	27 3/8	10 7/8	14 13/16	31 3/16	347
8000		4	EC-8008	L	2	2	8	2.7	27 3/8	10 7/8	14 13/16	31 3/16	345
8000		4	EC-8012	L	2	3	12	4	27 3/8	10 7/8	14 13/16	31 3/16	352
10000	5000	5	EC-10005	L	3	2	5	1.7	27 7/8	10 7/8	14 13/16	31 3/16	393
10000	5000	5	EC-10008	L	3	3	8	2.7	27 7/8	10 7/8	14 13/16	31 3/16	393

† Metric rated option available

* S = Small frame hoist, parallel mounted, single or three phase. L = Large frame hoist, cross mounted, three phase only.

** For 10 ft. lift, top hook suspension and lug suspension units.

Note: For complete dimensional data, refer to Coffing Dimensional Databook.

HOUSING DESIGN

Brake cover (left) and electrical cover (right) easily removed for maintenance or service of unit.

(Covers for EC Small Frame Unit Shown)





MODEL
EC

SUSPENSIONS

for a **VARIETY**
of
APPLICATIONS



1/4 - 5 Ton

Made in USA

EC Trolley Suspensions

COFFING ECT, ECGT, and ECMT Models - Plain, geared and motorized trolley suspensions with all the features of basic EC models for added flexibility in a variety of applications.

PLAIN TROLLEY - For manual positioning of hoist and load.

GEARED TROLLEY - For more precise positioning of hoist and load. Standard hand chain drop is 2-feet less than lift.

MOTORIZED TROLLEY - For faster positioning of hoist and load over longer distances. 35 or 75 FPM speeds standard with optional speeds of 18, 24, 50, 100, and 150 FPM.

VOLTAGES - 115/230, 208 - single phase; 230/460, 208, 220/380, 575 - three phase. 60 hertz standard, 50 hertz available.

TWO-SPEED MOTORIZED TROLLEY MODELS - Optional with 3 to 1 speed ratio, three-phase, single voltage only.

WRAP-AROUND SIDE PLATES - Act as safety lugs and as bumpers to protect wheels. Available to fit American Standard I-Beams, wide-flange, and patented track beams. Specify track type and beam size.

PRECISION TROLLEY WHEELS - Machined, cast iron wheels with sealed, lifetime lubricated ball bearings for extended trolley life. Motorized trolley wheels heat treated for added durability. Bronze and stainless steel wheels optional.

TWO TROLLEY DESIGNS - 4-wheel design on 1/4 - 3 ton negotiates 48" minimum radius curve, including patented track applications. 8-wheel design on 4 and 5 ton reduces beam flange stress.

ACCESSORIES & OPTIONS - Full line available to meet a variety of applications. See pages 25-31.

LIFETIME WARRANTY



● SPECIFICATIONS ●

EC Plain, Geared & Motorized Suspensions

Capacity			Model Number	Frame * Size	Trolley † Mount	ECT & ECGT Hdrm (in.)	ECMT Hdrm (in.)	Flange Width (in.)	Min. Rad. Curve (in.)	Net Wt. ** (lb.)	ECMT Net Wt. (lb.)
(lb.)	(kg) ‡	(Ton)									
500	250	1/4	EC(†)-0516	S	P	17 1/4	17 1/4	3.332 - 7	48	145	180
500	250	1/4	EC(†)-0532	S	P	17 1/4	17 1/4	3.332 - 7	48	153	188
500	250	1/4	EC(†)-0564	S	P	17 1/4	17 1/4	3.332 - 7	48	161	196
1000	500	1/2	EC(†)-1009	S	P	17 1/4	17 1/4	3.332 - 7	48	151	186
1000	500	1/2	EC(†)-1016	S	P	17 1/4	17 1/4	3.332 - 7	48	151	186
1000	500	1/2	EC(†)-1032	S	P	17 1/4	17 1/4	3.332 - 7	48	163	198
2000	1000	1	EC(†)-2004	S	P	18 5/8	18 5/8	3.332 - 7	48	161	196
2000	1000	1	EC(†)-2008	S	P	18 5/8	18 5/8	3.332 - 7	48	161	196
2000	1000	1	EC(†)-2012	S	P	17 1/4	17 1/4	3.332 - 7	48	158	194
2000	1000	1	EC(†)-2016	S	P	17 1/4	17 1/4	3.332 - 7	48	163	198
2000	1000	1	EC(†)-2032	L	C	21 9/16	22 1/4	3.332 - 7	48	347	375
2000	1000	1	EC(†)-2048	L	C	21 9/16	22 1/4	3.332 - 7	48	347	375
4000	2000	2	EC(†)-4006	S	P	19 5/16	19 5/16	3.332 - 7	48	172	207
4000	2000	2	EC(†)-4008	S	P	19 5/16	19 5/16	3.332 - 7	48	178	213
4000	2000	2	EC(†)-4016	L	C	21 9/16	22 1/4	3.332 - 7	48	347	375
4000	2000	2	EC(†)-4024	L	C	21 9/16	22 1/4	3.332 - 7	48	354	362
6000		3	EC(†)-6005	S	P	23 1/4	24	3.332 - 7	48	260	320
6000	3000	3	EC(†)-6010	L	C	26	26 5/8	3.332 - 7	48	396	424
6000	3000	3	EC(†)-6016	L	C	26	26 5/8	3.332 - 7	48	403	431
8000		4	EC(†)-8008	L	C	25 15/16	26 3/4	4 - 7	***	520	560
8000		4	EC(†)-8012	L	C	25 15/16	26 3/4	4 - 7	***	527	567
10000	5000	5	EC(†)-10005	L	C	29 3/4	30 5/8	4 - 7	***	561	599
10000	5000	5	EC(†)-10008	L	C	29 3/4	30 5/8	4 - 7	***	568	606

† Specify **ECT** for plain trolley, **ECGT** for geared trolley and **ECMT** for motorized trolley models

‡ Metric rated option available

* **S** = Small frame hoist, parallel mounted, single or three phase.
L = Large frame hoist, cross mounted, three phase only.

†* **P** = Parallel mount, standard on small frame hoists.
C = Cross mount, standard on large frame hoists.

** Weight for 10 ft. lift ECT units. Add 10 lb. for ECGT unit weights.

*** 4 & 5 ton straight track only. Articulated model for 48" min. radius curved track available - consult factory.

Note: For complete dimensional data, refer to Coffing Dimensional Databook.





MODEL
ED
Extended Duty

EC HOISTS
for **SPECIAL**
APPLICATIONS



1/2 - 2 Ton

Made in USA

Extended Duty Hoists

COFFING ED Models - Extended duty service for special applications which require a hoist that exceeds the duty rating of basic EC models.

CAPACITIES & LIFTS - Rated loads from 1/4 to 2 Tons, with 10, 15, and 20-foot standard lifts. Other lifts available. Standard push button drop is 4-feet less than lift.

VOLTAGE & MOTOR OPTIONS - 230/460, three phase motors standard. Totally enclosed, fan-cooled motor keeps both motor and transmission from overheating. Consult factory for other voltage and speed options.

SUSPENSION OPTIONS - Rigid lug; plain, geared, and motorized trolleys.

DUTY CYCLE - Exceeds H4 duty service.

LOAD CHAIN - Zinc plated standard for corrosion resistance.

EXTERNAL STRAIN RELIEF - Secures to NEMA 3R push button station with extra strain relief protection.

ACCESSORIES - Full line of options to meet a variety of applications. See pages 25-31.

LIFETIME WARRANTY



● **SPECIFICATIONS** ●

ED Extended Duty Hoists

Capacity			Model * Number	No. of Chains	Motor HP	Lift Speed (fpm)	Headroom (in.)	Housing Dimensions (in.)			Net Wt. (lb.)
(lb.)	(kg) ††	(Ton)						H	W	L	
1000	500	1/2	ED(†)-1032	1	1	32	17 1/4	8 1/4	11 5/8	26 1/4	128
2000	1000	1	ED(†)-2016	1	1	16	17 1/4	8 1/4	11 5/8	26 1/4	130
4000	2000	2	ED(†)-4008	2	1	8	19 5/16	8 1/4	11 5/8	26 1/4	145

†† Metric rated option available.

* Lug, plain, geared or motorized trolley mounting

† Specify **ED** for rigid lug, **EDT** for plain trolley, **EDGT** for geared trolley and **EDMT** for motorized trolley models.

Note: For complete dimensional data, refer to Coffing Dimensional Databook

EC HOISTS for SPECIAL APPLICATIONS

MODEL
EC
Turnover Hoists



EC Turnover Model Hoists

COFFING EC Turnover Models - Specially modified EC Hoist designed for machining, assembly, or repair applications which require complete rotation and/or precise positioning of large, non-symmetrical work pieces.

CAPACITIES & LIFTS - Rated loads from 1/4 to 4 Tons. Lift stroke is 15-foot standard. Consult factory for longer lift strokes.

VOLTAGE - 230/460, three phase motors standard. Consult factory for other voltages and two speed motors.

SUSPENSION OPTIONS - Rigid lug mount only. Allows attachment to load hook of another hoist for vertical lifting.

TWO LOAD HOOKS - Color coded load hooks with corresponding push button for operator convenience.

OPERATION - Load hooks operate in opposite directions.

APPLICATION - Completely inverts virtually any shape load with use of simple slings and successive repositioning of load hooks.

ACCESSORIES - Full line of options to meet a variety of applications. See pages 25-31.

LIFETIME WARRANTY

Typical Application

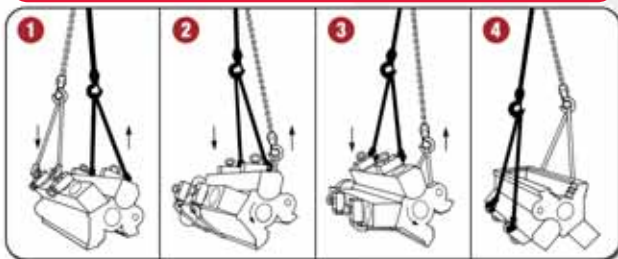

Engine block is raised straight up (1) by special cylinder lift rings, then rotated approximately 45° until one load hook (2) supports total weight. Sling is guided under block and attached to free hook (3). Hoist is then reversed (4) until block is inverted.



1/4 - 4 Ton
Made in USA

● SPECIFICATIONS ●

EC Turnover Hoists

Capacity			Model Number	Frame * Size	Load Chain Length (ft.)	Lift Stroke (ft.)	Motor HP	Lift Speed (rpm)	Headroom (in.)	Housing Dimensions (in.)			Net Wt. ** (lb.)
(lb.)	(kg) †	(Ton)								H	W	L	
500	250	1/4	EC-0516-TH	S	16	15	1/4	16	19 7/8	9 7/8	11 5/8	23 3/8	120
1000	500	1/2	EC-1016-TH	S	16	15	1/2	16	19 7/8	9 7/8	11 5/8	23 3/8	126
2000	1000	1	EC-2016-TH	S	16	15	1	16	19 7/8	9 7/8	11 5/8	23 3/8	138
4000	2000	2	EC-4016-TH	L	16	15	2	16	28 1/2	12 5/16	14 13/16	31 3/16	325
6000	3000	3	EC-6008-TH	L	34**	15	3	8	33	13 5/16	15 3/8	31 3/16	385
8000		4	EC-8008-TH	L	34**	15	3	8	33	13 5/16	15 3/8	31 3/16	390

† Metric rated option available.

* S = Small frame hoist, single or three phase. L = Large frame hoist, three phase only.

** Each load block is double-chained on 6000 lb. and 8000 lb. models.





MODEL
JLC

**JLC HOIST
FEATURES**



PANEL PLATE

Provides easy access to controls and motor leads for changing voltage on dual-voltage motors or performing hoist maintenance. Connection wires are numbered to assist maintenance.



**FIVE-POCKET
LOAD SHEAVE**

Increases chain and sheave engagement 25% over hoists with conventional four-pocket sheaves. Provides smoother lifting and reduces chain wear over four-pocket sheaves.



**MULTIPLE DISC
MOTOR BRAKE**

Heavy duty, direct acting design for positive load spotting and holding.



LIMIT SWITCHES

Adjustable to regulate upper and lower load travel. Brass nuts standard for improved switch setting and repeatability. Stainless steel limit switch shaft standard.



HOIST MOTOR

Finned aluminum housing and Class F insulation for longer life. 2-speed with 3 to 1 speed ratio available.



**MECHANICAL OVERLOAD
PROTECTION DEVICE**

Protects hoist, operator and supporting structures from damaging overloads, chain jamming, and reverse phasing.



**ERGONOMIC DESIGNED
PUSH BUTTON STATION**

Fits operator's hand for thumb or two-handed operation. 24 Volt Control standard for operator safety. 115 Volt Control available upon request. NEMA 3R (weather resistant). Severe impact and chemical/corrosive atmosphere resistant.



**CHAIN END
STOP ASSEMBLY**

Fits below dead end link on lifting chain for added measure of safety.

The **CHOICE**
for **VALUE**
and
PERFORMANCE

MODEL
JLC



JLC Hook & Lug Suspension Models

COFFING JLC Models - Designed for industrial duty performance. Compact in size, the JLC features a multiple disc motor brake, overload clutch, and chain end stop for safety.

CAPACITIES & LIFTS - Rated loads from 1/8 to 2 Tons, with 10, 15, and 20-foot standard lifts. Other lifts available. Standard push button drop is 4-feet less than lift. CSA approved.

VOLTAGES - 115/230 - single phase; 230/460, 208, 380, 415, 575 - three phase, 60 hertz standard, 50 hertz available.

TWO-SPEED HOIST MODELS - Optional with 3 to 1 speed ratio, three-phase, single voltage only.

STANDARD FEATURES - See page 16.

LIMIT SWITCHES - Adjustable to regulate upper and lower load travel. Brass nuts standard for improved repeatability and chain positioning.

OIL BATH TRANSMISSION - Precision machined alloy steel gears run in oil bath for longer, quieter operation.

NEMA 3R PUSH BUTTON STATION - Ergonomic design fits operator's hand for thumb or two-handed operation. 24 Volt Control for operator safety. 115 Volt Control available upon request.

FRAME - Compact aluminum housing for portability and ease of installation.

ACCESSORIES - Full line of accessories available, including Variable Frequency Drives. See pages 25-30.

CHAIN CONTAINER - Standard on lifts up to 20 ft. single chain / 10 ft. double chain
Chain containers available for longer lifts

LIFETIME WARRANTY



1/8 - 2 Ton
Made in USA

● SPECIFICATIONS ●

JLC Top Hook and Lug Suspension

Capacity			Model Number	No. of Chains	Motor HP	Lift Speed (fpm)		Headroom * (in.)	Housing Dimensions (in)			Net Wt. ** (lb.)
(lb.)	(kg) †	(Ton)				Single	Two		H	W	L	
250	125	1/8	JLC-0232	1	1/4	32	10.7	18 1/8	8 11/16	8 11/16	24 1/8	63
500	250	1/4	JLC-0516	1	1/2	16	5.3	18 1/8	8 11/16	8 11/16	24 1/8	63
500	250	1/4	JLC-0532	1	1/2	32	10.7	18 1/8	8 11/16	8 11/16	24 1/8	75
1000	500	1/2	JLC-1016	1	1/2	16	5.3	18 1/8	8 11/16	8 11/16	24 1/8	75
1000	500	1/2	JLC-1032	1	1	32	10.7	18 1/8	8 11/16	8 11/16	24 1/8	88
2000	1000	1	JLC-2016	1	1	16	5.3	18 1/8	8 11/16	8 11/16	24 1/8	90
4000	2000	2	JLC-4008	2	1	8	2.7	20 13/16	8 11/16	8 11/16	24 1/8	100

† Metric rated option available.

* For hook and lug mounted models only.

** Weight and dimensions for 10 ft. lift, single phase, top hook and lug suspension units.

Note: For complete dimensional data, refer to Coffing Dimensional Databook



MODEL
JLC

MOTORIZED
and **MANUAL**
TROLLEY
APPLICATIONS



1/8 - 2 Ton

Made in USA

JLC Trolley Suspensions

COFFING JLCET and JLCMT Models - Plain and motorized trolley suspensions with all the features of the basic JLC models for added flexibility in a variety of applications.

PLAIN TROLLEY - For manual positioning of hoist and load.

MOTORIZED TROLLEY - For faster positioning of hoist and load over longer distances. 35 or 75 FPM speeds standard - other speeds available. Trolley brake optional.

VOLTAGES - 115/230 - single phase; 230/460, 208, 380, 415, 575 - three phase, 60 hertz standard, 50 hertz available.

TWO-SPEED MOTORIZED TROLLEY MODELS - Optional with 3 to 1 speed ratio, three-phase, single voltage only.

WRAP-AROUND SIDE PLATES - Act as safety lugs and as bumpers to protect wheels. Available to fit American Standard I-Beams, wide-flange, and patented track beams.

PRECISION TROLLEY WHEELS - Machined, cast iron wheels with sealed, lifetime lubricated ball bearings for extended trolley life. Motorized trolley wheels are heat treated for added durability, with bronze and stainless steel wheels optional.

TROLLEY DESIGN - 4-wheel design negotiates 48" minimum radius curve, including patented track applications (60" for JLCET 2-Ton only). Specify track type and beam size.

LIFETIME WARRANTY

● **SPECIFICATIONS** ●

JLC Trolley Suspensions

Capacity			Model Number	Trolley ‡ Mount	JLCET Hdrm (in.)	JLCMT Hdrm (in.)	JLCET Flange * Width (in.)	Beam Ht. (in.)	Min. Rad. Curve (in.)	JLCET Net Wt. (lb.)	JLCMT Net Wt. (lb.)
(lb.)	(kg) ††	(Ton)									
250	125	1/8	JLC(†)-0232	C	17 15/16	17 15/16	3 - 8	5 - 12	48	87	173
500	250	1/4	JLC(†)-0516	C	17 15/16	17 15/16	3 - 8	5 - 12	48	87	173
500	250	1/4	JLC(†)-0532	C	17 15/16	17 15/16	3 - 8	5 - 12	48	99	185
1000	500	1/2	JLC(†)-1016	C	17 15/16	17 15/16	3 - 8	5 - 12	48	91	185
1000	500	1/2	JLC(†)-1032	C	17 15/16	17 15/16	3 - 8	5 - 12	48	112	198
2000	1000	1	JLC(†)-2016	C	17 15/16	17 15/16	3 - 8	5 - 12	48	114	200
4000	2000	2	JLC(†)-4008	C	20 5/8	20 5/8	3 - 8	6 - 18	60	156	210

† Specify JLCET for plain trolley and JLCMT for motorized trolley models.

†† Metric rated option available.

‡ C = Cross mount, standard on all JLC trolley models.

* For JLCMT models, standard flange adjustment is 3.33 - 6". Consult factory for special beam size options.

Note: For complete dimensional data, refer to Coffing Dimensional Databook

The PERFECT SHOP HOIST - COMPACT DESIGN, H4 DUTY CYCLE

MODEL SLC



SLC Shop Hoist

Coffing SLC Shop Hoist Models - Featuring rugged construction and high H4 duty cycle, this is the perfect hoist for around the shop or garage. This compact and job-proven hoist is ideal for commercial and industrial applications—lift up to 1000 pounds with 300 starts per hour. Put the SLC Shop Hoist to the test—it's UP for the task.

CAPACITIES & LIFT - Rated loads from 250 lb. to 1/2 Ton. 10 ft. lift standard.

VOLTAGES - 115 - single phase; 230/460, 575 - three phase, 60 hertz

SUSPENSION - Rigid top hook suspension prevents tangling of power cord.

POWER CORD - 6 1/2 ft. power cord with molded 3-prong plug on 115-volt units.

ALUMINUM HOUSING - Lightweight and compact to provide strength and portability

H4 DUTY CYCLE - 300 motor starts per hour

OVERLOAD DEVICE - Standard protector overload device protects against jamming and dangerous overloads.

LIFTWHEEL - 10-pocket oblique lay liftwheel provides longer chain wear.

GEAR TRAIN - Lifetime lubricated with non-oxidizing grease.

CHAIN - Alloy load chain (*zinc plated optional*).

H4 DUTY CYCLE - 300 motor starts per hour

ACCESSORIES & OPTIONS - Impact-resistant chain container available.

LIFETIME WARRANTY



250 - 1000 lb.

Made in USA

● SPECIFICATIONS ●

SLC Models

Capacity (lb.)	Model Number	No. of Chains	Motor HP	Lifting Speed (FPM)	Headroom (in.)	Housing Dimensions (in)			Shipping Weight (lb.)
						H	W	L	
250	SLC0216	1	1/6	16	11 1/6	4 1/16	5 15/16	12 1/2	26
250	SLC0224	1	1/6	24	11 1/6	4 1/16	5 15/16	12 1/2	28
250	SLC0240	1	1/6	40	11 1/6	4 1/16	5 15/16	12 1/2	28
300	SLC0316	1	1/6	16	11 1/6	4 1/16	5 15/16	12 1/2	28
300	SLC0324	1	1/6	24	11 1/6	4 1/16	5 15/16	12 1/2	28
300	SLC0340	1	1/6	40	11 1/6	4 1/16	5 15/16	12 1/2	28
500	SLC0508	2	1/6	8	12 1/8	4 1/16	5 15/16	12 1/2	34
500	SLC0512	1	1/6	12	11 1/6	4 1/16	5 15/16	12 1/2	28
500	SLC0516	1	1/6	16	11 1/6	4 1/16	5 15/16	12 1/2	28
500	SLC0520	2	1/6	20	12 1/8	4 1/16	5 15/16	12 1/2	34
500	SLC0524	1	1/6	24	11 1/6	4 1/16	5 15/16	12 1/2	28
600	SLC0608	2	1/6	8	12 1/8	4 1/16	5 15/16	12 1/2	34
600	SLC0612	2	1/6	12	12 1/8	4 1/16	5 15/16	12 1/2	34
600	SLC0620	2	1/6	20	12 1/8	4 1/16	5 15/16	12 1/2	34
1000	SLC1006	2	1/6	6	12 1/8	4 1/16	5 15/16	12 1/2	34
1000	SLC1008	2	1/6	8	12 1/8	4 1/16	5 15/16	12 1/2	32
1000	SLC1012	2	1/6	12	12 1/8	4 1/16	5 15/16	12 1/2	32

Note: For complete dimensional data, refer to Coffing Dimensional Databook





MODEL
EMC / EMW

The **SOLUTIONS**
for **LIGHT DUTY**
APPLICATIONS

EMC & EMW Models



300 & 500 lb.

Made in USA



500 lb.

Made in USA

COFFING EMC & EMW Models - Compact chain and wire rope hoists designed for a variety of light duty applications. These models feature thermally protected motors.

CAPACITIES & LIFT - Rated loads 300 and 500 pounds. 10-foot lift with 6-foot push button cord standard.

VOLTAGES - 115V, single phase motors only.

SUSPENSION - Swivel top and bottom hooks with safety latches standard.

POWER CORD - Provided with grounded 3-prong plug for easy installation in any standard 115V outlet.

ALUMINUM HOUSING - Lightweight and compact to provide strength and portability. Weighs less than 25 lb.

LIMIT SWITCHES - Upper and lower limit switches on chain models and upper paddle limit switch on wire rope model regulates load travel.

ELECTROMAGNETIC BRAKE - Quick acting for positive load control.

THERMAL MOTOR PROTECTION - Standard to prevent overheating.

LIGHT DUTY OPERATION - Rated for intermittent duty applications (10-minute run time per hour maximum).

ACCESSORIES - LCC-05 chain container (shown) available for EMC models.

UL LISTED

LIFETIME WARRANTY

● SPECIFICATIONS ●

EMC & EMW Models

Capacity (lb.)	Model Number	No. of Chains	Standard Lift (ft.)	Motor HP	Lift Speed (fpm)	Headroom (in.)	Housing Dimensions (in.)			Net Wt. (lb.)
							H	W	L	
300	EMC-300B	1	10	1/6	16	14 1/2	4 3/8	6 3/8	14 1/4	21
500	EMC-500B	2	10	1/6	8	16	4 3/8	6 3/8	14 1/4	24
500	EMW-500B	2-part wire rope	10	1/6	16	13 3/4	4 3/8	6 3/8	14 1/4	19

Note: For complete dimensional data, refer to Coffing Dimensional Databook

COMPACT and PORTABLE HOISTING MADE EASY

ELECTRIC CHAIN HOISTS

MODEL
ESC



ESC Hoist

COFFING ESC Models - Design which includes many safety features you would expect to find in larger, more expensive hoists.

CAPACITIES & LIFT - Rated loads 1/4 and 1/2 Ton. 10 and 20-foot lifts standard. Standard push button is 4-feet less than lift.

VOLTAGES - 115/1-60/50 with transformer.

SUSPENSION - Rigid top and swivel bottom hooks with safety latches standard.

POWER CORD - Provided with grounded 3-prong plug for easy installation in any standard 115V outlet.

ALUMINUM HOUSING - Lightweight and compact to provide strength and portability. Weighs less than 25 lb.

LIMIT SWITCHES - Upper and lower limit switches regulate load travel.

HELICON™ GEARS - Hardened steel, self-locking gears work as a brake to hold load even if power is interrupted. Permanent lubrication of gears minimizes maintenance.

CHAIN - Manganese alloy load chain is heat treated for high strength.

LOAD SHEAVE - Heat treated steel alloy load sheave provides smooth lifting.

OVERLOAD SENSOR - Protects hoists against jamming and dangerous overloads. Red light on underside of unit alerts operator if overload is attempted.

CHAIN CONTAINER - Standard on all models.

PUSH BUTTON STATION - Ergonomic design fits operator's hand for easy operation.

LIGHT DUTY OPERATION - Rated for intermittent duty applications (10-minute run time per hour maximum)

LIFETIME WARRANTY



1/4 & 1/2 Ton

Made in USA

● SPECIFICATIONS ●

ESC Models

Capacity		Model Number	No. of Chains	Standard Lift (ft.)	Motor HP	Lift Speed (fpm)	Headroom (in.)	Housing Dimensions (in.)			Voltage (1 phase)	Net Wt. (lb.)
(lb.)	(Ton)							H	W	L		
500	1/4	ESC0512-10	1	10	0.3	12	14 1/4	4 1/4	5 1/4	9 3/4	115V	16
500	1/4	ESC0512-20	1	20	0.3	12	14 1/4	4 1/4	5 1/4	9 3/4	115V	18
1000	1/2	ESC1006-10	2	10	0.3	6	14 1/4	4 1/4	5 1/4	9 3/4	115V	20

Note: For complete dimensional data, refer to Coffing Dimensional Databook



MODEL
WR

**INDUSTRIAL
DUTY
WIRE ROPE
HOISTS**



1/2 - 5 Ton
Made in USA

WR Wire Rope Models

COFFING WR Models – Incorporates the High Performance Engineering of the Coffing Brand with additional advantages of wire rope. The Coffing WR models feature: a mechanical load brake; motor brake; and overload protection as standard.

CAPACITIES & LIFT - Rated loads from 1/2 to 5 tons, with lifts from 15 ft. to 70 ft. based on models. Standard push button drop is 4 ft. less than lift.

VOLTAGES & MOTOR OPTIONS – 115/230 (single phase); 230/460, 208, 220/380, 575 (three phase) 60 hertz or 50 hertz. Two-speed motors available (3 to 1 speed ratio).

REEVING OPTIONS – WR Models are available with 2-part standard; 4-part standard; True Vertical Lift; and Low Headroom options.

SUSPENSION OPTIONS - Hoist can be Lug, Plain, Geared, or Motorized Trolley mounted.

ADJUSTABLE LIMIT SWITCH – Regulate upper and lower load travel. Stainless steel and brass components provide exceptional repeatability and positioning.

OIL BATH TRANSMISSION – Gears are precision machined of alloy steel and run in an oil bath for longer, quieter operation.

SMALL FRAME DESIGN - Features housings of cast aluminum alloy construction for minimum weight. Engineered and designed for use with motors up to 1 HP.

LARGE FRAME DESIGN - Features load bearing housings of ductile iron construction for maximum strength. Non-load bearing housings of cast aluminum alloy for minimum weight. Engineered and designed for use with higher torque 2 and 3 HP three phase motors.

MACHINED STEEL DRUM – Precision grooves are machined to a depth 50% of the wire rope diameter.

VFD OPTION – Under-the-cover Variable Frequency Drives offer In-field, instant programming - from infinitely variable (12:1 speed ratio) to any intermediate, predetermined speed range. VFD's can also be externally mounted to Motorized Trolley Units.

OTHER OPTIONS & ACCESSORIES – Corrosion resistant stainless steel wire rope available. For other options and accessories, see pages 28-30

● **SPECIFICATIONS** ●

Wire Rope Models

Capacity		Model Number	Frame Size	Optional Reeving	Motor HP	Lifting Speed (fpm)	Headroom (in.)	Weight (lb.)
(lb.)	(Ton)							
1000	1/2	WR1010	S	S, TVL, LH	1/2	10	20	107
1000	1/2	WR1016	S	S, TVL, LH	1/2	16	20	107
1000	1/2	WR1021	S	S, TVL, LH	1	21	20	181
1000	1/2	WR1032	S	S, TVL, LH	1	32	20	181
2000	1	WR2010	S	S, TVL, LH	1	10	20	181
2000	1	WR2016	S	S, TVL, LH	1	16	20	181
2000	1	WR2028	L	S, TVL, LH	2	28	26 1/4	371
4000	2	WR4014	L	S, TVL, LH	2	14	26 1/4	371
4000	2	WR4021	L	S, TVL, LH	3	21	26 1/4	380
6000	3	WR6010	L	S	2	10	27 1/6	446
6000	3	WR6014	L	S	3	14	27 1/6	455
6000	3	WR6016	L	TVL, LH	5	16	24 5/8	1080
6000	3	WR6026	L	TVL, LH	5	26	24 5/8	1080
10000	5	WR10016	L	TVL, LH	5	16	24 5/8	1080

Note:
For complete dimensional data, refer to Coffing Dimensional Databook

**COFFING®
HOISTS**

WR HOIST CUTAWAY VIEW

HIGH
PERFORMANCE
LIFTING

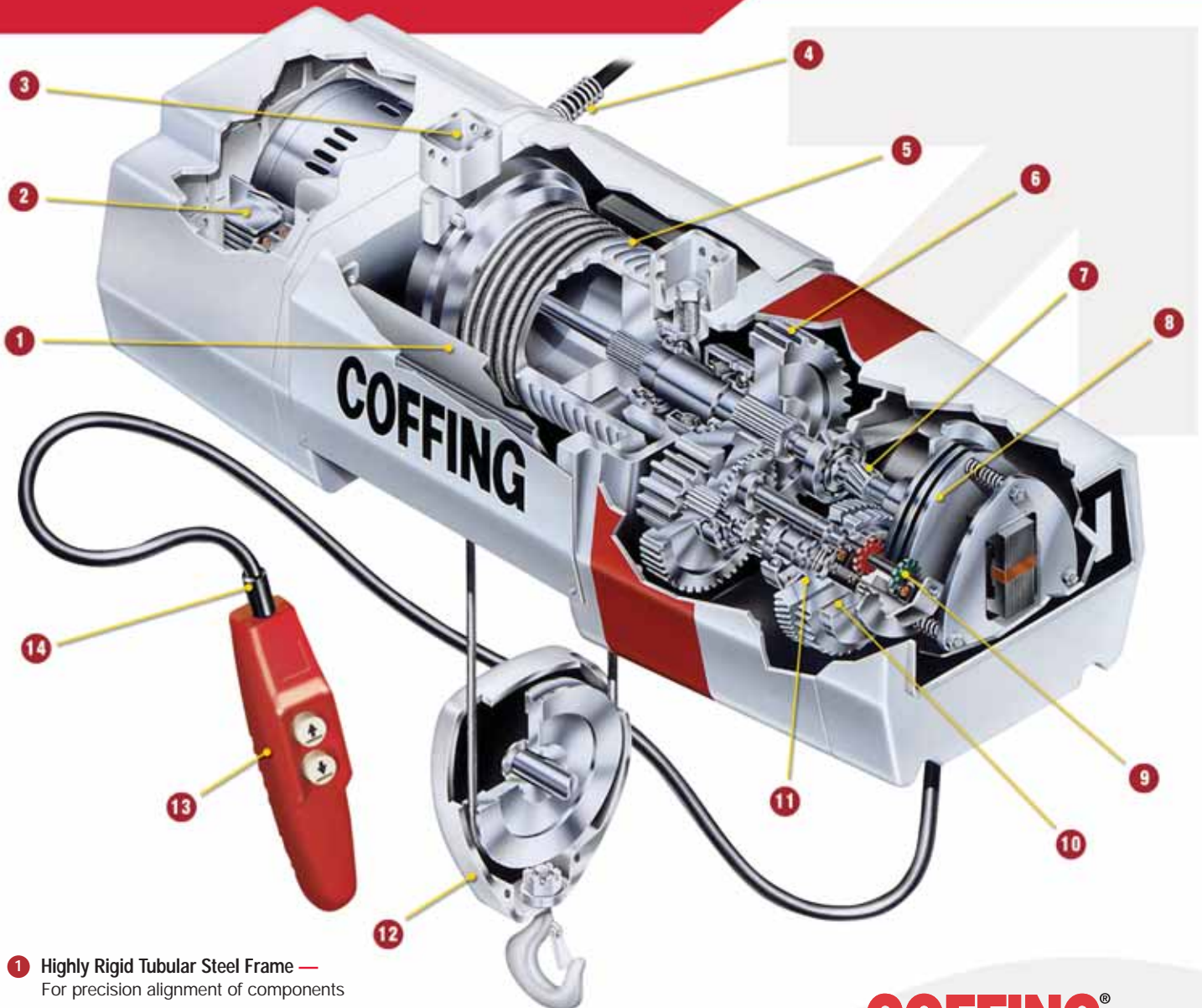

- 1 Highly Rigid Tubular Steel Frame —**
For precision alignment of components
- 2 Easy Access to All Electrical Connections**
- 3 Dual Articulating Trolley Lugs —**
Provide excellent curved beam traveling characteristics.
- 4 Threaded Power Cord Entry —**
Weather Tight
- 5 Steel Machined Groove Drum —**
Provides smoother winding and longer rope life.
- 6 Precision Machined Alloy Steel Gears —**
Lubricated by oil bath for longer, quieter operation.
- 7 First Stage Helical Gearing —**
Quietest operation available

- 8 Multiple Disc Motor Brake —**
Direct acting to stop load when push button is released and power off.
- 9 Adjustable Upper and Lower Limit Switches —**
For regulated load travel.
- 10 Mechanical Load Brake —**
Multiple disc type for load lowering control and additional reliability.
- 11 Standard Overload Clutch —**
Protects against damage caused by excessive overloads and reverse phasing.
- 12 Fully Enclosed Bottom Block —**
Guards against rope jamming and sheave damage.

- 13 Ergonomic Push Button Control —**
Impact and chemical/corrosive atmosphere resistant. Our push button station fits operator's hand for thumb or two-handed operation. 24 Volt Control standard for operator safety. 115 Volt Control available upon request. NEMA 3R (weather resistant) standard.
- 14 Internal Strain Relief —**
Provides support for push button station

COFFING®
HOISTS



MODEL
MT

**SMOOTH
and RELIABLE
OPERATION**



1/4 - 5 Ton

Made in USA

MT Motorized Trolley

COFFING MT Model Trolley - Features rugged construction with wrap-around side plates and heat treated wheels for reliable service. Universal clevis allows quick mounting of most hook mounted electric chain hoists.

CAPACITIES - Rated loads from 1/4 to 5 Tons. Push button drop is 6-feet.

VOLTAGES - 115/230, 208 - single phase; 230/460, 208, 220/380, 575 - three phase. 60 hertz standard, 50 hertz available.

SPEEDS - 35 and 75 FPM speeds standard with optional speeds of 18, 24, 50, 100, and 150 FPM.

TWO-SPEED MODELS - Optional with 3 to 1 speed ratio, three-phase, single voltage only. Slow speed feature for gentler start and greater positioning accuracy.

MOUNTING - Universal clevis will accept top hook models. Can change EC and JLC suspensions to lug mount directly to MT trolley — consult factory.

TROLLEY DESIGN - 4-wheel design on 1/4 - 3 Ton and under. 8-wheel design on 4 and 5-Ton for reduced beam flange stresses. Specify track type and beam size.

NEMA 3R PUSH BUTTON - Ergonomic design fits operator's hand for thumb or two-handed operation. 24 Volt Control standard for operator safety. 115 Volt Control available upon request.

ACCESSORIES - Trolley brake and other options available to meet a variety of applications.

LIFETIME WARRANTY

● **SPECIFICATIONS** ●

MT Motorized Trolley

Capacity			Model Number	Motor HP	Trolley Speed *	Flange Width (in.)	Min. Rad. Curve (in.)	Net Wt. (lb.)
(lb.)	(kg) †	(Ton)						
500	250	1/4	MT-05035	1/4	35 or 75	3.332 - 7	48	115
500	250	1/4	MT-05075	1/4	35 or 75	3.332 - 7	48	115
1000	500	1/2	MT-10035	1/4	35 or 75	3.332 - 7	48	115
1000	500	1/2	MT-10075	1/4	35 or 75	3.332 - 7	48	115
2000	1000	1	MT-20035	1/4	35 or 75	3.332 - 7	48	115
2000	1000	1	MT-20075	1/4	35 or 75	3.332 - 7	48	115
3000	1500	1 1/2	MT-30035	1/4	35 or 75	3.332 - 7	48	115
3000	1500	1 1/2	MT-30075	1/4	35 or 75	3.332 - 7	48	115
4000	2000	2	MT-40035	1/4	35 or 75	3.332 - 7	48	115
4000	2000	2	MT-40075	1/4	35 or 75	3.332 - 7	48	115
6000	3000	3	MT-60035	1/4	35 or 75	3.332 - 7	48	115
6000	3000	3	MT-60075	1/2	35 or 75	3.332 - 7	48	115
8000		4	MT-80035	(2) 1/4	35 or 75	4 - 7	***	220
8000		4	MT-80075	(2) 1/2	35 or 75	4 - 7	***	220
10000	5000	5	MT-100035	(2) 1/4	35 or 75	4 - 7	***	220
10000	5000	5	MT-100075	(2) 1/2	35 or 75	4 - 7	***	220

*** 4 & 5 Ton - straight track only. Articulated model for 48" min. radius curved track available — consult factory.

† Metric rated option available.

Note: For complete dimensional data, refer to Coffing Dimensional Databook.



HOIST SUSPENSIONS

EC Small Frame



Standard Top Hook
with safety latch-rigid
(standard) or swivel.



Optional Bullard Hook*
with return latch, with or
without return spring, for
added safety.



Optional Shur-Loc® Hook*
with positive lock latch is self-
locking when hook is loaded.



**Optional
Multi-Purpose Lug**
available for special
applications.



Rigid Lug
for mounting CTA and MT
trolleys to small frame EC
models.



Rigid Lug
for mounting CTA and MT
trolleys to EC-6005 model only.

EC Large Frame



Standard Top Hook
with safety latch-rigid
(standard) or swivel.
1, 2, 3, and 4 ton only.



Optional Bullard Hook*
with return latch, with or
without return spring.
1, 2, 3, and 4 ton only.



**Optional
Shur-Loc® Hook***
with positive lock latch
is self-locking when
hook is loaded.



Rigid Lug
for mounting CTA and
MT trolleys to large
frame EC models.
1, 2, and 3 ton only.



Rigid Lug
for mounting CTA and
MT trolleys to large
frame EC models.
4 and 5 ton only.

JLC Hoists



Standard Top Hook
with safety latch
standard.



Swivel Top Hook
with safety latch
standard.



**Optional
Shur-Loc® Hook***
with positive lock latch
is self-locking when
hook is loaded.



Rigid Lug
for mounting CBT,
CTA and MT trolleys.



ACCESSORIES

POWERED HOISTS

CHAIN CONTAINERS

- **Models** - To fit EC, ED, and JLC models.
- **Mounting** - Suspends from hoist and does not interfere with hoist operation. Suspension bracket included.
- **Safety** - Recommended where slack chain may create a hazardous condition.

EC Small and Large Frame Chain Containers



JLC Chain Containers



Model Number	Dimension (in.)	Capacity (In Feet Per Hoist Lift)		
		1-Chain Single	2-Chain Double	3-Chain Triple
<i>For Small Frame EC Models EC-0516 — EC-4008 (except EC-2032), EC-6005, and all ED Models</i>				
927JG17	10 7/16	20	10	N/A
927JG18	12 1/2	25	12.5	N/A
927JG19	16	35	17.5	12
927JG20	20 1/4	50	25	17
927JG202A	20	75	37	25
927JG203A	24	100	50	33
927JG204A	35	150	75	50
<i>For Large Frame EC Models EC-2032, EC-4016 — EC 10008 (except EC-6005)</i>				
927JG201	16	15	N/A	N/A
927JG202	20	30	15	10
927JG203	24	50	25	16.5
927JG204	35	75	37.5	25
927JG205	48 3/4	100	50	33.3
927JG207	26	150	75	50
927JG208	32	200	100	66.6
<i>For JLC Models — Molded Polyolefin Type</i>				
JLC927-1	20 1/2	20	10	N/A
JLC927-2	16	35	17	N/A
JLC927-3	20 1/4	50	25	N/A
JLC927-4	N/A	Over 50	25	N/A
<i>For JLC Models — Fabric Type</i>				
JLC927-20F	16	20	10	N/A
JLC927-35F	22	35	17 1/2	N/A
JLC927-50F	26	50	25	N/A
JLC927-70F	31	70	35	N/A

WEATHER RESISTANT COVERS

- **Models** - To fit EC and JLC models.
- **Material** - Waterproof to protect hoist in outdoor use.
- **Safety** - Does not interfere with normal hoist operation while in place.

Hoist Rated Load (lb.)	Type of Mount	Part Number
<i>For Small Frame EC Models EC-0516 — EC-4008 (except EC-2032)</i>		
500	Hook or Lug	EC-760-1
1000	Hook or Lug	EC-760-2
2000	Hook or Lug	EC-760-3
4000	Hook or Lug	EC-760-4
6000	Not Available	Not Available
<i>For Large Frame EC Models EC-2032, EC-4016 — EC-10008 (except EC-6005)</i>		
4000	Hook	EC-761-1
4000	Lug	EC-761-2
6000	Hook	EC-761-3
6000	Lug	EC-761-4
8000	Lug	EC-761-5
10000	Lug	EC-761-6

For All JLC Models:
Use JF-760





CORD REELS

Electrification Necessary For Electric Chain Hoists

- **Construction** - NEMA 3R all-welded, solid steel construction. UL and CSA listed.
- **Design** - Provides instant availability of power cord & prevents looping and snagging.
- **Ratchet Lock** - Works in any position to hold cord in place and may be disengaged for constant use.
- **Cable Guide** - Multi-position, field adjustable, and removable for different payout configurations.
- **Collector Assembly** - Rated at 600 volts.
- **Optional Pivot Base** - For 340° off-line payout.



Cable Size (AWG)	Model Number	Phase	Active Cable Length (ft.)
No. 14-3 Conductor	DN-3-25	1	25
No. 14-3 Conductor	DN-3-50	1	50
No. 14-4 Conductor	DN-4-25	3	25
No. 14-4 Conductor	DN-4-45	3	45

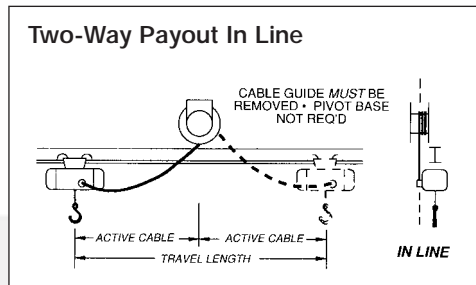
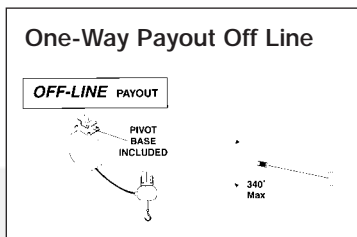
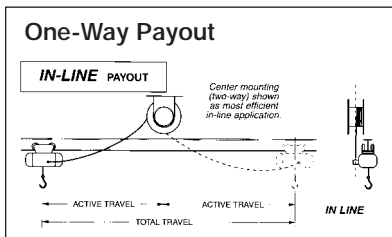

CURRENT COLLECTOR MOUNTING ARM

For Mounting Collectors or Towing Festooning

- **Mounting** - Direct to CT or MT trolleys.
- **One Inch Square Arm** - For use in mounting most makes of collectors or towing festooning.



High Performance Lifting
COFFING[®]
 HOISTS



TORQUE REELS

Used in Supporting and Suspending Hoist or Crane Push Button Stations

- **Construction** - Steel with reinforced hanging bracket and clevis for ceiling mounting.
- **Ratchet Lock** - Included but easily disengaged from outside housing for constant tension.
- **Optional Rigid Base** - Available for mounting to ceiling, wall, floor, or work bench.

Min - Max Load (lb.)	Model Number	Cable Length (ft.)	Reel Weight (lb.)
5 - 10	6KG319	15	10



FESTOONING PACKAGES

An Economical and Reliable Way to Supply Power to Moving Hoists

- **Flat Cable Kit** - Includes suspension wire and power cable.
- **Round Cable Kit** - Includes suspension wire but not power cable.

Flat Cable Festooning Package

Model Number	Cable Size (Gauge)	Length (ft.)	Number of Carriers
HEF-12-35	12	35	4
HEF-12-50	12	50	6

Round Cable Festooning Package

Model Number	Length (ft.)	Number of Carriers
HER-35	35	4
HER-50	50	6



CORD TROLLEYS

Keeps Power Cord From Interfering With Working Area

- **Adjustable** - For standard 3" to 10" American Standard I-Beams.
- **Usage** - One trolley recommended for every 5-feet of power cord.

Adjusts for Std. I-Beam (in.)	Model Number	Tread Diameter (in.)	Net Weight (lb.)
3 - 10	TL-3-10C	2 3/8	2 1/4





VARIABLE FREQUENCY DRIVES

INFINITELY VARIABLE SPEED CAPABILITY - AT THE PUSH OF A BUTTON

COFFING EC-V & JLC-V Models — *Redefining Lifting* — now feature a Variable Frequency Drive. The compact size of the drive unit allows neat and complete placement under the cover of the hoists. On EC-V Models, this new option enhances the standard hoist's features: mechanical load brake, motor brake and overload clutch. The Coffing JLC-V drives feature a Closed Loop System. The Closed Loop System provides additional load control in lieu of a secondary load brake by monitoring the movement of the load hook through the transmission.

VARIABLE FREQUENCY DRIVE BENEFITS – The VFD allows for unsurpassed load-spotting and inching capability. The VFD offers additional speed flexibility that standard 2-speed motors cannot offer. The soft starting and stopping of the unit is perfect for delicate applications and reduces the daily wear and tear on the hoist. Variable Frequency Drives can also be externally mounted to Motorized Trolley Units.



Variable Speed



VARIABLE FREQUENCY DRIVE FEATURES – In-field, instant programming - from infinitely variable (12:1 speed ratio) to any intermediate, predetermined speed range. 24-VAC control inputs built-in.

JLC-V Only - Closed Loop System that monitors the load hook's direction and speed; additional components monitor motor amperage to provide consistent and reliable operation.

CONTROL OPTIONS – The standard 2-step buttons allow the operator to increase and maintain the lifting or lowering speeds. The optional 3-step buttons allow the operator to increase, maintain, or decrease the lifting or lowering speeds without interruption.

CAPACITIES & LIFTS - EC-V Models - Rated loads from 1/4 to 5 Tons, with lifting speed of 5 to 64 feet per minute depending on the capacity. Standard lifts of 10, 15, and 20 with other lifts available. Standard push-button drop is 4-feet less than lift.

JLC-V Models - Rated loads from 1/8 to 2 Tons, with lifting speed of 8 to 32 feet per minute depending on the capacity. Standard lifts of 10, 15, and 20 with other lifts available. Standard push-button drop is 4-feet less than lift.

VOLTAGE & MOTOR OPTIONS - 230; 460; 208; 380; 575 – three phase. 60 hertz standard or 50 hertz available.

SUSPENSION OPTIONS - Rigid or swivel top hook, lug, plain, geared, and motorized trolley available.

DURABLE CONSTRUCTION - Built in compliance with ASME/ANSI B30.16.

ACCESSORIES & OPTIONS - Full line available to meet a variety of applications.

LIFETIME WARRANTY

MADE IN USA



REMOTE CONTROL PACKAGES

For Specialized Hoist and Crane Applications



- Radio and Infrared Models Available - Consult factory.

CORROSION RESISTANT FEATURES

Protects Hoist in Corrosive Environments

Consult Factory to Verify Availability on Desired EC & JLC Models Only



- **Features** - Zinc plated load chain, zinc plated hand chain, zinc plated hook, stainless steel limit switch shaft, stainless steel wheels, bronze wheels, epoxy paint.

SPARK RESISTANT FEATURES

Reduces Chance of Sparking

Consult Factory to Verify Availability on Desired EC Models Only



- **Features** - Stainless steel load chain, stainless steel hooks, bronze hooks, aluminum hand chain, stainless steel bottom block assembly, stainless steel trolley wheels, bronze trolley wheels, and rubber trolley bumpers.



ADDITIONAL FEATURES *Consult Factory*

- Paddle Limit Switch
- Electronic Overload Sensor
- Trolley Limit Switches
- Wall-Mounted Push Button Stations
- NEMA 1, 2, 3R, 4X, 5, 12 & 13 PB Stations
- 3 - Foot Outrigger Arm
- Circuit Breaker
- Motor Fuses
- Mainline Contactor
- Solid State Trolley Soft Start
- Electrical Interlocks
- External Strain Relief
- Electronic Phase Reversal & Under Voltage Protection
- Magnetic Particle Inspection
- Horn or Bell
- Kellems Cord Grip
- Bridge or Tractor Controls
- Track Clamp
- Motor Thermostat
- Thermal Overload Relay
- Trolley Ballast Resistors (3-Phase Only)
- Multi-Button Push Button Stations
- Timers
- Retractable Coil Cord

SPECIAL APPLICATIONS *Consult Factory*

Tandem Applications

- Twin hooks move long, unwieldy loads.
- Push button control station allows hoists to be operated either simultaneously or individually.
- Hoists connected mechanically or electrically.
- Available with plain, geared, and motorized trolleys.

Twin Hook

- Same as tandem trolley application, except hoist has hook or lug suspension for fixed position operation.

Semi-Automatic

- Requires only a momentary depression of push button to raise or lower hook to preset position.
- Limit switch permits adjustment of end stops anywhere within range of lifts.
- Stop button allows stops between limits.

Multi-Level

- Hoist can be specified with multiple control pendants or wall stations.

Inching Controls

- Selector switch allows hoist operation in normal or jog mode.
- In jog mode, each depression of button advances hook a fraction of an inch. (Field adjustable)
- Can be supplied with jog adjustment potentiometer inside hoist enclosure or on push button station.

Patented Carrier

- Rated load from 1/4 to 3 Tons
- On request, hoist units can be furnished with suitable lugs for mounting on patented track carriers.

Key Lock

- Key lock on push buttons prevent unauthorized hoist use.
- Multiple stations keyed unlike—unless specified.



MODEL SLA

AIR POWER For WORKSTATIONS and PRODUCTION LINES

SLA Model Air Chain Hoist



250 - 1000 lb.

Made in USA

COFFING SLA Models - Heavy-duty, lightweight and rugged with compact design—for ease of portability. This powerful and reliable hoist is perfect for most air hoist lifting applications including work stations and production lines – up to 1000 lbs.

CAPACITIES - 250, 300, 500, 600, 1000 lb.

SPEEDS - Under Full Load - **250 & 300 lb. models:** 31 FPM Lifting / 83 FPM Lowering, **500 & 600 lb. models:** 16 FPM Lifting / 42 FPM Lowering **1000 lb. models:** 11 FPM Lifting / 42 FPM Lowering

AIR PRESSURE - Normal operating pressure is 90 PSI

HEADROOM - 10 7/8" headroom - 250 & 300 lb. models

OVERLOAD PROTECTION - Standard Protector™ overload device.

EXTENDED SERVICE LIFE - 10-pocket oblique lay liftwheel provides longer chain life.

DURABLE EXTERIOR - Epoxy powder coat finish is smooth and tough.

RELIABLE OPERATION - Double reduction gearing.

ON-THE-MONEY - Variable flow, two lever pendant for precise load spotting.

EXHAUST OPTION - Threaded external exhaust for piping away exhaust in clean room or painting operations.

TOUGH AND COMPACT - Rugged cast aluminum alloy hoist frame. Small, compact design for commercial and industrial applications.

AIR POWER - Industrial-duty air motor for tough applications.

LIFETIME LUBE - Gear train is lifetime-lubricated with non-oxidizing grease.

POSITIVE LOAD ENGAGEMENT - Hardened, forge steel, latch-style lower hook rotates 360°. Upper hook provided with latch for positive load engagement.

LIFETIME WARRANTY

● SPECIFICATIONS ●

SLA Air Chain Hoist

Capacity (lb.)	Model Number	No. of Chains	Full Load Hoist Speed (FPM)	Full Load Lowering Speed (FPM)	Headroom (in.)	Housing Dimensions (in)			Shipping Weight (lb.)
						H	W	L	
250	SLA0231	1	31	83	10 7/8	4 1/16	6 17/25	12 27/32	30
300	SLA0331	1	31	83	10 7/8	4 1/16	6 17/25	12 27/32	30
500	SLA0521	1	21	83	10 7/8	4 1/16	6 17/25	12 27/32	30
500	SLA0516	2	16	42	11 15/16	4 1/16	6 17/25	12 27/32	34
600	SLA0616	2	16	42	11 15/16	4 1/16	6 17/25	12 27/32	34
1000	SLA1011	2	11	42	11 15/16	4 1/16	6 17/25	12 27/32	34

Note: For complete dimensional data, refer to Coffing Dimensional Databook



CONTINUOUS DUTY- PRECISE POSITIONING

AIR POWERED HOISTS

MODEL
AC



AC Model Air Powered Hoist

COFFING AC Models - Air chain hoists featuring continuous duty service for precise, infinitely variable speed and accurate load spotting.

CAPACITIES & LIFT - Rated loads 1/4 to 6 Tons. 10, 15, and 20-foot standard. Other lifts available.

CONTROLS - Standard rope pull cord is 3-feet less than lift. Optional twist rod, lever pendant, and hook-mounted controls available.

SUSPENSION - Swivel top and bottom hooks with safety latches standard. Air trolley available in 3 and 6 tons — consult factory.

SPEEDS - Precise and infinitely variable speed control for accurate load spotting. 90 PSI air operating pressure.

COMPACT CONSTRUCTION - Ideal for use in areas with restricted space. Lightweight and portable - 1/4, 1/2 & 1 ton units weigh less than 50 lbs.

MOTOR - Rotary vane type motor provides for high uniform torque and quick response. Bronze muffler built into valve housing for quiet operation.

PLANETARY GEARS - Designed to withstand continuous operation at full load. Permanently lubricated for long life.

DISC TYPE MOTOR BRAKE - Releases automatically when motor shaft rotates in hoisting direction and sets with slight motor shaft rotation in lowering direction. Designed to eliminate load drift.

MAIN VALVE - Air balanced, spring centered unit provides smooth starts and excellent inching characteristics.

LIMIT SWITCHES - Upper and lower paddle limit switch with plugging to regulate load travel.

LIFETIME WARRANTY



1/4 - 6 Ton

● SPECIFICATIONS ●

AC Model Air Powered Hoists

Capacity			Model Number	No. of Chains	Standard Lifts (ft.)	Lift Speed (fpm)	Headroom (in.)	Housing Dimensions (in.)			Air Pressure (psi)	Net Wt. (lb.)
(lb.)	(kg) †	(Ton)						H	W	L		
500	250	1/4	AC-0500	1	10, 15, 20	61	14 13/16	9 1/4	4 15/16	15 3/8	90	37
1000	500	1/2	AC-1000	1	10, 15, 20	41	14 13/16	9 1/4	4 15/16	15 3/8	90	37
2000	1000	1	AC-2000	2	10, 15, 20	21 1/2	17 1/2	9 1/4	4 5/8	15 3/8	90	46
6000	3000	3	AC-6000	1	10, 15, 20	10 1/2	22 5/8	10	8 5/16	21 1/2	90	109
12000	6000	6	AC-12000	2	10, 15, 20	5 1/4	30 7/8	10	9 13/16	21 1/2	90	175

† Metric rated option available.

Note: Speed and air consumption figures should be used only as estimates of hoist performance. Actual data may vary plus or minus 15% because of individual motor characteristics. Do not operate AC hoists at an air pressure of greater than 100 psi. A 1/2" NPT air filter-regulator-lubricator is recommended for optimum operation.

Air Consumption Data

Capacity			Full Load		Half Load	
(lb.)	(kg)	(Ton)	(fpm)	(cfm)	(fpm)	(cfm)
500	250	1/4	61	76	86 1/2	91
1000	500	1/2	41	78	71	104
2000	1000	1	21 1/2	77	35 1/2	101
6000	3000	3	10 1/2	84	16	106
12000	6000	6	5 1/4	84	8	106

Note: For complete dimensional data, refer to Coffing Dimensional Databook



MODEL
CAH
Small Frame

**ACCURATE
LOAD SPOTTING—
CONTINUOUS
DUTY**

CAH Small Frame Model Air Hoists

Coffing CAH Small Frame Models - Small frame air chain hoists featuring accurate load spotting for specialized lifting applications.

CAPACITIES & LIFT - Rated loads of 1/4, 1/2, and 1 ton. 10-foot standard lift, longer lifts available.

CONTROLS - Pull Cord provides a lightweight, economical option for accurate control of loads. Pendant Throttle provides one-hand control, for ease of operation. 6-foot control drop length for 10-foot lift (4-foot less than lift—standard).

CHAIN OPTIONS - Link-type or roller-type load chain.

SUSPENSION - Swivel top and bottom hooks with safety latches standard. Rigid top hook, lug, plain, geared, and air motor trolleys available.

COMPACT CONSTRUCTION - Ideal for use in areas with restricted space. Aluminum housing provides strength and portability.

MOTOR - 8-vane motor provides high torque, smooth starting, and excellent load control.

LIMIT STOPS - Prevent over-travel in upper and lowering directions.

BRAKE - Heavy-duty shoe-type with proven design for stopping and holding loads. Externally adjustable.

SPARK RESISTANT MODELS - Rated loads of 3/8 and 3/4 ton.

OPTIONS - Chain container available. Plated chain optional for corrosion resistance.

AIR SUPPLY - Inlet size: 3/8" NPTF; Supply hose: 1/2" I.D. min. Exhaust: 1/2" NPTF; Consumption: 48 SCFM at 90 PSI.

LIFETIME WARRANTY



1/4 - 1 Ton

Made in USA

Trolleys for CAH Models:
For Hook Mounted Hoists - see page 50
For Lug Mounted Hoists - see pages 38, 39

● SPECIFICATIONS ●

CAH Small Frame Air Chain Hoist

Capacity		Type of Chain	Model Number		Number of Chains	Lift Speeds ** (fpm)		Headroom ‡ (in.)	Air Pressure (psi)	Net Weight † (lb.)
(lb.)	(Ton)		Pull Cord	Pendant Throttle *		Lifting	Lowering			
500	1/4	Link	CAH-0565-LC	CAH-0565-LP	1	65	95	15 1/4	90	36
1000	1/2	Link	CAH-1045-LC	CAH-1045-LP	1	45	120	15 1/4	90	36
2000	1	Link	CAH-2023-LC	CAH-2023-LP	2	23	60	18	90	49
500	1/4	Roller	CAH-0565-RC	CAH-0565-RP	1	65	95	15 1/4	90	37
1000	1/2	Roller	CAH-1045-RC	CAH-1045-RP	1	45	120	15 1/4	90	37
2000	1	Roller	CAH-2023-RC	CAH-2023-RP	2	23	60	18	90	51
Spark Resistant Models										
750	3/8	Link	CAH-0760-CS	CAH-0760-PS	1	60	100	15 1/4	90	36
1500	3/4	Link	CAH-1529-CS	CAH-1529-PS	2	29	52	18	90	49

* Equipped w/ 6-foot pendant control.

† Add 10 lbs. to Pull Cord Model for Net Weight on Pendant Model.

‡ Headroom dimension given for swivel top hook suspension only

** Speeds based on 90 PSI line pressure and with full rated load.

NOTE: Hoist speeds are adjustable and can be reduced. Shipped from factory w/ hoisting speed set to maximum rated speed; lowering speed set at rated speed.

CAH
SMALL FRAME
**CUTAWAY
VIEW**

**HIGH
PERFORMANCE
LIFTING**

Planetary Gearing

Heat treated alloy steel spur gears are accurately machined to provide a close meshed, compact gear reduction.

**Aluminum Frame, Cover
and Control Head**

Lightweight and portable. Designed for strength and ruggedness.

Inlet Air Swivel

Provides free hoist movement with built-in screen

Heavy Duty Shoe-Type Brake

Proven design for stopping and holding in heavy-duty applications. Externally adjustable.

Limit Lever

Prevents overtravel in both lifting and lowering directions.

Controls

Pull cord provides an economical option for accurate load control. Pendant throttle offers ergonomic one-hand control for ease of operation.

8-Vane Motor

Provides high-torque, smooth starts, and excellent control.

**External Speed
Adjustment Screws**

Convenient adjustment for both lifting and lowering speeds

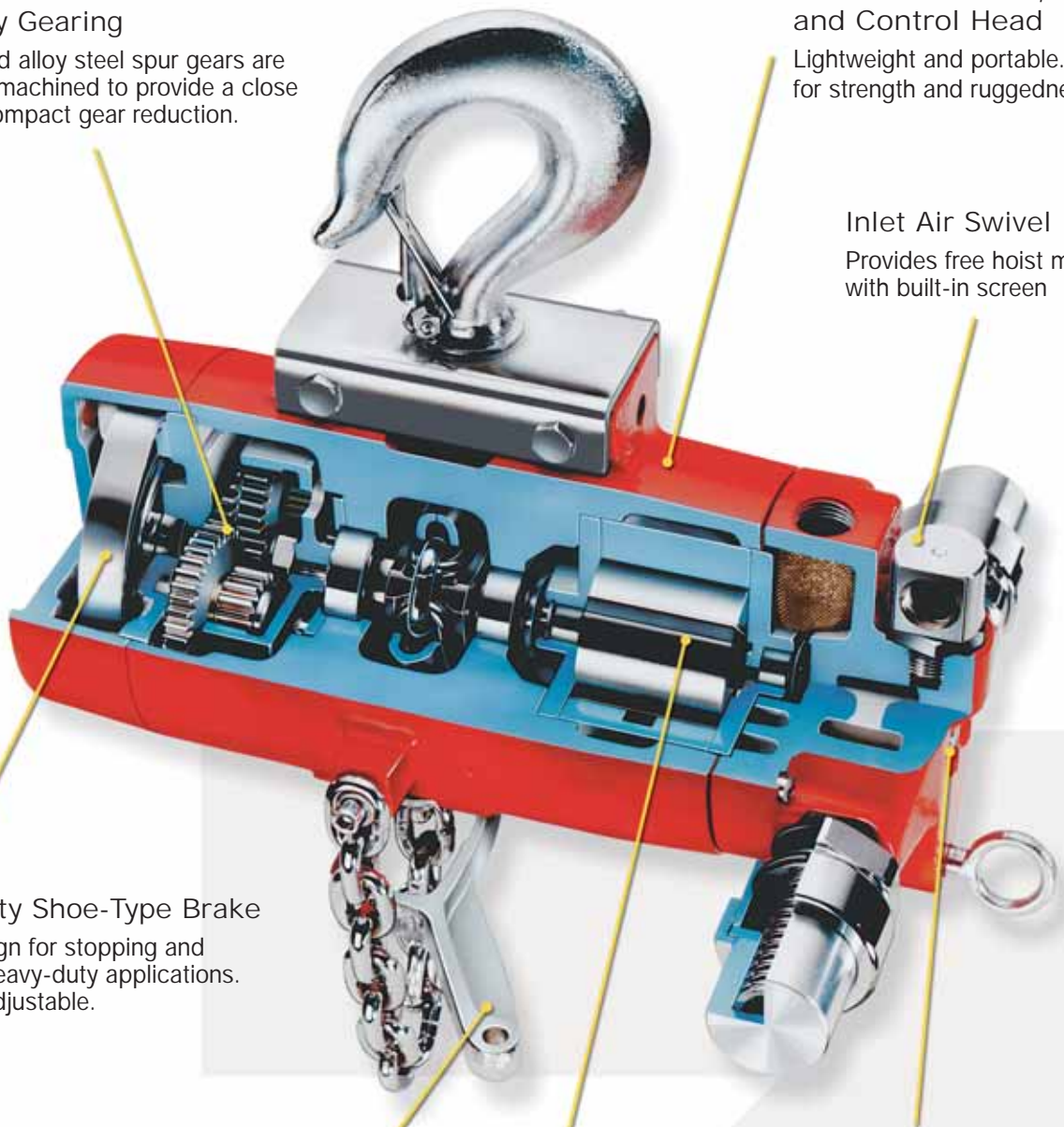



AIR POWERED HOISTS

MODEL
CAH
Large Frame

**VARIABLE
SPEED CONTROL-
SMOOTH
OPERATION**

CAH Large Frame Model Air Hoists



1/2 - 3 Ton

Made in USA

COFFING CAH Large Frame Models - Large frame air chain hoists featuring continuous duty service for precise, infinitely variable speed and accurate load spotting.

CAPACITIES & LIFT - Rated loads of 1, 2 & 3 ton. 10-foot standard lift, longer lifts available.

CONTROLS - Pendant throttle is full-flow design. 6-foot pendant hose length for 10-foot lift (4-foot less than lift—standard).

THROTTLE VALVE - Precision throttle valves meter air for smooth starts.

SUSPENSION - Swivel top and bottom hooks with safety latches standard. Rigid top hook, lug, plain, geared, and air motor trolleys available.

SPEEDS - Precise and infinitely variable speed control for accurate load spotting. 90 PSI air operating pressure.

ALUMINUM HOUSING - Lightweight, compact, and strong.

MOTOR - 8-vane rotary air motor produces high, uniform torque and quick response. Internal muffler for quiet operation.

GEARING - Combination of precision cut, heat-treated helical and spur gears for efficient operation.

MECHANICAL LOAD BRAKE - Positive acting Weston-type load brake holds the load and provides exacting load spotting and control.

OVERLOAD CLUTCH - Protects hoist, operator, and supporting structures from damaging overloads. Clutch acts as upper and lower limits.

SPARK RESISTANT MODELS - Rated loads 1/2, 1 & 2 ton.

OPTIONS - Corrosion resistant models and chain containers also available.

AIR SUPPLY - Inlet size: 3/4" NPTF; Supply hose: 3/4" I.D. min.

LIFETIME WARRANTY

Trolleys for CAH Models:

For Hook Mounted Hoists - see page 50

For Lug Mounted Hoists - see pages 38, 39

• SPECIFICATIONS •

CAH Large Frame Air Chain Hoist

* Speeds based on 90 PSI line pressure and with full rated load.

† Headroom dimension given for swivel top hook suspension only.

Air Consumption: 70 SCFM (full load - full speed) slow speed model; 80 SCFM (full load - full speed) fast speed model.

Standard lift 10 ft.
Longer lifts are available

NOTE: For complete dimensional data, refer to Coffing Dimensional Databook.

Capacity		Model Number	Number of Chains	Lift Speeds *		Headroom † (in.)	Air Pressure (psi)	Net Weight (lb.)
(lb.)	(Ton)			Lifting	Lowering			
2000	1	CAH-2013	1	13	18	16 9/16	90	93
2000	1	CAH-2030	1	30	42	16 9/16	90	95
4000	2	CAH-4006	2	6	9	22 1/4	90	110
4000	2	CAH-4015	2	15	21	22 1/4	90	112
6000	3	CAH-6004	3	4	6	24	90	144
6000	3	CAH-6010	3	10	14	24	90	146
Spark Resistant Models								
1000	1/2	CAH-0516-S	1	16	22	16 3/4	90	95
2000	1	CAH-1008-S	2	8	11	22 7/8	90	112
4000	2	CAH-2005-S	3	5	7	25 7/8	90	146

CAH LARGE FRAME CUTAWAY VIEW

HIGH
PERFORMANCE
LIFTING

Multi-Vane
Rotary Air Motor
8-vane rotary design provides:

- High torque
- Smooth operation
- Positive starting
- Excellent load control

Aluminum Frame & Cover
Lightweight aluminum housing offers:

- Rugged holding shafts and bearings in close alignment.

Infinitely Variable Speed Control
Full-flow pendant design offers operator exacting throttle control:

- Precise throttle valves meter air flow for smooth operation

Combination Gearing
Model CAH hoists combine efficient gearing that features:

- Precision cut, heat-treated helical and spur gear combination
- Quiet, efficient operation

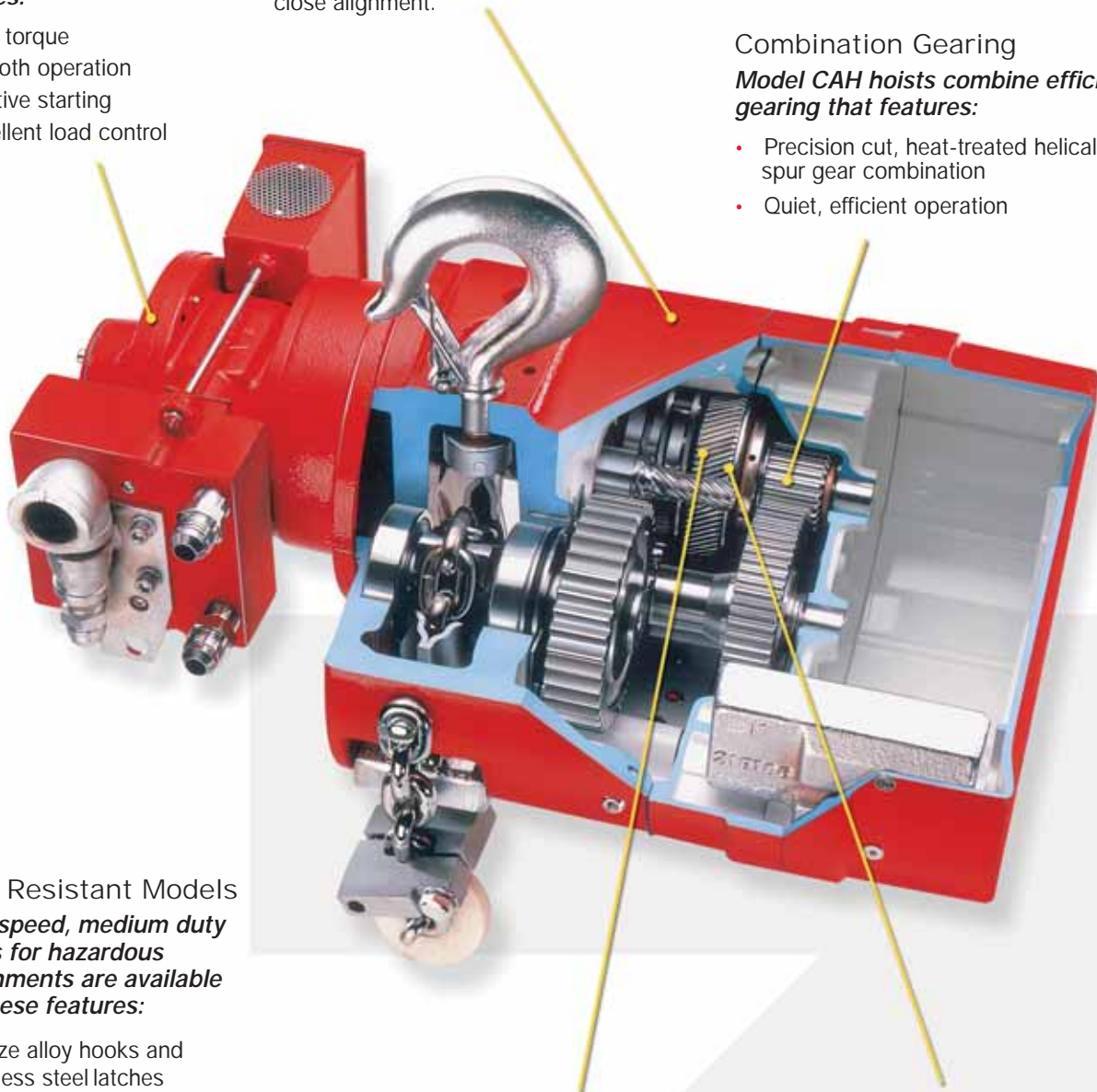

Spark Resistant Models
Lower speed, medium duty models for hazardous environments are available with these features:

- Bronze alloy hooks and stainless steel latches
- Chrome nickel non-magnetic stainless steel alloy load chain
- Bronze limit stop with aluminum limit actuators and modified sprocket and guide

Mechanical Load Brake
Positive acting Weston-type load brake

- Holds the load effectively
- Provides exacting load spotting and control

Overload Protection
Overload device helps ensure smooth, safe operation:

- Protects against excessive overloads
- Clutch acts as upper and lower limits of chain travel



1/2 - 2 Ton

Made in USA

HT Model Spark Resistant Trolley

For CAH Model Air Hoists

COFFING Model HT - Hook suspension trolleys are available in plain and hand-gear versions to operate on either American Standard I-beams or wide flange beams.

CAPACITIES - Rated loads from 1/2 to 2 ton; plain and geared models.

PLAIN TROLLEY - For manual positioning of hoist and load.

GEARED TROLLEY - For more precise positioning of hoist and load. Geared trolleys have standard 9' 6" hand chain drop.

CONSTRUCTION - Trolley side plates are all-steel for maximum strength. Equipped with beryllium copper wheels and vinyl covered bumpers.

ADJUSTABLE - Trolley easily adjusts to fit any beam flange within range of adjustment.

UNIQUE DESIGN - For use with hook suspension Coffing CAH air hoists.

WRAP-AROUND SIDE PLATES - Act as safety lugs to increase operator safety and as bumpers to protect wheels.

METRIC RATED

LIFETIME WARRANTY

High Performance Lifting
COFFING[®]
HOISTS

For Hook Mounted CAH Models -
See CBT Trolley, Page 50

● SPECIFICATIONS ●

Model HT Plain & Geared Trolleys

Capacity		Model Number *	Min. Beam Height (in.)	I-Beam Width (in.)	Min. Radius Curve (in.)	Wheel Tread Diameter (in.)	Net Weight (lb.)		
(lb.)	(Ton)						Plain	Geared	
Spark Resistant Models Only									
1000	1/2	HT-10-S	4	2 5/8 to 4 5/8	30	3 1/8	13	—	
2000	1	HT-20-S(G)	5	3 to 5	36	4	25	45	
4000	2	HT-40-S(G)	6	3 3/8 to 6	48	4 15/16	35	48	

* When ordering, specify "P" for Plain Trolley or "G" for Geared Trolley. Hand geared trolleys have standard hand chain drop of 9' - 6". Longer chain available.

NOTE: For complete dimensional data, refer to Coffing Dimensional Databook.

**RIGID
DESIGN,
EASILY
ADJUSTABLE**

MODEL
LT

AIR HOIST TROLLEYS



COFFING
HOISTS

LT Model Trolley

For CAH Model Air Hoists

COFFING Model LT - Rigid mount trolleys designed especially for use with lug suspended hoists. Trolleys mount directly to lug suspended hoists, forming integral trolley-hoist combinations.

CAPACITIES - Rated loads of 1/4 to 3 ton in plain and geared models.

PLAIN TROLLEY - For manual positioning of hoist and load—1/4 to 3 ton models.

GEARED TROLLEY - For more precise positioning of hoist and load. Geared trolleys have standard 9' 6" hand chain drop—1 to 3 ton models.

CONSTRUCTION - All steel construction for maximum strength. Wheels have hardened treads, ensuring long life, and operate on ball bearings for easy travel.

UNIQUE DESIGN - For lug suspension Coffing CAH air hoists.

LOW HEADROOM - Integral trolley-hoist combinations allows maximum hook travel.

OPTIONS - Spark resistant models available 3/8 to 2 ton. Heavy-duty trolleys available for lug mounting to all air hoist models.

LIFETIME WARRANTY



1/4 - 3 Ton

Made in USA

High Performance Lifting
COFFING[®]
HOISTS

● SPECIFICATIONS ●

Model LT Plain & Geared Trolleys

Capacity		Model Number *	Min. Beam Height (in.)	I-Beam Width (in.)	Min. Radius Curve (in.)	Wheel Tread Diameter (in.)	Net Weight (lb.)	
(lb.)	(Ton)						Plain	Geared
500 †	1/4	LT-05-P	4	2 5/8 to 4 5/8	30	3 1/8	15	—
1000 †	1/2	LT-10-P	4	2 5/8 to 4 5/8	30	3 1/8	15	—
2000 †	1	LT-20-P(G)	5	3 to 5	42	4	23	40
2000 †	1	LT-20-WP(G)	5	5 1/4 to 7 3/8	42	4	24	41
4000	2	LT-40-P(G)	6	3 3/8 to 6	48	4 15/16	43	57
4000	2	LT-40-WP(G)	6	6 1/8 to 8 7/8	48	4 15/16	44	58
6000	3	LT-60-P(G)	6	3 3/8 to 6	48	4 15/16	50	65
6000	3	LT-60-WP(G)	6	6 1/8 to 8 7/8	48	4 15/16	52	67
6000	3	LT-60-WFP(G)	6	9 to 11	48	4 15/16	54	68
Spark Resistant Models								
750	3/8	LT-07-S	4	2 5/8 to 4 5/8	30	3 1/8	15	—
1000	1/2	LT-10-S(G)	5	3 to 5	42	4	23	40
1500	3/4	LT-15-S(G)	5	3 to 5	42	4	23	40
2000	1	LT-20-S(G)	6	3 3/8 to 6	48	4 15/16	45	57
4000	2	LT-40-S(G)HD **	8	4 3/8 to 6 1/4	48	4	85	100

* When ordering, specify "P" for Plain Trolley or "G" for Geared Trolley. Hand geared trolleys have standard hand chain drop of 9' - 6". Longer chain available.

† Metric Rated Trolleys

** Heavy-Duty Model — wide flange options available — consult factory.

NOTE: For complete dimensional data, refer to Coffing Dimensional Databook.



MODEL AMT

**SMOOTH
CONTROL-
RIDING *on* AIR**



1/4 - 3 Ton

Made in USA

**COFFING®
HOISTS**

AMT Model Air Motor Trolley For CAH Model Air Hoists

COFFING Model AMT - Designed to operate with Coffing CAH air chain hoists for faster positioning of the hoist in a variety of lifting applications.

CAPACITIES - Rated loads from 1/4 to 3 ton.

SPEEDS - Variable up to 50 FPM 1/4 to 1 ton and up to 60 FPM 2 and 3 ton.

8-VANE MOTOR - Provides high torque, smooth starting, and excellent control.

EXTENDED SIDE PLATES - Steel frame side plates extend beyond wheels for end stop contact. Sideplates have tapped holes suitable for bracket attachments such as festooning arms or safety lugs.

WHEELS - Forged, heat-treated steel, with dual tread for use on Standard or wide flange beams. Wheel bearings are sealed, life-time-lubricated precision ball bearings.

CONTROLS - Pendant throttle control provides precise, controlled spotting and efficient load handling.

OPTIONS - Spark resistant models. Rated loads 3/8 - 2 ton. For areas where spark protection is required in hazardous environments. Same features apply to these models with the addition of spark resistant bronze wheels.

AIR SUPPLY - Consumption: 50 SCFM; Pressure: 90 PSI.

LIFETIME WARRANTY

● SPECIFICATIONS ●

Model AMT Air Powered Trolley

Capacity		Model Number	Traverse Speed (fpm)	Min. Beam Height (in.)	Flange Width			Min. Radius Curve (in.)	Wheel Tread Diameter (in.)	Net Weight (lb.)
(lb.)	(Ton)				Standard (in.)	First Extension (in.)	Second Extension (in.)			
500	1/4	AMT-0550	50	6	3 to 5	5 1/8 to 7 1/4	7 1/2 to 9 1/8	36	4	95
1000	1/2	AMT-1050	50	6	3 to 5	5 1/8 to 7 1/4	7 1/2 to 9 1/8	36	4	95
2000	1	AMT-2050	50	6	3 to 5	5 1/8 to 7 1/4	7 1/2 to 9 1/8	36	4	95
4000	2	AMT-4060	60	7	3 5/8 to 6	6 1/4 to 8 5/8	8 7/8 to 11 1/4	48	4	105
6000	3	AMT-6060	60	8	4 to 6 1/4	6 3/8 to 8 5/8	8 3/4 to 11	48	4	150
Spark Resistant Models										
750	3/8	AMT-0750-S	50	6	3 to 5	5 1/8 to 7 1/4	7 1/2 to 9 1/8	36	4	95
1000	1/2	AMT-1050-S	50	6	3 to 5	5 1/8 to 7 1/4	7 1/2 to 9 1/8	36	4	95
1500	3/4	AMT-1550-S	50	6	3 to 5	5 1/8 to 7 1/4	7 1/2 to 9 1/8	36	4	95
2000	1	AMT-2060-S	60	7	3 5/8 to 6	6 1/4 to 8 5/8	8 7/8 to 11 1/4	48	4	105
4000	2	AMT-4060-S	60	8	4 to 6 1/4	6 3/8 to 8 5/8	8 3/4 to 11	48	4	150

NOTE: Equipped with 7-foot pendant control hose. **NOTE:** For complete dimensional data, refer to Coffing Dimensional Databook.



The IDEAL WORKSTATION HOIST

MODEL TMM-140



TMM-140 Air Manipulator Hoist

COFFING TMM-140 Models - The ideal workstation hoist. Light-weight and portable, the unit weighs less than 20 pounds and operates at 100% (A5) duty cycle.

CAPACITY - Rated loads 300 lbs. / 140 kg.

SMOOTH OPERATION - Efficient rotary vane motor provides high uniform torque for quick response and smooth, quiet operation.

EASY TO USE - Handle-mounted pendant control for one-handed operation and load positioning.

VARIABLE SPEEDS - Precise and infinite speed control for accurate load spotting.

WIRE ROPE DESIGN - Self-winding galvanized lifting cable stores conveniently inside unit.

SUSPENSION - Swivel top and bottom hooks with safety latches standard, for portability and quick installation.

DISC BRAKE - Secures load and eliminates drift when pendant is released.

LIFETIME WARRANTY

NOTE: A 3/8" NPT air filter-regulator-lubricator is recommended for optimum operation. Spark resistant features are not available.



300 lb. / 140 kg.



Ideal Applications Include:

- Assembly Lines • Machine Shops • Cleaning and/or Dipping Operations
- Manufacturing Plants • Power Generating Stations • Shipping Departments
- Chemical Facilities • Fabricating Shops • Repetitive Lifting Applications
- Auto and Truck Repair • Handling Fixtures and Dies

● SPECIFICATIONS ●

TMM-140 Air Manipulator Hoists

Capacity		Model Number	Std. Lift (ft.)	Lift Speeds (fpm)				Air Consumption		Headroom (in.)	Housing Dimen. (in.)			Max Air Pres. (psi)	Net Wt. (lb.)
(lb.)	(kg)			Load (Up)	(Down)	No Load (Up)	(Down)	(m3 / min)	(ft3 / min)		D	W	L		
300	140	TMM-140A	6' 6"	36	59	49	39	0.6	21.2	22 3/4	7 2/3	7 7/8	23 3/4	70 - 95	18.7

Note: For complete dimensional data, refer to Coffing Dimensional Databook

How To Determine Your Air Hoist Requirements

Hoist Capacity

Determine the maximum load to be lifted. If the load falls between standard rated capacities, always select the higher capacity (i.e., for 4,300 lb. maximum load, use 6,000 lb., or 3-ton capacity hoist).

Hoist Lift

To determine the total lift required, measure the distance from the bottom of the beam to the lowest point on the floor to be reached and subtract the hoist headroom dimension shown in the specifications. The remaining distance is the lift required on the hoist. Always select a standard lift equal to or greater than the distance.

Duty Cycle

Air motors inherently are self-cooling during operations. Unlike an electric motor which heats during operation, air motors are suitable for unlimited "on-time" and unlimited "number of starts". Coffing® CAH model air hoists are desirable for duty cycles demanding 100% "on-time".

Explosive Atmosphere

Since air hoists operate on compressed air, there is no electrical arcing hazard to cause explosions in such areas as paint spraying and petrochemical facilities. For those hazardous atmosphere applications where resistance to friction sparks is vitally important, spark resistant models are available. Spark resistant features include: bronze alloy hooks, stainless steel hook latches, non-magnetic, stainless steel load chain; modified load sprocket, guide and stripper arrangement; and stainless steel or anodized aluminum lower blocks. Since stainless steel load chain is of lower strength than standard, CAH spark resistant models are de-rated in capacity.

Control

Normally, air hoists lift loads at a faster rate of speed than electric hoists. Additionally, air hoists have variable speed control to lift loads from creep speed to full speed. Applications requiring variable speed lifting for precise load spotting and smooth starting action should employ an air hoist. Also to be considered are pull cord or pendant throttle as the means for operator control of the hoist and load.

Hoist Suspension

Coffing® CAH model air hoists can be offered in a wide variety of suspension options. Hook type suspension offer maximum versatility and portability in most environments. Lug suspensions save headroom and can be used with rigid mount trolleys or in permanently mounted locations.

Trolley Type

There are three standard trolley types that can be used to suspend Coffing® CAH model air hoists.

Push Trolley — Recommended for light capacities up to 2-tons and lifts below 20 feet. Most economical.

Hand Geared Trolley — Offers precise control for load spotting. Most favorable for higher capacities, short monorails, and where lifts exceed 20 feet.

Air Motor Driven Trolley — Most widely used method of suspension, particularly 2-ton capacity and above. Often a necessity where long monorails are used.

Special Note

The installation of every air hoist must include a filter and lubricator in the air line. An air regulator is also recommended.



FILTER-LUBRICATOR UNITS

Air hoists must have a supply of clean, lubricated air for their operation. A filter and lubricator must be installed in the air supply line, as close as practical to the hoist. The recommended operating air pressure for all capacities of COFFING® air hoists is 90 PSI. When air line pressure exceeds 115 PSI, it is required that a pressure regulator be provided in the supply line to maintain proper pressure.

Filter-Lubricator Units

Model Number	Inlet / Outlet Size (in.)	Bowl Size	Shipping Weight (lb.)
C902960	3/8	11 oz.	8
C902961	1/2	11 oz.	8
C902962	3/4	24 oz.	12
C902963	1	24 oz.	12

Filter-Regulator-Lubricator Units

Model Number	Inlet / Outlet Size (in.)	Bowl Size	Shipping Weight (lb.)
C902966	3/8	11 oz.	14
C902967	1/2	11 oz.	14
C902968	3/4	24 oz.	18
C902969	1	24 oz.	18



CHAIN CONTAINERS

Chain containers provide an ideal means for eliminating hanging tail chains. They are easily installed and accept the chain in such a way that chains tend not to kink or twist. State codes often specify the use of a chain container with each hoist.

Chain Containers for CAH-Small Frame Air Hoists

Model Number	Chain Type	Max. Lift (ft.)		Shipping Weight (lb.)
		1/4, 3/8, 1/2 Ton	3/4, 1 Ton	
C902631	Link Chain	25	12	4 1/2
C902635	Link Chain	45	22	9
C902634	Link Chain	25	12	5
C902636	Spark Resistant	45	22	10
C902632	Roller Chain	15	—	6 1/2
C902633	Roller Chain	30	15	11

Chain Containers for CAH-Large Frame Air Hoists

Model Number		Max. Lift (ft.)			Shipping Weight (lb.)
Standard Models	Spark Resistant Models	1 Ton	2 Ton	3 Ton	
C905434	C905444	15	do not use	do not use	4
C905435	C905445	30	15	10	8
C905436	C905446	45	22	15	10
C905437	C905447	60	30	20	14
C905438	C905448	75	37	25	15
C905439	C905449	90	45	30	16



AIR HOSE ASSEMBLY

Complete Air Hose Assembly requires ordering Air Supply Hose and Fittings.

Air Supply Hose

Model Number	I.D. (in.)	O.D. (in.)	Braid	Max. PSI	Width (ft.)
C901610	1/2	15/16	1	200	0.33
C901611	3/4	1 1/4	2	225	0.52
C901612	1	1 1/2	3	200	0.65

Fittings*

Male Swivel at One End-Standard Male at Opposite End

Model Number	Hose I.D. in.	Thread Size M-NPT
C901614	1/2	3/8
C901615	3/4	3/4
C901616	1	3/4

* Fittings installed on adjacent hose

Fittings w/ Quick Disconnect*

Quick Disconnect on One End-Standard Male at opposite end

Model Number	Hose I.D. in.	Thread Size M-NPT
C901618	1/2	3/8
C901619	3/4	3/4
C901620	1	3/4

* Fittings installed on adjacent hose

AIR HOSE TROLLEYS

Model No. C254

These trolleys are used to support air hose and are installed on the same track as a hoist. Hose clamp swivels and will fit 5/8 to 1 1/2 inch diameter hoses.





ACCESSORIES

AIR POWERED HOISTS

RECOIL AIR HOSE With Fittings

For application where air hose trolleys with looped hose is impractical: coil type self-storing hose is recommended.

Self Storing Air Hose With Fittings

Model Number	Hose Size (I.D. in.)	x	Working Length (ft.)	Fittings Each End
C901621	1/2"	x	15'	3/8 NPTF Male Swivel Fittings
C901622	1/2"	x	25'	3/8 NPTF Male Swivel Fittings
C901624	3/4"	x	15'	3/4 NPTF Male Swivel Fittings
C901625	3/4"	x	25'	3/4 NPTF Male Swivel Fittings
C901626	3/4"	x	50'	3/4 NPTF Male Swivel Fittings

Nylon Coated Cable w/ Eyebolt Fittings Each End For Supporting Recoil Air Hose (Supports by Others)

Model Number	Length (ft.)
C901629	25'
C901630	50'



AIR HOSE REELS

Whichever hose-use problem you may have – on the production line, in the shipping area or in maintenance – these automatic retracting reels can provide the solution. Easy-set mounting lugs and adjustable 4-roller guides allow variable mounting for ceiling, wall, bench or trucks. An instant-action ratchet lock engages when hose travel stops, disengages with a slight pull. Other features include the "Safe-to-Change" spring motor which is self-contained for safe handling and all-steel construction for maximum reliability. Hose and ball stop are included. Pivot Base is optional.

Hose Data			Reel Model Number	NPTF Fittings E' & F	Weight Complete (lb.)	340° Base (OPT)
I.D. (in.)	Length (ft.)	Max PSI				
3/8	25	200	C913207	0.38 - 18	36	913083
3/8	35	200	C913208	0.38 - 18	40	913083
3/8	50	200	C913209	0.38 - 18	72	913098
1/2	25	200	C913210	0.50 - 14	70	913098
1/2	35	200	C913211	0.50 - 14	74	913098
1/2	50	200	C913212	0.50 - 14	79	913098
3/4	20	300	C913201	0.75 - 0.75	144	913206
3/4	30	300	C913202	0.75 - 0.75	149	913206
1	20	300	C913203	1.00 - 1.00	148	913206
1	30	300	C913204	1.00 - 1.00	159	913206



FESTOONING SYSTEMS FOR AIR SUPPLY HOSE

Systems include (note numerical key in illustration below): (1) 2 End Clamp Assemblies; (2) 1 Hardware Kit consisting of 2 eye-bolts, 5 clamps and 1 ball stop; (3) Intermediate Carriers—see specified quantity in last column of chart below; (4) Nylon Covered Wire Rope per required length.

Hose Systems (from 0.91" to 1.25" O.D.)

Model System Number	A Working Travel (ft.)	B Loop Depth (ft.)	C Overall Length (ft.)	Max. Combined Cable Weight (lb. / ft.)	D Storage Space (ft.)	Clamp Distance (ft.)	No. of Carriers (Item 3)
C901601	16	3	18.5	1.31	0.84	6.87	2
	21	4	23.5	1.01	0.84	8.87	2
C901602	28	3	31.1	1.31	1.40	6.87	4
	37	4	40.1	1.01	1.40	8.87	4
C901603	40	3	43.6	1.31	1.97	6.87	6
	52	4	55.6	1.01	1.97	8.87	6

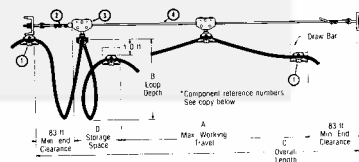

OTHER AVAILABLE AIR HOIST ACCESSORIES

Bullard Hooks - All hoists are furnished as standard with hooks equipped with hook latches. Bullard Hooks with a rugged cast swing gate locking member that provides greater assurance of load containment are available at additional cost.

Redundant Support - Hoist suspension redundant support for the CAH-Small Frame hoist is available for additional cost. This redundant support features a cable that inserts through the hoist frame and around initial support.

Pendant Throttle Conversion Kit - Kit for converting the pull cord CAH-Small Frame COFFING® Air Hoist to pendant throttle operation has a standard 6-foot pendant hose assembly. Longer hose assemblies available. Order Model No. C2269. Shipping weight is 8 pounds.

**STAMPED
STEEL-
IDEAL for
CONSTRUCTION**

MODEL
LHH



LHH Hand Chain Hoist

COFFING LHH Models - Stamped steel hand chain hoists are an excellent low cost option in the Coffing line. The compact, lightweight design is ideal for construction and contractor applications where portability and easy rigging are critical.

CAPACITIES & LIFT - Rated loads from 1/2 to 20 Tons in stock with standard lifts of 10, 15, and 20 feet. Standard hand chain drop is 2-feet less than lift. Other lifts, hand chain drops and 25 - 50 Ton models available — consult factory.

COMPACT and LIGHTWEIGHT - Designed for portability and easy installation. Compact gear housing provides low headroom.

EASY TO OPERATE - Lubricated bearings and bushings, bearing-mounted pinions, and heat-treated spur gearing ensure smooth and efficient operation with minimal effort.

SAFETY & LOAD CONTROL - Mechanical load brake engages instantly for precise load holding and positioning. 360° swivel hooks with safety latches for positive load engagement.

DURABLE - Through hardened load chain provides added strength and wear resistance for greater chain life. Stamped steel housing withstands rugged conditions.

EASY TO MAINTAIN - Designed for easy inspection and maintenance. Hoist can be dismantled easily with simple hand tools.

METRIC RATED

LIFETIME WARRANTY

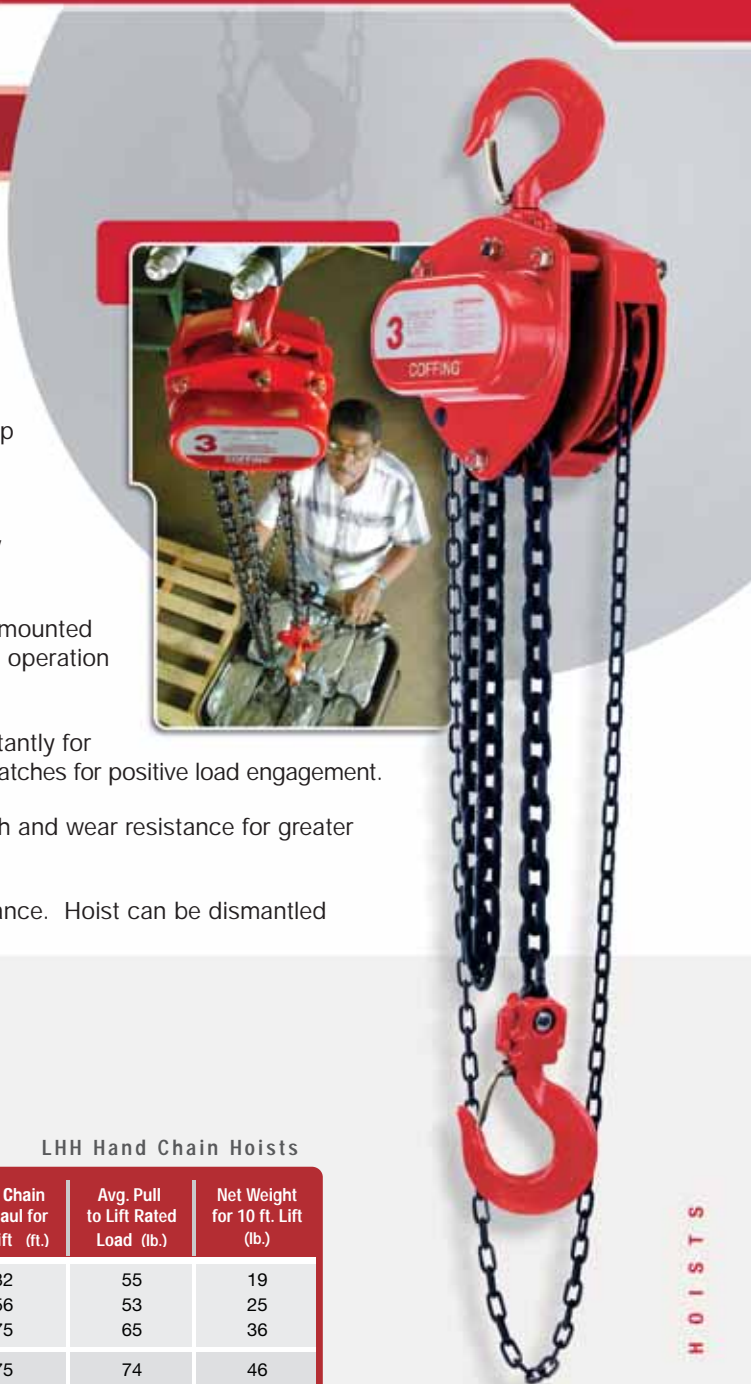

1/2 - 50 Ton

● SPECIFICATIONS ●

LHH Hand Chain Hoists

Capacity		Model Number	Lifts ** (ft.)	Strands of Load Chain (Reeving)	Headroom (in.)	Hand Chain Overhaul for 1 ft. Lift (ft.)	Avg. Pull to Lift Rated Load (lb.)	Net Weight for 10 ft. Lift (lb.)
(lb.)	(Ton)							
1000	1/2	LHH-1/2	10/15/20	1	10 1/4	32	55	19
2000	1	LHH-1	10/15/20	1	11 13/16	56	53	25
3000	1 1/2	LHH-1 1/2	10/15/20	1	13 9/16	75	65	36
4000	2	LHH-2	10/15/20	1	15	75	74	46
6000	3	LHH-3	10/15/20	1	17 1/8	95	84	66
10000	5	LHH-5	10/15/20	3	22 5/8	203	79	75
16000	8	LHH-8	10/20	3	32 1/2	312.5	77	158
20000	10	LHH-10	10/20	3	32 1/2	312.5	95	158
24000	12	LHH-12	10/20	5	50 5/8	526	84	328
30000	15	LHH-15	10/20	5	50 5/8	526	103	328
40000	20	LHH-20	10/20	6	52 3/8	312.5 x 2 †	99 x 2 †	535
50000	25*	LHH-25	10	8	52 3/8	416.7 x 2 †	97 x 2 †	680
60000	30*	LHH-30	10	10	65	526.3 x 2 †	104 x 2 †	945
80000	40*	LHH-40	10	14	73 5/16	714.3 x 2 †	101 x 2 †	1400
100000	50*	LHH-50	10	20	77 5/8	1000 x 2 †	104 x 2 †	1840

* 25, 30, 40 and 50 Ton models available by special order — consult factory.

** Standard lifts shown. Other lifts available — consult factory.

† LHH-20 through LHH-50 models have two hand chains.

Note: For complete dimensional data, refer to Coffing Dimensional Databook



MODEL
CA/CB

**PROVEN
INDUSTRIAL
PERFORMANCE**

CA & CB Hand Chain Hoists



COFFING CA & CB Models - Hand chain hoists set the standard for performance and durability. The CB has exclusive right angle Superoid® gearing (see facing page) which provides smooth chain travel and requires little maintenance. The CB is ideal for industrial lifting applications.

CAPACITIES & LIFT - Rated loads from 1/2 to 12 Tons. Standard 8-foot lift and 6-foot hand chain drop. Other lifts and hand chain drops available.

GOVERNMENT APPROVED - All CB models except CA-1/2 meet MIL-H-904 Class 2 requirements, Type C, Style 1 or 2.

DURABLE - Impact-resistant, permanent mold aluminum alloy housing provides extra strength and long service life.

EASY INSPECTION AND MAINTENANCE - Easily dismantled with simple hand tools for routine inspection and maintenance.

OPTIONAL CAPACITY LIMITER - Provided when specified at time of order at no extra charge (see facing page).

LOAD CONTROL - Fully enclosed, self-adjusting, friction-type screw and disc load brake ensures positive load control.

TWIN HOOK (TH Models) - Available for 1/2 to 3 Ton models. Useful for lifting long, bulky loads. Standard 3-foot space between hooks - for other spacing, consult factory. See Fig. 1

EXTENDED HAND WHEEL (EHW Models) - Available for 1 1/2 to 3 Ton models. Useful for dipping applications or other situations where hoist must be operated from a distance. Standard 3-foot extension — for other lengths, consult factory. See Fig. 2

OPTIONS - Bullard hooks, plated hooks, plated chain, stainless steel chain, spark-resistant features, and top clevis connection available - consult factory. Chain containers available, see page 53.

LIFETIME WARRANTY

● SPECIFICATIONS ●

CA & CB Hand Chain Hoists

Capacity		Model †	Capacity Limiter Model †	Strands of Load Chain (Reeving)	Headroom (in.)	Hand Chain Overhaul for 1 ft. Lift (ft.)	Avg. Pull to Lift Rated Load (lb.)	Net Weight (lb.)
(lb.)	(Ton)							
1000	1/2	CA-1/2*	CA-1/2-CL*	1	13 1/4	18	58	22
2000	1	CB-1	CB-1-CL	1	13 3/8	38	58	38
3000	1 1/2	CB-1 1/2	CB-1 1/2-CL	1	18 1/2	58	62	58
4000	2	CB-2	CB-2-CL	1	18 1/2	58	83	58
6000	3	CB-3	CB-3-CL	1	21 1/2	85	91	78
8000	4	CB-4	CB-4-CL	2	25 1/4	116	85	98
10000	5	CB-5	CB-5-CL	3	26 3/4	174	72	127
12000	6	CB-6	CB-6-CL	3	26 3/4	174	87	127
16000	8	CB-8	CB-8-CL	4	28 1/2	232	90	160
20000	10	CB-10	CB-10-CL	4	31	340	83	212
24000	12	CB-12	CB-12-CL	4	31	340	100	212

* Spur gear model

† Specify TH for twin hook model or EHW for extended hand wheel model (ex. TH-1 or EHW-3)

Note:
For complete dimensional data, refer to Coffing Dimensional Databook

HAND CHAIN HOISTS for TROLLEY APPLICATIONS

MODEL CTH



CTH - Trolley Mounted Suspension

COFFING CTH Models - Featuring a CA or CB hoist integrally mounted to a CT trolley. The CTH is ideal for industrial lifting applications which require a trolley mounted hoist for horizontal movement of the load.

CAPACITIES & LIFT - Rated loads from 1/2 to 6 Tons in plain or geared trolley models. Standard 8-foot lift and 6-foot hand chain drop, with other lifts and hand chain drops available.

REDUCED HEADROOM - Lug-mounted trolley hoist design.

HOIST FEATURES - Please refer to CA and CB information on previous page.

OPTIONS - Capacity limiter available - provided when specified at time of order at no extra charge. Special trolley wheels, spark resistant features, and track clamps available — *consult factory*.



● SPECIFICATIONS ●

CTH Trolley Mounted Hoists

Capacity		Model Number	Headroom (in.)	Hand Chain Overhaul for 1 ft. Lift (ft.)	Avg. Pull to Lift Rated Load (lb.)	Std. Beam Height (in.)	Minimum Radius Curve (in.)	Net Weight	
(lb.)	(Tons)							Plain (lb.)	Geared (lb.)
1000	1/2	CTH-1/2-P(G)*	14	18	58	6 - 18	21	94	101
2000	1	CTH-1-P(G)	14 3/8	38	58	6 - 18	21	98	150
3000	1 1/2	CTH-1 1/2-P(G)	18 3/4	58	62	6 - 18	21	152	159
4000	2	CTH-2-P(G)	18 3/4	58	83	6 - 18	21	152	159
6000	3	CTH-3-P(G)	20	85	91	6 - 18	21	167	174
8000	4	CTH-4-P(G)	27 1/6	116	85	6 - 18	21	167	174
10000	5	CTH-5-P(G)	27 3/4	174	72	6 - 18	48	195	202
12000	6	CTH-6-P(G)	27 3/4	174	87	6 - 18	48	195	202

NOTE: When ordering, specify "P" for plain trolley or "G" for geared trolley

* Spur gear model

** For Straight track only. Articulated model for 48 inch minimum radius curve track available. For wide flange and patented track applications, consult factory.

1/2 - 6 Ton

Made in USA

FEATURES

CA, CB, TH, EHW & AT Models

Superoid® Gearing

Coffing's exclusive Superoid® gear transmission provides greater strength and durability with fewer wearing parts. This unique right angle gear drive involves only two rugged gears and engages four teeth at all times, providing smooth lifting power and spreading wear to decrease the need for maintenance.



Capacity Limiter

Coffing's optional capacity limiter protects the operator, the load, and the hoist. Under severe overload conditions, the capacity limiter's clutch assembly automatically disengages the handwheel to prevent lifting of a dangerous overload. Removing the overload automatically restores the lifting capacity of the hoist. The capacity limiter is provided when specified at no extra charge.





MODEL
AT

**LOW
HEADROOM —
GOVERNMENT
APPROVED**

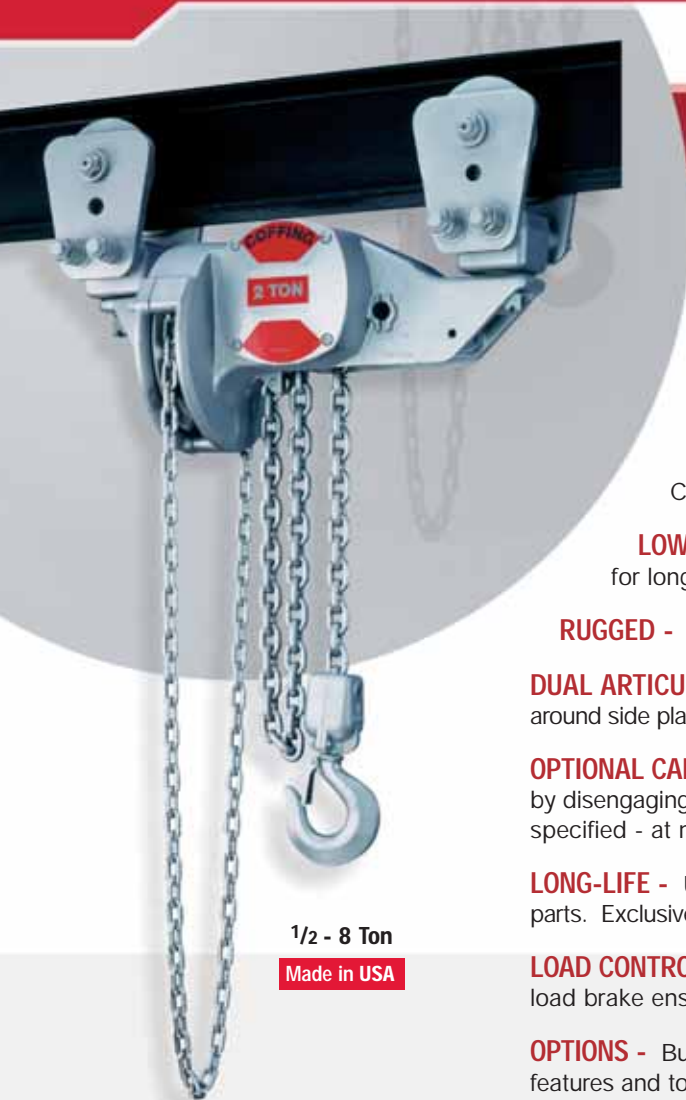

1/2 - 8 Ton

Made in USA

AT Model Hand Chain Hoists

COFFING AT Model - An Army-type trolley hoist. The AT is ideal for industrial lifting applications which require low headroom for longer hook travel.

CAPACITIES & LIFT - Rated loads from 1/2 to 8 Tons in plain or geared trolley models. Standard 8-foot lift with 6-foot hand chain drop. Other lifts and hand chain drops available.

GOVERNMENT APPROVED - All models meet MIL-H-904 Class 1 and Class 2 requirements, Type D or E, Style 1 or 2.

LOW HEADROOM - Army-type trolley hoist design provides excellent headroom for longer hook travel.

RUGGED - Hoist housing and frame made from iron material.

DUAL ARTICULATING TROLLEYS - Designed to travel tight radius curved beams. Wrap-around side plates (*not shown*) increase operator safety and act as bumpers to protect wheels.

OPTIONAL CAPACITY LIMITER - Clutch assembly prevents lifting of damaging overloads by disengaging the hand wheel, protecting both the operator and the load. Provided when specified - at no extra charge.

LONG-LIFE - Unique right angle drive provides superior performance with fewer wearing parts. Exclusive Superoid® gearing engages more gear teeth to support the load (*see page 47*).

LOAD CONTROL - Fully enclosed, self-adjusting, friction-type screw and dual disc Weston load brake ensures positive load control.

OPTIONS - Bullard hooks, plated hooks, plated chain, stainless steel chain, spark-resistant features and top clevis connection available — *consult factory*. Chain containers available, *see page 53*.

LIFETIME WARRANTY

● **SPECIFICATIONS** ●

AT Hand Chain Hoists

Capacity		Model Number	Headroom (in.)	Strands of Load Chain	Hand Chain Overhaul for 1 ft. Lift (ft.)	Avg. Pull to Lift Rated Load (lb.)	Std. Beam Height (in.)	Minimum Radius Curve (in.)	Net Weight	
(lb.)	(Ton)								Plain (lb.)	Geared (lb.)
1000	1/2	AT-1/2-P(G)	10 3/8	1	24	39	6 - 18	21	94	101
2000	1	AT-1-P(G)	11	2	48	41	6 - 18	21	98	150
3000	1 1/2	AT-1 1/2-P(G)	14 5/8	1	58	62	6 - 18	21	152	159
4000	2	AT-2-P(G)	14 5/8	1	58	83	6 - 18	21	152	159
6000	3	AT-3-P(G)	19 1/8	2	116	64	6 - 18	21	167	174
8000	4	AT-4-P(G)	19 1/8	2	116	85	6 - 18	21	167	174
10000	5	AT-5-P(G)	21 5/16	3	174	72	6 - 18	48	195	202
12000	6	AT-6-P(G)	21 5/16	3	174	87	6 - 18	48	195	202
16000	8	AT-8-P(G)	20 3/4	4	232	90	6 - 18	48	241	248

Note: When ordering, specify "P" for plain trolley or "G" for geared trolley.
Note: For complete dimensional data, refer to Coffing Dimensional Databook

**CLOSE
HEADROOM —
SWIVEL TRUCK
MANEUVERABILITY**

MODEL
YLHA



YLHA Model Hand Chain Hoist

COFFING YLHA MODEL - A heavy duty, compact, swivel truck trolley hoist designed for true low headroom capabilities. It is available in plain or hand geared versions and will negotiate very tight radius curves.

CAPACITIES & LIFT - Rated loads from 1/4 to 6 Tons.

DUAL ARTICULATING TROLLEYS - Travel easily on curved beams.

EXTREMELY LOW HEADROOM - Provides increased hook travel and maneuverability in tight places.

STEEL CONSTRUCTION - Hoist and trolley are built for maximum strength and long life.

GEAR TRAIN - Heat treated, alloy steel, planetary hoist gearing.

LOAD CONTROL - Weston type load brake assures positive and efficient load control with minimal maintenance.

LOAD SPROCKET - Precision formed, cast steel pockets. Load sprocket can be reversed when a new chain is installed, providing extended sprocket life.

OPTIONS - Wrap-around side plates available.

LIFETIME WARRANTY



● SPECIFICATIONS ●

YLHA Hand Chain Hoists

Capacity		Model Number	Headroom (in.)	Strands of Load Chain	Hand Chain Overhaul for 1 ft. Lift (ft.)	Avg. Pull to Lift Rated Load (lb.)	Min. Beam Size †	Minimum Radius Curve (in.)	Net Weight	
(lb.)	(Ton)								Plain (lb.)	Geared (lb.)
500	1/4	YLHA-1/4P(G)*	6 3/16	2	33	17	S5" x 10.0#	21	127	144
1000	1/2	YLHA-1/2P(G)*	6 3/16	2	33	35	S5" x 10.0#	21	127	144
2000	1	YLHA-1P(G)*	6 3/16	2	33	70	S5" x 10.0#	21	127	144
3000	1 1/2	YLHA-1 1/2P(G)*	6 3/4	2	66	57	S6" x 12.5#	30	245	267
4000	2	YLHA-2P(G)*	6 3/4	2	66	76	S6" x 12.5#	30	251	270
6000	3	YLHA-3P(G)*	8 1/4	2	170	42	S8" x 18.4#	42	345	375
8000	4	YLHA-4P(G)*	9 1/4	2	170	58	S8" x 18.4#	42	350	380
10000	5	YLHA-5P(G)*	9 15/16	2	170	73	S8" x 18.4#	48	466	496
12000	6	YLHA-6P(G)*	9 15/16	2	170	90	S8" x 18.4#	48	466	496

† This trolley hoist is not adjustable to varying size beams. Each unit is custom built to customer's specific beam size. Minimum beam size listed is for wheel clearance only. Exact beam specifications must be furnished - height, type and flange width and radius curve(s).

These trolley hoists can be built to fit most wide flange beams as well as patented monorail track, wither straight or with curves - apply to factory with specific application details.

Special features such as spark resistant units, units meeting military specifications, units with chain containers and track clamps can also be furnished - apply to factory with specific engineered requirements.

MODEL
CBT**SMOOTH
ROLLING-
An ECONOMICAL
CHOICE**

1/4 - 5 Ton

CBT Plain & Geared Trolleys

COFFING CBT Model - Available in plain and geared models, the CBT is the economical choice for most applications. The trolley features steel wrap around side plates, dual tread wheels and lifetime lubricated shielded ball bearings. All the CBTs' features combine to ensure you a trolley that is smooth rolling, versatile and reliable.

CAPACITIES - Rated loads from 1/4 to 5 Ton (*Metric Rated*). In plain and geared models.

ECONOMICAL - Excellent low cost choice for manual and powered hoists.

RUGGED - Designed to provide superior performance and long, efficient service.

LOW ROLLING EFFORT - Geared models have standard 6-foot hand chain drop. Other hand chain drops available.

UNIVERSAL HANGING CLEVIS - Accepts most hook mounted hoists.

ADJUSTABLE - Trolley easily adjusts to fit any beam flange within range of adjustment, up to an 8.7" flange width.

WRAP-AROUND SIDE PLATES - Lugs provide additional security to increase operator safety and act as bumpers to protect wheels.

DUAL TREAD WHEELS - Will fit either tapered or flat beam flange within range of adjustment. Wheels include permanently lubricated, shielded ball bearings for long life and low maintenance.

LIFETIME WARRANTY

COFFING®
HOISTS

● SPECIFICATIONS ●

CBT Plain & Geared Trolleys

Capacity *		Model Number **	Beam Height (in.)	I-Beam Width (in.)	Minimum Radius Curve (in.)	Wheel Tread Diameter (in.)	Net Weight (lb.)
(lb.)	(Ton)						
500	1/4	CBTP-0025	4 - 24	2.0 - 8.7	27	2.36	19
1000	1/2	CBTP-0050	4 - 24	2.0 - 8.7	27	2.36	19
2000	1	CBTP(G)-0100	5 - 24	2.3 - 8.7	36	2.36	26
3000	1 1/2	CBTP(G)-0150	6 - 24	2.3 - 8.7	45	3.15	46
4000	2	CBTP(G)-0200	6 - 24	2.3 - 8.7	45	3.15	46
6000	3	CBTP(G)-0300	8 - 24	3.0 - 8.7	55	4.41	86
10000	5	CBTP(G)-0500	10 - 24	3.5 - 8.7	70	4.92	130

* Metric Rated

** When ordering, specify "P" for plain trolley or "G" for geared trolley.

Note: For complete dimensional data, refer to Coffing Dimensional Databook



**SUPERIOR
PERFORMANCE,
MINIMAL
EFFORT**

MODEL
CTA

CTA Plain & Geared Trolleys

COFFING CTA Model - Featuring enhanced design, and available in plain and geared models which can be modified to fit a wide range of beam sizes and styles. The CTA is designed to provide easy operation and superior performance in industrial lifting applications.

CAPACITIES - Rated loads from 1/4 to 5 tons in plain and geared models. Geared trolleys have standard 6-foot hand chain drop. Other hand chain drops available.

RUGGED - Designed to provide superior performance and long, efficient service.

EASY OPERATION - Lowest rolling effort in the Coffing trolley line.

UNIVERSAL MOUNTING - Clevis accepts all Coffing hook-mounted hoists, or lug-mounted hoists attached directly to load pins.

INCREASED ADJUSTABLE - Trolley easily conforms to any beam flange within range of adjustment. For larger flange width, please consult factory.

WRAP-AROUND SIDE PLATES - Lugs provide additional security for operator and act as bumpers to protect wheels.

DUAL TREAD WHEELS - Fully machined wheels fit any tapered or flat flanged beams within range of adjustment. Wheels include permanently lubricated, shielded ball bearings for long life and low maintenance.

OPTIONS - Spark resistant and corrosion resistant wheels available. Track clamps available on 1/4 to 4 ton models.

LIFETIME WARRANTY



1/4 - 5 Ton
Made in USA

● SPECIFICATIONS ●

CTA Plain & Geared Trolleys

Capacity		Model Number *	Beam Height (in.)	I-Beam Width (in.)	Minimum Radius Curve (in.)	Net Weight	
(lb.)	(Ton)					Plain (lb.)	Geared (lb.)
500	1/4	CTA-05P(G)	6 - 18	3.33 - 7.00	48	46	52
1000	1/2	CTA-10P(G)	6 - 18	3.33 - 7.00	48	46	52
2000	1	CTA-20P(G)	6 - 18	3.33 - 7.00	48	46	52
4000	2	CTA-40P(G)	6 - 18	3.33 - 7.00	48	46	52
6000	3	CTA-60P(G)	6 - 18	3.33 - 7.00	48	46	522
8000	4	CTA-80P(G)†	6 - 18	3.33 - 7.00	**	125	130
10000	5	CTA-100P(G)†	6 - 18	3.33 - 7.00	**	125	130

* When ordering, specify "P" for plain trolley or "G" for geared trolley.
 ** Standard model for straight track only. Articulating model for 4-foot minimum radius curve available - Consult Factory

† Eight-wheel trolley design reduces beam flange stress.
Note: For complete dimensional data, refer to Coffing Dimensional Databook



MODEL
CYA

**HEAVY DUTY,
PLAIN or GEARED-
INDUSTRIAL
GRADE**

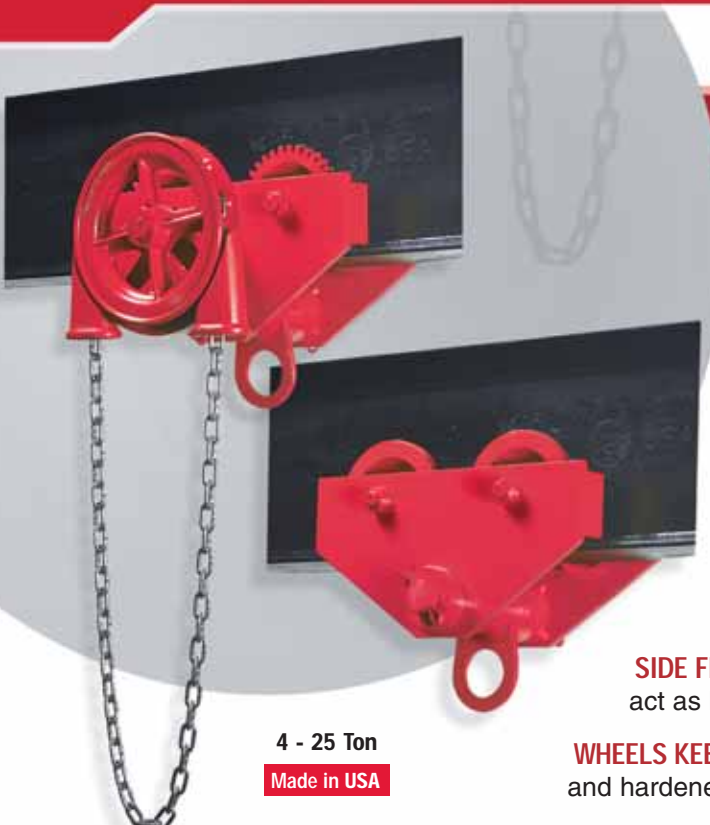

4 - 25 Ton

Made in USA

CYA Plain & Geared Trolleys

COFFING CYA Trolleys - Designed for heavy duty service with fully sealed, precision bearings, heavy-duty side plates, and machined wheel tread provide superior performance and long life with minimal maintenance.

CAPACITIES - Available in capacities ranging from 4 through 25 ton; with 30, 40 and 50 ton trolleys available as tandem construction.

DUAL TREAD - 4 through 12 ton capacity trolleys have dual tread wheels for standard and wide flange beams.

BEARINGS - Trolleys are equipped with eight sealed, Timken tapered roller bearings and grease fittings.

SIDE FRAMES - Heavy rolled steel frames extend beyond the wheels to act as bumpers.

WHEELS KEEP ON ROLLING - Trolley wheels are machined from cast iron alloy and hardened for high strength and long life.

SWINGING CHAIN GUIDE - Geared versions have fully machined track wheel gears and incorporate a swinging chain guide, which keeps the hand chain aligned and free from jamming.

REQUIREMENTS - Consult factory for additional beam sizes and patented track applications.

LIFETIME WARRANTY

COFFING®
HOISTS

● SPECIFICATIONS ●

CYA Plain & Geared Trolleys

Capacity		Model Number *	Beam Height (in.)	I-Beam Width (in.)	Minimum Radius Curve (in.) **	Net Weight	
(lb.)	(Ton)					Plain (lb.)	Geared (lb.)
8000	4	CYA-80P(G)	8 - 24	4.00 - 7.00	36	155	184
10000	5	CYA-100P(G)	8 - 24	4.00 - 7.00	36	160	188
12000	6	CYA-120P(G)	8 - 24	4.00 - 7.00	36	160	188
16000	8	CYA-160P(G)	10 - 24	4.63 - 8.00	60	300	347
20000	10	CYA-200P(G)	10 - 24	4.63 - 8.00	60	310	360
24000	12	CYA-240P(G)	10 - 24	4.63 - 8.00	60	310	360
32000	16	CYA-320P(G)	18 - 24	6.00 - 8.00	96	800	895
40000	20	CYA-400P(G)	18 - 24	6.00 - 8.00	96	845	955
50000	25	CYA-500P(G)	18 - 24	6.00 - 8.00	120	1045	1200

* When ordering, specify "P" for plain trolley or "G" for geared trolley.

† Weight less hand chain

** Specify curve on order. Wheels are modified to negotiate curves.

For wide flange beam adaptation, patented track or for beams larger than standard - consult factory.

8 ft. standard hand chain drop on geared trolley.

Note: For complete dimensional data, refer to Coffing Dimensional Databook



MODEL
VT-A

MODEL
BC

**CHAIN
CONTAINERS**
HAND CHAIN HOISTS

VT-A Push Type Trolley

COFFING VT-A Trolleys - A versatile, push-type, industrial grade hook mount trolley. Incorporating universal wheel tread design, the VT-A is ideal for use on a variety of American Standard Beams, wide flange beams and patented track applications.

CAPACITIES - Rated loads from 1/4 -3 Ton.

UNIQUE SIDE FRAME / LOAD BAR DESIGN - "Dial Fit" adjusting collar reduces installation time from 40 minutes to less than 4 minutes.

SHIELDED DOUBLE ROW BALL BEARINGS - Smooth rolling for longer life and greater efficiency.

NEGOTIATES SMALL RADIUS CURVES - 7 in. on 1 Ton capacity.

LIFETIME WARRANTY



1/4 - 5 Ton

Made in USA

• SPECIFICATIONS •

VT-A Trolleys

Capacity		Model Number	Adj. for Standard S-Beams		Tread Diameter (in.)	Minimum Radius Curve (in.)	Net Weight (lb.)	Shipping Weight (lb.)
(lb.)	(Ton)		Depth of Beam (in.)	Flange Width (in.)				
500	1/4	VT-05-A	4 - 12	2 5/8 - 5 1/16	2 3/4	7	9	10
1000	1/2	VT-10-A	4 - 12	2 5/8 - 5 1/16	2 3/4	7	9	10
2000	1	VT-20-A	4 - 12	2 5/8 - 5 1/16	2 3/4	7	10	12
3000	1 1/2	VT-30-A	6 - 15	3 3/8 - 5 5/8	3 1/2	10	23	25
4000	2	VT-40-A	6 - 15	3 3/8 - 5 5/8	3 1/2	10	23	35
6000	3	VT-60-A	8 - 18	4 - 6 1/4	3 1/2	10	29	33

All capacities can be supplied for S-beams larger than listed and also for wide flange beams, rails or tracks with approximately equivalent flange widths.



BC Beam Clamps

COFFING BC Models - Ideal as an anchor for rigging operations (*vertical or horizontal*), as a hoisting anchor, or as a tool for positioning and holding beams for welding. The BC is recommended for commercial, construction, and industrial applications.

CAPACITIES - Rated loads from 1 -10 Ton.

REDUCED FLANGE STRESS - Special clamp jaw design distributes load away from flange edge.

ADJUSTABLE - Threaded mechanism fits securely on a wide range of flange widths and beam sizes.

LOW HEADROOM - Provided by built-in suspension bar.

LIFETIME WARRANTY

Capacity		Model Number	I-Beam Width (in.)	Weight (lb.)
(lb.)	(Ton)			
2000	1	BC-1	3 - 9	9
4000	2	BC-2	3 - 9	13
6000	3	BC-3	3.2 - 12.6	18
10000	5	BC-5	3.6 - 12.2	22
20000	10	BC-10	3.6 - 12.2	34

Chain Containers For CA, CB, CTH, TH, EHW, and AT Models*

Hoist Capacity	Lift	Hoist Models	Hoist Capacity	Lift	Hoist Models
1/2 Ton	0' - 26'	CA CTH 1/2	1 1/2 & 2 Ton	0' - 12'	CB, CTH TH, EHW & AT
	27' - 31'			13' - 22'	
	32' - 42'			23' - 35'	
1 Ton	43' - 54'	CB, CTH, TH & EHW	3 Ton	0' - 12'	
	0' - 20'			13' - 17'	
	21' - 25'			18' - 25'	
1 Ton	26' - 35'	4 Ton	4 Ton	0' - 6'	CB, CTH TH & EHW
	36' - 50'			7' - 11'	
				12' - 17'	

* Other lifts and capacities available. consult factory.



RATCHET LEVER HOISTS

Coffing engineers have developed a full line of ratchet lever hoists to meet all your rigging needs. Our models have a variety of features that make each one uniquely suited for your applications. Choose from a variety of housing materials, brake options, load limiter options, and lifts, as well as special features such as plated chain and hooks. We feel confident that you will find the ratchet lever hoist you need!



LSB-B Model (pg.55)
Free Chain Mechanism

The LSB-B models feature a one-handed free chaining mechanism which allows quick and easy take-up of slack chain. There is an unconditional lifetime warranty on the free chain knob.



MA Model (pg.58)
Five Seals

Efficient hoist performance is assured by keeping moisture, oils, chemicals, and dirt out of the brake mechanism. Neoprene seals on the (1) Handle cap, (2) Load pawl shaft, (3) Load sheave, (4) Cover plate, and (5) Gasket on the cover plate, provide protection under exposure conditions.



MAL Model (pg.58)
Overload Slip Clutch

The MAL slip clutch load limiting device protects the load, the operator, and the hoist by preventing the lifting of damaging overloads. The gradual slip mechanism prevents sudden, unexpected movement of the handle.



RA Model (pg.59)
Ratchet and Pawl Design

When using an RA model, one pawl is always engaged with the ratchet during lifting and lowering operations. Ratchet and pawl design is useful for applications where a mechanical load brake is not desirable.



G Series Model (pg.60)
Single-Locking Pawl

The G Series single-pawl hoist is ideal for all types of work where a full stroke of the handle is permitted. The single-pawl design provides faster operation and longer incremental lift than the double-pawl design.



G Series Model (pg.60)
Double-Locking Pawl

The G Series double-locking pawl hoist is preferable when working in close quarters where a full stroke of the handle is not permitted. The load can be raised or lowered with a half-stroke of the handle. Can be furnished on all models up to and including 3-ton capacity.

The **INDUSTRY'S EASIEST to OPERATE** RATCHET LEVER HOIST

MODEL **LSB-B**



LSB-B Ratchet Lever Hoist

Coffing LSB-B Models are available with optional Load Limiters. Also featuring through-hardened load chain, these stamped steel ratchet lever hoists are lightweight, durable and are ideal for construction and commercial applications. All LSB-B hoists are metric rated.

CAPACITIES & LIFT - Rated loads of 3/4, 1 1/2, 3 and 6 tons, with 5, 10, 15 and 20 foot standard lifts. *Other lifts available.*

OPTIONAL LOAD LIMITER - Load Limiter alerts operator of a possible overload by allowing the handle to rotate without lifting the higher-than capacity load. The load limiter can be field-installed.

RUGGED AND LIGHTWEIGHT - Impact resistant, stamped steel housing withstands rigorous use. Compact design is portable and easy to rig.

LOW HANDLE EFFORT - Double reduction gearing and short, cushioned-grip handle provide easy operation with minimal handle effort.

360° ROTATING HANDLE - Provides versatile rigging options when used in confined spaces.

EASY FREE CHAINING - State-of-the-art free wheeling mechanism allows quick and easy one-handed take-up and positioning of slack chain.

POSITIVE LOAD CONTROL - Enclosed screw-and-disc type load brake stays clean and dry for positive load positioning. Latches on hooks provide positive load engagement.

OPTIONS - Shipyard hook available for 1 1/2 ton & 3 ton models

LIFETIME WARRANTY



3/4 - 6 Ton

● **SPECIFICATIONS** ●

LSB-B Ratchet Lever Hoists

Capacity		Model Number	Lift (ft.) *	Strands of Load Chain	Minimum Dist. Between Hooks (in.)	Handle Length (in.)	Average Handle Effort (lb.)	Net Weight (lb.)
(lb.)	(Ton)							
1500	3/4	LSB-1500B-5	5	1	11 5/8	9 1/4	46	12
1500	3/4	LSB-1500B-10	10	1	11 5/8	9 1/4	46	14
1500	3/4	LSB-1500B-15	15	1	11 5/8	9 1/4	46	16
1500	3/4	LSB-1500B-20	20	1	11 5/8	9 1/4	46	18
3000	1 1/2	LSB-3000B-5	5	1	13	14 9/16	59	21
3000	1 1/2	LSB-3000B-10	10	1	13	14 9/16	59	24
3000	1 1/2	LSB-3000B-15	15	1	13	14 9/16	59	27
3000	1 1/2	LSB-3000B-20	20	1	13	14 9/16	59	30
6000	3	LSB-6000B-5	5	1	16 5/16	14 9/16	75	35
6000	3	LSB-6000B-10	10	1	16 5/16	14 9/16	75	40
6000	3	LSB-6000B-15	15	1	16 5/16	14 9/16	75	45
6000	3	LSB-6000B-20	20	1	16 5/16	14 9/16	75	50
12000	6	LSB-12000B-5	5	2	22 3/4	14 9/16	76	67
12000	6	LSB-12000B-10	10	2	22 3/4	14 9/16	76	77
12000	6	LSB-12000B-15	15	2	22 3/4	14 9/16	76	88
12000	6	LSB-12000B-20	20	2	22 3/4	14 9/16	76	99

COFFING®
HOISTS

* Standard lifts shown. Other lifts available - Consult factory

Note: For complete dimensional data, refer to Coffing Dimensional Databook

RATCHET LEVER HOISTS



RATCHET LEVER HOISTS

MODELS

TB-602
TB-603

**HANDY
MINI-HOIST -
EASY TOOL BOX
STORAGE**

TB-602 & TB-603 Ratchet Lever Hoists

Coffing TB-602 & TB-603 Models - The most compact ratchet lever hoists in the market. The TB-602 and TB-603 toolbox hoists perform just like the larger hoists, but are small enough to fit in a hardhat.

CAPACITIES & LIFT - Rated loads of 550 lb. (TB-602) and 1100 lb. (TB-603). 5 ft. and 10 ft. lifts available.

LOAD CHAIN & LOAD BRAKE - Hardend link-type steel load chain and Weston-type load brake are standard

GRIP & HOOKS - Rubber hand grip for better comfort and security. Forged upper and lower hooks with latches standard.

IMPACT RESISTANT - All-steel frame, gear case and cover.

PORTABILITY - Lightweight design for ease of portability. Use in confined conditions with one-hand operation.

EASY FREE CHAINING - State-of-the-art free wheeling mechanism allows quick and easy take-up and positioning of slack chain.

LIFETIME WARRANTY



● SPECIFICATIONS ●

TB-602 / TB-603 Ratchet Lever Hoists

Capacity		Model Number	Number of Chainfalls	Chain Dimensions d x t (in.)	Handle Length (in.)	Minimum Distance Between Hooks (in.)	Lift w/ One Full Lever Turn (in.)	Handle Pull @ W.L.L. (lb.)	Net Weight w/ Standard Lift (lb.)
(lb.)	(kg)								
550	250	TB-602	1	.16 x .47	6.300	9.45	3.15	56	6
1100	500	TB-603	1	.16 x .47	6.375	11.125	1.57	78	7

Note: For complete dimensional data, refer to Coffing Dimensional Databook

RATCHET LEVER HOISTS

ALUMINUM CONSTRUCTION – LOW HANDLE EFFORT

MODEL
PA



PA Model Ratchet Lever Hoist

COFFING PA Model - Aluminum ratchet lever hoists provide high quality and durability. The PA's extremely low handle effort and 360° rotating handle make it easy to operate, and the one-handed free chaining mechanism provides easy rigging. The PA is ideal for construction and commercial applications.

CAPACITIES & LIFT - Rated loads of 3/4, 1, 1 1/2, and 3 Tons, with 5, 10, 15, and 20 foot standard lifts.

RUGGED AND LIGHTWEIGHT - Unit and handle made from high strength ductile aluminum alloy. Compact design increases portability and rigging efficiency.

EASY TO USE - Double reduction gearing and short handle provide lowest handle effort in the Coffing line.

360° ROTATING HANDLE - Provides versatile rigging options when used in confined spaces.

EASY FREE CHAINING - State-of-the-art free wheeling mechanism allows quick and easy one-handed take-up and positioning of slack chain.

POSITIVE LOAD CONTROL - Enclosed self-adjusting screw-and-disc type load brake stays clean and dry — eliminating drift and backlash for safe, sure holding. Screw-and-disc brake lowering allows “micro-inching” load positioning.

LOW MAINTENANCE - Hardened steel load chain provides high strength and resists wear. Alloy steel spur gearing is heat-treated for long life and is lifetime lubricated.

LIFETIME WARRANTY



3/4 - 3 Ton

● SPECIFICATIONS ●

PA Model Ratchet Lever Hoists

Capacity		Model Number	Lift (ft.)	Strands of Load Chain	Minimum Dist. Between Hooks (in.)	Handle Length (in.)	Average Handle Effort (lb.)	Net Weight (lb.)
(lb.)	(Ton)							
1500	3/4	PA-1500	5	1	12	12	37	15
1500	3/4	PA-1510	10	1	12	12	37	17
1500	3/4	PA-1515	15	1	12	12	37	19
1500	3/4	PA-1520	20	1	12	12	37	21
2000	1	PA-2000	5	1	13	12	49	15
2000	1	PA-2010	10	1	13	12	49	17
2000	1	PA-2015	15	1	13	12	49	19
2000	1	PA-2020	20	1	13	12	49	21
3000	1 1/2	PA-3000	5	1	14 1/2	12	41	25
3000	1 1/2	PA-3010	10	1	14 1/2	12	41	29
3000	1 1/2	PA-3015	15	1	14 1/2	12	41	33
3000	1 1/2	PA-3020	20	1	14 1/2	12	41	37
6000	3	PA-6000	5	2	17 1/2	16	61	41
6000	3	PA-6010	10	2	17 1/2	16	61	48
6000	3	PA-6015	15	2	17 1/2	16	61	55
6000	3	PA-6020	20	2	17 1/2	16	61	62

Note: For complete dimensional data, refer to Coffing Dimensional Databook

COFFING®
HOISTS



MODEL

MA / MAL

**FIVE SEALS
PROTECT
INTERNAL
COMPONENTS**

MA & MAL Ratchet Lever Hoists



3/4 - 6 Ton

Made in USA

COFFING MA and MAL Models - Survive the toughest environments to provide safe, secure load control. Five seals (exclusive to the MA and MAL) increase the life of the hoist by protecting the gears and the brake mechanism from contamination by oil, grease, dirt, water, and other environmental hazards (see page 54). The MA and MAL are ideal for construction, industrial, and maintenance applications which require a brake for precise positioning or to disengage the tension on the load.

CAPACITIES & LIFT - Rated loads from 3/4 to 6 Tons, with 5-foot standard lift. Other lifts available.

RUGGED - Unit and handle made from high strength ductile aluminum alloy for corrosion resistance and portability.

FREE CHAINING MECHANISM - Allows quick and easy one-handed take-up and positioning of slack chain. Will not accidentally free chain when under load.

FIVE SEALS - Keep the brake mechanism clean and dry, so braking performance remains consistent even under severe exposure conditions.

LOAD LIMITER (MAL Models) - See page 54.

PRECISE LOAD POSITIONING - Screw and disc brake lowering allows "micro-inching" for load spotting within fractions of an inch.

HANDLE STOPS - Keep handle from spinning in case operator's hand accidentally slips off the handle.

TOP SLING MODELS - Allow secure fastening around posts, beams, and other anchor points for easy rigging. MAR model has 30" sling with grab hook.

OPTIONS - Bullard hooks, bronze hooks, zinc-plated hooks, and zinc-plated chain - consult factory.

LIFETIME WARRANTY

● SPECIFICATIONS ●

MA & MAL Ratchet Lever Hoists

Capacity		Model Number *	Strands of Load Chain	Minimum Dist. Between Hooks (in.)	Handle Length (in.)	Minimum Lifting Increment (in.) †	Average Handle Effort (lb.)	Net Weight (lb.) ††
(lb.)	(Ton)							
1500	3/4	MA(L)-15	1	12 7/16	20 1/2	0.451	59	12 1/4
2000	1	MA(L)-20	1	12 7/16	20 1/2	0.451	79	12 1/4
3000	1 1/2	MA(L)-15-2	2	17 1/4	20 1/2	0.226	60	18
3000	1 1/2	MA(L)-30	1	13 3/4	20 1/2	0.256	82	23
4000	2	MA(L)-40	1	13 3/4	20 1/2	0.256	109	23
6000	3	MA(L)-30-2	2	17 1/4	20 1/2	0.128	93	35
9000	4 1/2	MA(L)-30-3	3	22	20 1/2	0.085	96	53
12000	6	MA(L)-30-4	4	22	20 1/2	0.064	97	63

* Designate MAL model number for load limiter option. Designate MAR for 30" top sling with grab hook. Longer slings available.

† Minimum increment in lowering position is infinitesimal

†† Add approx. 2 lbs. for MAL version

Note: For complete dimensional data, refer to Coffing Dimensional Databook



EASY OPERATOR — RATCHET & PAWL DESIGN

MODEL RA

RA Model Ratchet Lever Hoist

COFFING RA Model - Aluminum ratchet lever hoists utilize a ratchet and pawl design. The RA is ideal for transmission and distribution utility applications where a disc brake mechanism is not desirable.

CAPACITIES & LIFT - Rated loads from 3/4 to 6 Tons, with 5-foot standard lift. Other lifts available.

RUGGED - Unit and handle made from high strength ductile aluminum alloy for corrosion resistance and portability.

FREE CHAINING MECHANISM - Allows quick and easy one-handed take-up and positioning of slack chain. Will not accidentally free chain when under load.

RATCHET AND PAWL DESIGN - Provides easy operation and freedom from maintenance. One pawl is always engaged with the ratchet during lifting and lowering operations, so handle will not ratchet when lowering a load if handle is unintentionally released.

OPEN BODY CONSTRUCTION - Permits easy inspection of suspension hook assembly.

HANDLE STOPS - Keep handle from spinning in case operator's hand accidentally slips off the handle.

MULTIPLE RIGGING OPTIONS - Hoist can lift, pull, or bind. Can be operated from either side and will work in any position with equal efficiency.

TOP SLING MODELS - Allow secure fastening around posts, beams, and other anchor points for easy rigging. RAR model has 30" sling with grab hook. RADO model has a 15" sling with a standard hook.

OPTIONS - Bullard hooks, bronze hooks, zinc-plated hooks, and zinc-plated chain - *consult factory*.

LIFETIME WARRANTY



3/4 - 6 Ton
Made in USA

● SPECIFICATIONS ●

RA Model Ratchet Lever Hoists

Capacity		Model Number	Strands of Load Chain	Minimum Dist. Between Hooks (in.)	Handle Length (in.)	Minimum Increment (in.) †	Average Handle Effort (lb.)	Net Weight (lb.)
(lb.)	(Ton)							
1500	3/4	RA-15	1	12 7/16	20 1/2	0.451	59	12 1/4
2000	1	RA-20	1	12 7/16	20 1/2	0.451	79	12 1/4
3000	1 1/2	RA-15-2	2	17 1/4	20 1/2	0.226	60	18
3000	1 1/2	RA-30	1	13 3/4	20 1/2	0.256	82	23
4000	2	RA-40	1	13 3/4	20 1/2	0.256	109	23
6000	3	RA-30-2	2	17 1/4	20 1/2	0.128	93	35
9000	4 1/2	RA-30-3	3	22	20 1/2	0.085	96	53
12000	6	RA-30-4	4	22	20 1/2	0.064	97	63

* Designate RAR model for 30" top sling with grab hook, or RADO model for 15" top sling with standard hook. Longer sling lengths available.

† Minimum increment in lifting or lowering position.

Note: For complete dimensional data, refer to Coffing Dimensional Databook





G Series Ratchet Lever Hoist



Snap Hook

3/4 - 15 Ton

Made in USA

COFFING G Series Model - Malleable iron roller chain ratchet lever hoists are efficient and durable. Roller chain can be spliced to create longer lifts and can handle higher capacities than coil chain. G Series hoists are ideal for utility transmission and distribution work.

CAPACITIES & LIFT - Rated loads from 3/4 to 15 Tons. For standard lift, see chart below. Other lifts available.

RUGGED - Unit and handle made from malleable iron. Riveted construction makes the unit tamper-resistant.

FREE CHAINING - Free chaining mechanism allows quick and easy take-up and positioning of slack chain. Hoist will not free chain when under load.

HANDLE STOPS - Prevent handle from spinning if it is accidentally released by the operator.

SINGLE OR DOUBLE LOCKING PAWL DESIGN - See page 54.

MULTIPLE RIGGING OPTIONS - Hoist can lift, pull, or bind. Can be operated from either side and will work in any position with equal efficiency.

SNAP HOOK AND LINK - Allows operator to convert unit to next smaller capacity to give longer lift and faster operation. Snap hook acts as an end stop and will not pass through chain sprocket.

OPTIONS - Bullard hooks, bronze hooks, and zinc-plated hooks - consult factory.

LIFETIME WARRANTY

● SPECIFICATIONS ●

G Series Ratchet Lever Hoists

Capacity		Model Number †	Standard Lift (in.)	Strands of Load Chain	Minimum Dist. Between Hooks (in.)	Handle Length (in.)	Minimum Increment (in.) †	Average Handle Effort (lb.)	Net Weight (lb.)
(lb.)	(Ton)								
1500	3/4	AG/AGI	56 1/2	1	13	18 3/4	.624/.313	56	14
3000	1 1/2	ATG/ATGI	57	2	15	18 3/4	.313/.156	60	17
3000	1 1/2	FG/FGI	56 1/2	1	16	27 5/8	1.0/.5	116	25
6000	3	FTG/FTGI	57	2	17 5/8	27 5/8	.50/.25	120	34
9000	4 1/2	ZG-4 1/2	53	3	25	33 5/8	0.3333	124	49
12000	6	ZG-6	53	4	25	33 5/8	0.25	124	59
18000	9	WG-9	60	5	30	33 5/8	0.2	124	120
22000	11	WG-11	60	6	30	33 5/8	0.167	124	130
26000	13	WG-13	60	7	30	33 5/8	0.143	124	140
30000	15	WG-15	60	8	30	33 5/8	0.125	124	150

† First designation is single pawl model and second "I" designation is double pawl model

Note: For complete dimensional data, refer to Coffing Dimensional Databook



**SAFETY,
DURABILITY**
Plus
VERSATILITY

CABLE
MODELS



CABLE Ratchet Lever Hoist

COFFING Cable Models - Provide high quality and durability, with a wide variety of rigging options. Coffing Cable Hoists are designed for safety and have many features that provide easy operation. Ideal for construction and commercial applications.

HANDLE DESIGN / OVERLOAD PROTECTION - Handle bends to warn of hazardous condition and prevent dangerous overload.

HOOKS - 360° swiveling hooks equipped with latches for positive load engagement.

POSITIVE LOAD HOLDING - Double interlocking pawl mechanism assures one pawl is engaged at all times.

RELIABLE OPERATION - Meets or exceeds minimum 4:1 design factor and all requirements of ASME/ANSI Standard B-30.21. All units tested at 125% of rated load.

LIGHTWEIGHT AND RUGGED - Special cast aluminum and zinc alloy housings.

HEAVY-DUTY CABLE - Utilizes preformed and galvanized, extra flexible aircraft cable.

CORROSION RESISTANT - All stainless steel springs and shafts.

REDUCED WEAR - All rotating shafts are mounted on bronze bushings.

EASY LOAD POSITIONING - Utilizes a double pawl system with multiple pawl stops for precise load adjustment.

FAST CABLE TAKE-UP - Winding wheel provided for quick take-up or positioning of cable.

OPEN CONSTRUCTION - Allows for easy cleaning and inspection.

STAINLESS STEEL CABLE AVAILABLE - Suitable for marine environments.

LIFETIME WARRANTY



1/4 - 2 Ton

Made in USA

● SPECIFICATIONS ●

Cable Ratchet Lever Hoists

Model Number	Single Line				Double Line				Cable Diameter (in.)	Ship Weight (lb.)
	Capacity		Lift (ft.) *	Hook to Hook Min. (in.)	Capacity		Lift (ft.) *	Hook to Hook Min. (in.)		
	(lb.)	(Ton)			(lb.)	(Ton)				
C105SB	1000	1/2	40	20	----	----	----	----	3/16	12 1/2
C115SB	1000	1/2	23	20	----	----	----	----	3/16	11
C115DB	1000	1/2	23	20	2000	1	11 1/2	27	3/16	14
C505NB	1500	3/4	17	20	----	----	----	----	1/4	11 1/2
C202WNB	1500	3/4	17	20	3000	1 1/2	9	27	1/4	14
C434WNB	1500	3/4	22	20	3000	1 1/2	11	27	1/4	15 1/4
C430CDPB	1500	3/4	22	20	3000	1 1/2	11 1/4	27	1/4	17
C404WNB	2000	1	17	20	4000	2	8 1/2	27	9/32	16 1/2

* Lift is measured according to ANSI standards, which require two wraps of cable on the drum at all times.

Note: For complete dimensional data, refer to Coffing Dimensional Databook





MODEL
A / AD

MODEL
GT



3/4 - 1 1/2 Ton

Made in USA

A & AD Ratchet Lever Load Binders

COFFING A and AD Models - Roller chain load binders provide quality and durability. Unlike over-center binders, the ratchet and pawl design protects the operator by providing incremental take-up for proper tensioning and securing of the load.

CAPACITIES & LIFT - Rated loads from 3/4 to 1 1/2 Tons. For standard lift, see chart below.

CONVERTIBLE - Double-chain model converts to single-chain.

LIFETIME WARRANTY

● SPECIFICATIONS ●

A & AD Ratchet Lever Load Binders

Load Limits		Ultimate Strength (lb.)	Model	Std. Reach (in.)	Strands of Load Chain	Minimum Dist. Between Hooks (in.)	Handle Length (in.)	Take-Up Increments (in.)	Net Weight (lb.)
Working (lb.)	Proof (Ton)								
1500	3000	7500	A	19 1/2	1	15 1/2	19 1/4	5/8	11 1/2
3000	6000	15000	AD	20	2	16 3/4	19 1/4	5/16	14 1/2

COFFING[®]
HOISTS

RATCHET LOAD BINDERS / PULLERS



GT-1300-32

GT-2000-65

GT-3500-32

GT Model Wire Rope Lever Tool

COFFING GT Models - Designed for heavy-duty pulling, rigging, dragging, stretching and lifting applications. Its versatility and ability makes it perfect for use in the construction and transportation industries, as well as hundreds of other industrial applications. Coffing GT models are lightweight, compact and built tough for long life and trouble-free service.

CAPACITIES - Rated loads from 1 to 3 Tons. 32 ft. of wire rope on 1 and 3 Ton models / 65 ft. of wire rope on 2 Ton models

SMOOTH OPERATION - Large surface area of dual clamping jaws provide an evenly distributed grip for smooth operation and low wear.

LIFETIME WARRANTY

● SPECIFICATIONS ●

GT Wire Rope Lever Tool

Model	Rated Capacity (Tons)	Product Code	Standard Wire Rope Length (ft.)	Wire Rope Diameter (in.)	Lever Length Extended (in.)	Lever Length Retracted (in.)	Rope Advance † (in.)	Overall Dimensions (in.)	Net Weight * (lb.)	Net Weight ** (lb.)
GT-1300-32	1	0013	32	5/16	29.1	21.3	1.30	19.7 x 9.1 x 4.0	35	18
GT-2000-65	2	0020	65	7/16	29.1	21.3	1.45	24.8 x 13.0 x 5.9	79	40
GT-3500-32	3	0035	32	5/8	29.1	21.3	0.78	28.6 x 12.8 x 7.0	94	66

† Per full stroke at rated load

* Wire rope included

** Less Wire Rope

CLASS UP WITH COFFING®

COFFING® HOISTS

*Service • Maintenance • Sales
Training for Coffing Products*

SERVICE SCHOOL

The Coffing Service School provides hands-on, factory training for technical, manufacturing and sales personnel. Held at Coffing's Wadesboro, NC manufacturing facility, this specialized instruction program places students close to the products and knowledgeable personnel. An effort is made to keep the class size to a minimum, ensuring maximum hands-on experience, personal attention and time for thorough understanding of class materials. The Coffing Service School is designed to cover the following topics:



- Troubleshooting
- Inspection Techniques and Procedures
- Preventive Maintenance
- Standard Magnetic Contactor Control
- Product Identification
- Manufacturing & Testing
- Introductions to Key Personnel

COFFING COLLEGE - COFFING SAFETY TRAINING PROGRAMS

Coffing College is designed to orient students to the Coffing organization, its product line and product sales features. Also included in this instruction is the Little Mule line of products. Held at the Wadesboro, NC manufacturing plant, attendees of Coffing College enjoy the casual and informative experience.

Coffing Safety Training Programs are offered by Coffing Hoists at your location, or an off-site property in your area. Conducted by Coffing's District Sales Managers, these programs cover many aspects in proper use of manual and powered hoists, with emphasis on maintenance and safe operating procedures.

Contact your local Coffing District Sales Manager for details, or visit www.coffinghoists.com

NEW DIMENSIONS

COFFING®
HOISTS

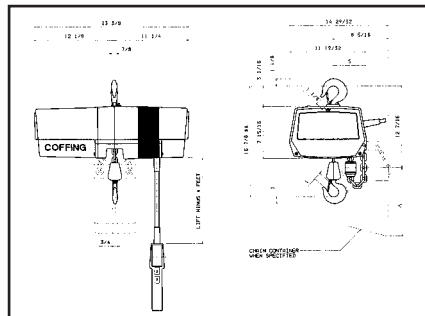

The Coffing Dimensional Databook is the companion publication to the Coffing Catalog. It features the latest dimensional drawings and related technical information.

*To obtain a copy, log on
www.coffinghoists.com*



ORDERING INFORMATION

SPECIFYING ELECTRIC CHAIN MODEL NUMBERS

EC - 05 16 - 1 - 10

MODELS

CAPACITY
(lb.)

LIFT
SPEED

VOLTAGE

LIFT

MODEL	DESCRIPTION	CAPACITY (lb.)	LIFT SPEED (FPM)	VOLTAGE	LIFT (Ft.)
EC	Electric Chain, Hook Mounted	02 250	04 4 FPM	1 115/230 V (Single-Speed)	10 10 Ft.
ELC	Electric Chain, Hook Mounted	05 500	05 5 FPM	2 230 V (Two-Speed)	15 15 Ft.
ECT	Electric Chain, w/ Plain Trolley	10 1000	06 6 FPM	3 230/460 V (Single-Speed)	20 20 Ft.
ELCET	Electric Chain, w/ Plain Trolley	20 2000	08 8 FPM	4 460 V (Two-Speed)	25 25 Ft.
ECGT	Electric Chain, w/ Geared Trolley	40 4000	09 9 FPM	5 575 V (Single-Speed)	30 30 Ft.
ECMT	Electric Chain, w/ Motorized Trolley	60 6000	10 10 FPM	6 575 V (Two-Speed)	35 35 Ft.
ELCMT	Electric Chain, w/ Motorized Trolley	80 8000	12 12 FPM	7 208 V (Single-Speed)	40 40 Ft.
ED	Extended Duty, Lug Mounted	100 10000	16 16 FPM	8 208 V (Two-Speed)	45 45 Ft.
EDT	Extended Duty, w/ Plain Trolley		24 24 FPM	<i>Consult Factory for Special Voltages</i>	Etc.
EDGT	Extended Duty w/ Geared Trolley		32 32 FPM		
EDMT	Extended Duty w/ Motorized Trolley		64 64 FPM		



ORDERING INFORMATION



COFFING
HOISTS

I-BEAM SPECIFICATIONS

The following table shows the standard sizes, flange widths and weights for both American Standard and Wide Flange I-beams. I-beams designated with an asterisk (*) denote New Series specifications which conform ASTM A6 standards, effective September 1, 1978.

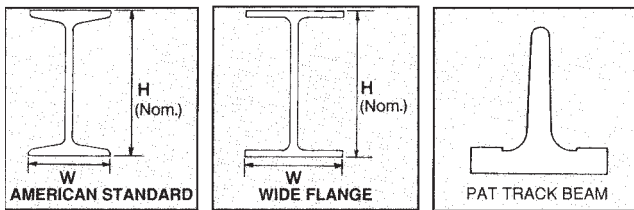

Order Checklist

When ordering a Coffing® Hoist Trolley, be sure to include:

Total Rated Load (Lb.)	
Required Trolley Speed (Ft./Min.)†	
Motor Voltage†	
I-Beam Height (In.)	
I-Beam Flange Width (In.)	
I-Beam Weight Per Foot (Lb.)	
Trolley Model Number	
Hoist Model Number	

†MT series trolleys only.

American Standard			Wide Flange								
H (In.)	Weight Per Foot (Lb.)	W (In.)	H (In.)	Weight Per Foot (Lb.)	W (In.)	H (In.)	Weight Per Foot (Lb.)	W (In.)	H (In.)	Weight Per Foot (Lb.)	W (In.)
4	7.7	2.663	6	8.5	3.940	10	77	10.190	16*	50	7.070
4	9.5	2.796	6*	9	4	10*	77	10.190	16*	57	7.120
5	10	3.004	6*	12	4	10*	88	10.265	16	58	8.464
5	14.75	3.284	6*	12	4	10	89	10.275	16*	67	10.235
6	12.5	3.332	6	16	4.030	10	100	10.340	16*	77	10.295
6	17.25	3.565	6*	16	4.030	10*	100	10.340	16*	89	10.365
7	15.3	3.662	6*	15	5.990	10	112	10.415	16*	100	10.425
7	20	3.860	6	15.5	5.995	10*	112	10.415	16	88	11.502
8	18.4	4.001	6	20	6.020	12	14	3.968	16	96	11.5
8	23	4.171	6*	20	6.018	12*	14	3.970	18	35	6
10	25.4	4.661	6	25	6.080	12*	16	3.990	18*	35	6
10	35	4.944	6*	25	6.080	12	16.5	4	18	40	6.015
12	31.8	5	8	10	3.940	12	19	4.005	18*	40	6.015
12	35	5.078	8*	10	3.940	12*	19	4.007	18*	46	6.060
12	40.8	5.252	8	13	4	12	22	4.030	18	45	7.477
12	50	5.477	8*	13	4	12*	22	4.030	18	50	7.5
15	42.9	5.501	8	15	4.015	12*	22	6.490	18*	50	7.5
15	50	5.640	8*	15	4.015	12	27	6.497	18	55	7.532
18	54.7	6.001	8	17	5.250	12*	30	6.520	18*	55	7.530
18	70	6.251	8*	18	5.250	12	31	6.525	18	60	7.558
20	65.4	6.25	8	20	5.268	12*	35	6.560	18*	60	7.555
20	75	6.385	8*	21	5.270	12	36	6.565	18*	71	7.635
20	86	7.060	8	24	6.495	12	40	8	18	64	8.715
20	96	7.200	8*	24	6.5	12*	40	8.005	18	70	8.75
24	79.9	7.001	8	28	6.535	12	45	8.042	18	77	8.787
24	90	7.125	8*	28	6.535	12*	45	8.045	18*	76	11.035
24	100	7.245	8	31	7.995	12	50	8.077	18*	86	11.090
24	105.9	7.875	8*	31	7.995	12*	50	8.080	18*	97	11.145
24	121	8.050	8	35	8.020	12	53	10	18*	106	11.200
			8*	35	8.020	12*	53	9.995	18*	119	11.265
			8	40	8.070	12	58	10.014	18	96	11.75
			8*	40	8.070	12*	58	10.010	21	44	6.5
			8	48	8.110	14	22	5	21*	44	6.5
			8*	48	8.110	14*	22	5	21*	50	6.530
			8	58	8.220	14	26	5.025	21*	57	6.555
			8*	58	8.220	14*	26	5.025	21	55	8.215
			8	67	8.280	14	30	6.730	21	62	8.240
			8*	67	8.280	14*	30	6.730	21*	62	8.240
			10	11.5	3.950	14	34	6.75	21	68	8.270
			10*	12	3.960	14*	34	6.745	21*	68	8.270
			10	15	4	14	38	6.770	21	73	8.295
			10*	15	4	14*	38	6.770	21*	73	8.295
			10	17	4.010	14	43	8	21*	83	8.355
			10*	17	4.010	14*	43	7.995	21*	93	8.420
			10	19	4.020	14	48	8.031	21	82	8.962
			10*	19	4.020	14*	48	8.030	24	55	7.005
			10	21	5.75	14	53	8.062	24*	55	7.005
			10*	22	5.75	14*	53	8.060	24*	62	7.040
			10	25	5.762	14	61	10	24	68	8.961
			10*	26	5.770	14*	61	9.995	24*	68	8.965
			10	29	5.799	14	68	10.035	24	76	8.985
			10*	30	5.810	14	68	10.035	24*	76	8.990
			10	33	7.960	14	74	10.072	24	84	9.015
			10*	33	7.960	14*	74	10.070	24*	84	9.020
			10	39	7.985	14	78	12	24	94	9.065
			10*	39	7.985	14	87	14.500	24*	94	9.065
			10	45	8.020	14*	82	10.130			
			10*	45	8.020	16	26	5.5			
			10	49	10	16	31	5.525			
			10*	49	10	16*	31	5.525			
			10	54	10.030	16	36	6.992			
			10*	54	10.030	16*	36	6.985			
			10	60	10.080	16	40	7			
			10*	60	10.080	16*	40	6.995			
			10	66	10.117	16	45	7.039			
			10*	68	10.130	16*	45	7.035			
			10	72	10.170	16	50	7.073			

ORDERING INFORMATION

*Coffing Hoists Offers a Complete Line
of Material Handling Equipment*



LODERAIL® - Light Rail Systems

LODERAIL® is a true, freestanding light rail system, sold as a complete package - even the floor bolts are included. With capacities up to 2 tons, bridge spans up to 34 feet, and unlimited runway length, LodeRail is widely used in workstation or material transport systems. Modular design provides efficient assembly or relocation, unique mitered corners provide added strength, and smooth rolling trolleys have sealed bearings with lifetime lubrication. Featuring a productivity ratio of 100:1, an operator can safely start a 500 lb. load moving with only 5 lbs. of force. Another outstanding benefit of a LodeRail system is its Seismic Zone 4 rating. Overhead mounted and powered systems are available.



JIB CRANES - Abell-Howe®

Manufacturing freestanding, wall bracket, and mast designs , ABELL-HOWE® jib cranes range from 500 - 20,000 lb. capacities, with spans up to 30 feet, and under boom heights from 8 to 30 feet. Larger capacities and special configurations are available. Freestanding jibs feature full 360° rotation, foundation or base plate mounting, and can be electrically powered (air rotation and hand gearing are also available). Wall mounted jibs provide up to 200° rotation and are available in tie rod or full cantilever designs. Anchored both at floor and overhead, mast jib cranes do not require extensive foundation support. A drop boom version can be used to clear overhead obstructions.



CRANE COMPONENTS

Featuring top running or underhung, single girder end trucks—crane components provide a wide range of options for material handling needs. Select end trucks as push-type, hand geared, or powered (electric or air) models. With capacities up to 5 tons, spans to 36 feet, the ability to fit standard I-beams, wide flange and patented track, these crane components can fit the requirements for most applications. Standard options of spark resistance, single or dual drive, multiple control panels, and festooning systems make these kits (minus the span beams) complete.



CADY® / CAMLOCKS - Specialized Attachments

In applying technology and manufacturing to heavy lifting applications, CADY provides a complete line of below-the-hook lifters. Cady products are designed to handle rolls, coils, crates, bundles, sheets, and pallets.

CAMLOCK PLATE CLAMPS are special devices commonly used below-the-hook to efficiently move sheets of material or beams. A wide variety of models are available to fit the particular material handling task.

High Performance Lifting

COFFING[®] HOISTS

The employees of Coffing Hoists pride themselves in offering a wide range of products to meet your lifting, pulling, and rigging needs. Years of engineering know-how, dedication to superior manufacturing, and valued customer input have led to the design and continuous refinement of each Coffing product.

When you buy a Coffing hoist, you get performance you can count on. We back every hoist with a lifetime warranty no one else can match. Our promise is that Coffing hoists will work longer and harder because we build them to last.

Experience, dedication, service, superior design and manufacturing - that's what High Performance Lifting is all about.





COFFING[®] HOISTS

2020 Country Club Road • P.O. Box 779
Wadesboro, N.C. 28170 USA

Phone: (800) 477-5003 • (704) 694-2156

Fax: (800) 374-6853 • (704) 694-6829

E-Mail: coffing@cmworks.com

www.coffinghoists.com

WARNING

Overloading and Improper Use Can Result In Injury

To Avoid Injury:

- Do not exceed working load limit, load rating, or capacity.
- Do not use to lift people or loads over people.
- Use only alloy chain for overhead lifting.
- Read and follow all instructions.